

Instructions—Parts List



SEVERE-DUTY, UHMWPE/PTFE OR PTFE PACKED Stainless Steel Pumps

308116M

Used to transfer or dispense low viscosity sealants and adhesives.

UHMWPE/PTFE PACKED PUMPS

Model No. 224342, Series A

10:1 Ratio President® Pump

1800 psi (13 MPa, 125 bar) Maximum Fluid Working Pressure

180 psi (1.3 MPa, 12.5 bar) Maximum Air Input Pressure

Model No. 224343, Series A

Model No. 261630, Series A

5:1 Ratio Monark® Pump

600 psi (4.2 MPa, 42 bar) Maximum Fluid Working Pressure

120 psi (0.8 MPa, 8.4 bar) Maximum Air Input Pressure

PTFE PACKED PUMPS

Model No. 247147, Series A

Model No. 902147, Series A

5:1 Ratio Monark® Pump

600 psi (4.2 MPa, 42 bar) Maximum Fluid Working Pressure

120 psi (0.8 MPa, 8.4 bar) Maximum Air Input Pressure

Severe-Duty Displacement Pumps have an abrasion-resistant displacement rod and cylinder. Refer to **Technical Data** on pages 22–23 for Wetted Parts information.



Important Safety Instructions

Read all warnings and instructions in this manual.
Save these instructions.

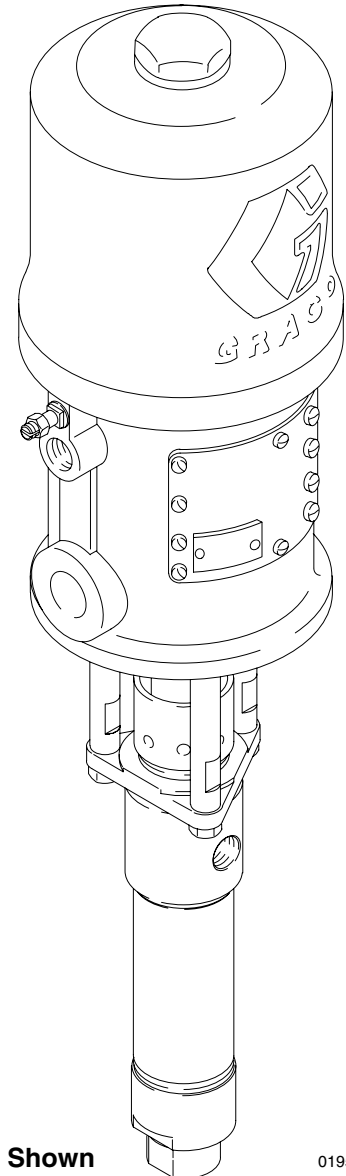

Model 224342 Shown

0195



PROVEN QUALITY. LEADING TECHNOLOGY.

Table of Contents

Warnings	2	Parts Drawings and Lists	15
Typical Installation	5	Model 224342 President Pump	15
Installation	6	Model 224343 and 261630 Monark Pumps	16
Operation/Maintenance	8	Model 902147 and 247147 Monark Pumps	17
Service	11	Model 224341 and 254999	
Troubleshooting Chart	11	Displacement Pumps	18
Disconnecting the Displacement Pump	12	Model 15G976 Displacement Pump	20
Reconnecting the Displacement Pump	12	Technical Data and Performance Charts	22
Displacement Pump Service	13	Dimensions	24
		Mounting Hole Layout	24
		Graco Standard Warranty	26
		Graco Information	26

Symbols

Warning Symbol



This symbol alerts you to the possibility of serious injury or death if you do not follow the instructions.

Caution Symbol



This symbol alerts you to the possibility of damage to or destruction of equipment if you do not follow the instructions.

⚠ WARNING



INSTRUCTIONS

EQUIPMENT MISUSE HAZARD

Equipment misuse can cause the equipment to rupture or malfunction and result in serious injury.

- This equipment is for professional use only.
- Read all instruction manuals, tags, and labels before operating the equipment.
- Use the equipment only for its intended purpose. If you are not sure, contact your Graco distributor.
- Do not alter or modify this equipment.
- Check equipment daily. Repair or replace worn or damaged parts immediately.
- Do not exceed the maximum working pressure of the lowest rated system component. Refer to the **Technical Data** on pages 22–23 for the maximum working pressure of this equipment.
- Use fluids and solvents which are compatible with the equipment wetted parts. Refer to the **Technical Data** section of all equipment manuals. Read the fluid and solvent manufacturer's warnings.
- Do not use hoses to pull equipment.
- Route hoses away from traffic areas, sharp edges, moving parts, and hot surfaces. Do not expose Graco hoses to temperatures above 82°C (180°F) or below –40°C (–40°F).
- Wear hearing protection when operating this equipment.
- Do not lift pressurized equipment.
- Comply with all applicable local, state, and national fire, electrical, and safety regulations.

! WARNING

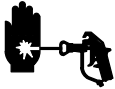

SKIN INJECTION HAZARD

Spray from the gun, leaks or ruptured components can inject fluid into your body and cause extremely serious injury, including the need for amputation. Fluid splashed in the eyes or on the skin can also cause serious injury.



- Fluid injected into the skin might look like just a cut, but it is a serious injury. **Get immediate surgical treatment.**
- Do not point the gun at anyone or at any part of the body.
- Do not put your hand or fingers over the spray tip.
- Do not stop or deflect leaks with your hand, body, glove or rag.
- Do not “blow back” fluid; this is not an air spray system.
- Always have the tip guard and the trigger guard on the gun when spraying.
- Check the gun diffuser operation weekly. Refer to the gun manual.
- Be sure the gun trigger safety operates before spraying.
- Lock the gun trigger safety when you stop spraying.
- Follow the **Pressure Relief Procedure** on page 8 if the spray tip clogs and before cleaning, checking or servicing the equipment.
- Tighten all fluid connections before operating the equipment.
- Check the hoses, tubes, and couplings daily. Replace worn or damaged parts immediately. Do not repair high pressure couplings; you must replace the entire hose.
- Fluid hoses must have spring guards on both ends, to help protect them from rupture caused by kinks or bends near the couplings.



MOVING PARTS HAZARD

Moving parts, such as the air motor piston, can pinch or amputate your fingers.

- Keep clear of all moving parts when starting or operating the pump.
- Before servicing the equipment, follow the **Pressure Relief Procedure** on page 8 to prevent the equipment from starting unexpectedly.

WARNING



FIRE AND EXPLOSION HAZARD

Improper grounding, poor ventilation, open flames or sparks can cause a hazardous condition and result in a fire or explosion and serious injury.

- Ground the equipment and the object being sprayed. Refer to **Grounding** on page 6.
- If there is any static sparking or you feel an electric shock while using this equipment, **stop spraying immediately**. Do not use the equipment until you identify and correct the problem.
- Provide fresh air ventilation to avoid the buildup of flammable fumes from solvents or the fluid being sprayed.
- Keep the spray area free of debris, including solvent, rags, and gasoline.
- Electrically disconnect all equipment in the spray area.
- Extinguish all open flames or pilot lights in the spray area.
- Do not smoke in the spray area.
- Do not turn on or off any light switch in the spray area while operating or if fumes are present.
- Do not operate a gasoline engine in the spray area.



TOXIC FLUID HAZARD

Hazardous fluid or toxic fumes can cause serious injury or death if splashed in the eyes or on the skin, inhaled, or swallowed.

- Know the specific hazards of the fluid you are using.
- Store hazardous fluid in an approved container. Dispose of hazardous fluid according to all local, state and national guidelines.
- Always wear protective eyewear, gloves, clothing and respirator as recommended by the fluid and solvent manufacturer.

Typical Installation

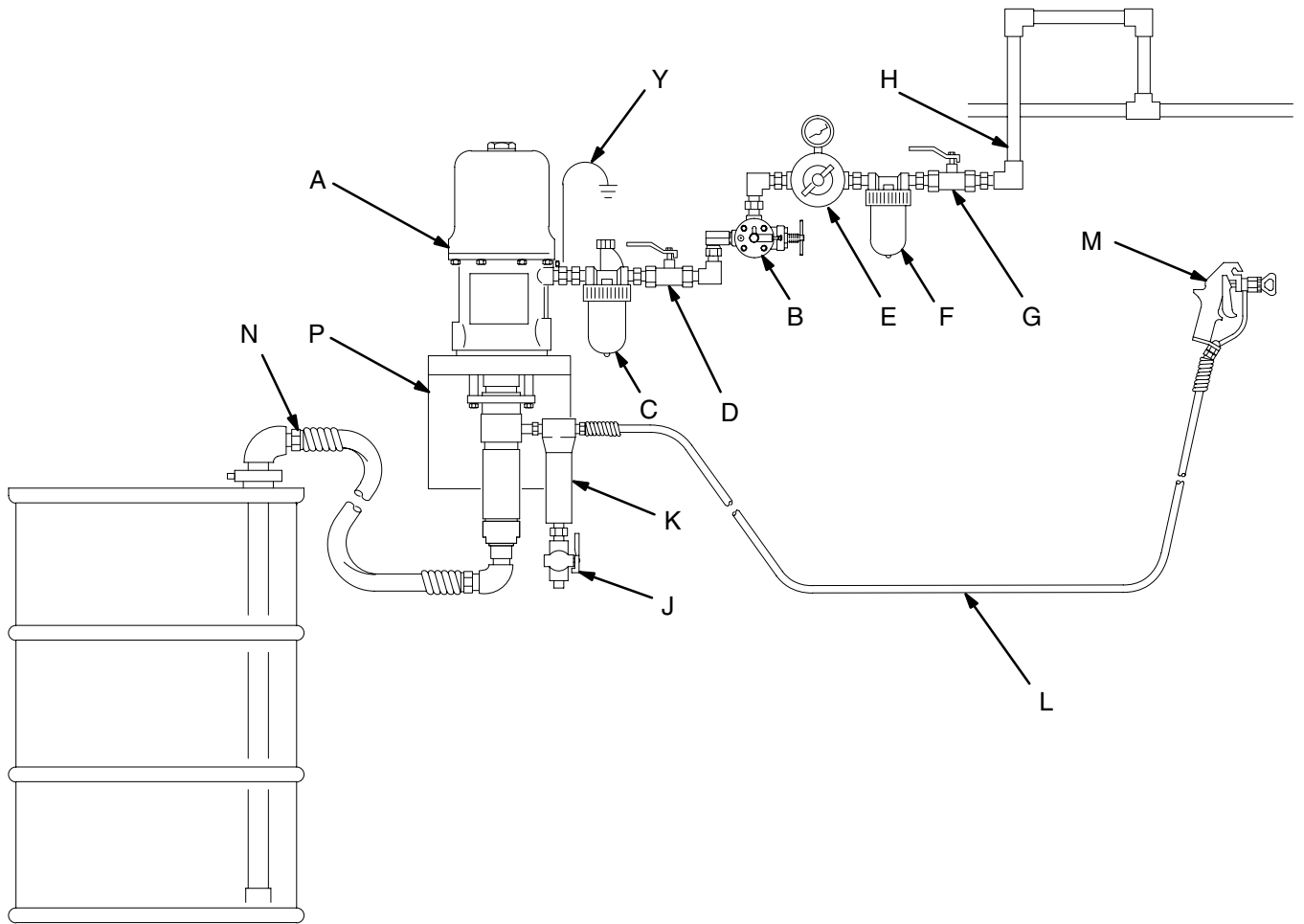

KEY

- A** Pump
- B** Pump Runaway Valve
- C** Air Line Lubricator
- D** Bleed-Type Master Air Valve (required, for pump)
- E** Pump Air Regulator
- F** Air Line Filter
- G** Bleed-Type Master Air Valve (for accessories)
- H** Air Supply Hose
- J** Fluid Drain Valve (required)
- K** Fluid Filter
- L** Fluid Supply Hose
- M** Spray Gun
- N** Fluid Suction Hose
- P** Wall Bracket
- Y** Ground Wire (required; see page 6 for installation instructions)

0774A

Fig. 1

Installation

General Information

NOTE: Reference numbers and letters in parentheses in the text refer to the callouts in the figures and the parts drawing.



NOTE: Always use Genuine Graco Parts and Accessories, available from your Graco distributor. If you supply your own accessories, be sure they are adequately sized and pressure rated for your system.

Fig. 1 is only a guide for selecting and installing system components and accessories. Contact your Graco distributor for assistance in designing a system to suit your particular needs.

Prepare the Operator

All persons who operate the equipment must be trained in the safe, efficient operation of all system components as well as the proper handling of all fluids. All operators must thoroughly read all instruction manuals, tags, and labels before operating the equipment.

Grounding

 WARNING	
	FIRE AND EXPLOSION HAZARD
	Before operating the pump, ground the system as explained below. Also read the section FIRE AND EXPLOSION HAZARD on page 4.

1. *Pump:* loosen the grounding lug locknut (W) and washer (X). Insert one end of a 12 ga (1.5 mm²) minimum ground wire (Y) into the slot in lug (Z) and tighten the locknut securely. See Fig 2. Connect the other end of the wire to a true earth ground. To order a ground wire and clamp, order Part No. 222011.

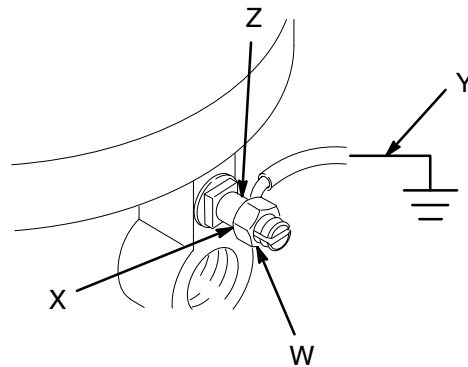

Fig. 2

0720

2. *Air and fluid hoses:* use only electrically conductive hoses.
3. *Air compressor:* follow manufacturer's recommendations.
4. *Spray gun:* ground through connection to a properly grounded fluid hose and pump.
5. *Fluid supply container:* follow your local code.
6. *Object being sprayed:* follow your local code.
7. *Solvent pails used when flushing:* follow your local code. Use only metal pails, which are conductive, placed on a grounded surface. Do not place the pail on a nonconductive surface, such as paper or cardboard, which interrupts the grounding continuity.
8. *To maintain grounding continuity when flushing or relieving pressure,* hold a metal part of the spray gun firmly to the side of a grounded *metal* pail, then trigger the gun.

Mounting the Pump

Mount the pump to suit the type of installation planned. The pump dimensions and mounting hole layout are shown on page 24.

If the pump is immersed, be sure the pump intake is 1/2 in. (13 mm) off the bottom of the fluid container.

If the pump is mounted on the wall or on a stand, connect a suction line to the pump's 3/4 in. npt(f) fluid inlet and place the other end of the line in the fluid container.

Installation

NOTE: Reference numbers and letters in parentheses in the text refer to the callouts in the figures and the parts drawing.

If you supply your own accessories, be sure they are adequately sized and pressure-rated to meet the system's requirements.

The **Typical Installation** shown on page 5 is only a guide for selecting and installing system components and accessories. Contact your Graco distributor for assistance in designing a system to suit your particular needs.

System Accessories

Refer to the **Typical Installation** on page 5.

WARNING

A bleed-type master air valve (D) and a fluid drain valve (J) are required in your system. These accessories help reduce the risk of serious bodily injury including fluid injection, splashing in the eyes or on the skin, and injury from moving parts if you are adjusting or repairing the pump.

The bleed-type master air valve relieves air trapped between this valve and the pump after the air is shut off. Trapped air can cause the pump to cycle unexpectedly. Locate the valve close to the pump.

The fluid drain valve assists in relieving fluid pressure in the displacement pump, hose, and gun. Triggering the gun to relieve pressure may not be sufficient.

Mounting Accessories

Mount the pump (A) to suit the type of installation planned. Refer to the **Dimensions** and **Mounting Hole Layout** page 24.

Air and Fluid Hoses

Be sure all air and fluid hoses are properly sized and pressure-rated for your system. Use only grounded air and fluid hoses. Fluid hoses must have spring guards on both ends.

Connect a grounded fluid hose (L) to the pump's fluid outlet.

Connect a fluid suction hose (N) to the pump's 3/4 npt(f) fluid intake.

Use a grounded 1/2 in. I.D. (minimum) air hose (H) to supply air to the pump.

Air Line Accessories

Install the following accessories in the order shown in the **Typical Installation**, using adapters as necessary:

An air line lubricator (C) provides automatic air motor lubrication.

A bleed-type master air valve (D) is required in your system to relieve air trapped between it and the air motor when the valve is closed (see the **Warning** at left). Be sure the bleed valve is easily accessible from the pump, and is located **downstream** from the air regulator.

A pump runaway valve (B) senses when the pump is running too fast and automatically shuts off the air to the motor. A pump which runs too fast can be seriously damaged.

An air regulator (E) controls pump speed and outlet pressure by adjusting the air pressure to the pump. Locate the regulator close to the pump, but **upstream** from the bleed-type master air valve.

An air line filter (F) removes harmful dirt and moisture from the compressed air supply.

A second bleed-type air valve (G) isolates the air line accessories for servicing. Locate upstream from all other air line accessories.

Fluid Line Accessories

Install the following accessories in the positions shown in the **Typical Installation**, using adapters as necessary:

A fluid drain valve (J) is required in your system to relieve fluid pressure in the hose and gun (see the **Warning** at left). Install the drain valve pointing down, but so the handle points up when opened.

A fluid filter (K) filters harmful particles from the fluid.

A spray gun (M) dispenses the fluid. The gun shown in the **Typical Installation** is an airless spray gun.

Operation/Maintenance

Pressure Relief Procedure

WARNING

PRESSURIZED EQUIPMENT HAZARD

The system pressure must be manually relieved to prevent the system from starting or spraying accidentally. To reduce the risk of an injury from accidental spray from the gun, splashing fluid, or moving parts, follow the **Pressure Relief Procedure** whenever you:

- are instructed to relieve the pressure,
- stop spraying,
- check or service any of the system equipment,
- or install or clean the spray tip.

1. Lock the spray gun safety latch.
2. Shut off the air supply to the pump.
3. Close the bleed-type master air valve (required in your system).
4. Unlock the gun safety latch.
5. Hold a metal part of the gun firmly to the side of a grounded metal pail, and trigger the gun to relieve pressure.
6. Lock the gun safety latch.
7. Open the drain valve (required in your system), having a container ready to catch the drainage.

8. Leave the drain valve open until you are ready to spray again.

*If you suspect that the spray tip or hose is completely clogged, or that pressure has not been fully relieved after following the steps above, **very slowly** loosen the tip guard retaining ring or hose end coupling and relieve pressure gradually, then loosen completely. Now clear the tip or hose.*

WARNING

Moving parts can pinch or amputate your fingers or other body parts. When air is supplied to the motor, the air motor piston (located behind the air motor plates) moves. See Fig. 3. Therefore, never operate the pump with the air motor plates removed.

Flush the Pump Before First Use

The pump is tested with lightweight motor oil, which is left in to protect the pump parts. If the fluid you are using may be contaminated by the oil, flush it out with a compatible solvent before using the pump. If the pump is being used to supply a circulating system, allow the solvent to circulate until the pump is thoroughly flushed.

WARNING

For your safety, read the warning section, **Fire or Explosion Hazard**, on page 4 before flushing, and follow all the recommendations given there.

Operation/Maintenance

Starting and Adjusting the Pump

See the **Typical Installation** on page 5. Be sure the air regulator (E) and bleed-type master air valve (D) are closed. **DO NOT INSTALL THE SPRAY TIP YET!**

Connect a suction hose (N) to the pump's fluid inlet. Hold a metal part of the spray gun (M) firmly to the side of a grounded metal pail and hold the trigger open. Then open the pump's bleed-type master air valve (D). Now slowly open the air regulator until the pump starts, about 40 psi (0.9 MPa, 2.8 bar).

Cycle the pump slowly until all the air is pushed out and the pump and hoses are fully primed. Release the spray gun trigger and lock the safety latch. The pump should stall against pressure when the trigger is released.

Follow the **Pressure Relief Procedure** on page 8, then install the spray tip in the gun.

With the pump and lines primed, and with adequate air pressure and volume supplied, the pump will start and stop as the spray gun is opened and closed. In a circulating system, the pump will run continuously and will speed up or slow down as supply demands until the air supply is shut off.

Use an adequately sized air regulator (E) to control the pump speed and the fluid pressure. Always use the lowest air pressure necessary to get the desired results. Higher pressures waste fluid and cause premature wear of the pump packings and spray tip.

WARNING

To reduce the risk of overpressurizing your system, which could result in component rupture and cause serious bodily injury, NEVER exceed the maximum incoming air pressure given on your pump or in the **Technical Data** on pages 22–23.

Keep the packing nut/wet-cup (2) filled with Graco Throat Seal Liquid (TSL) or compatible solvent, to help prolong the packing life. Adjust the packing nut weekly so it is just tight enough to prevent leakage; do not overtighten. See Fig. 3. Always follow the **Pressure Relief Procedure** on page 8 before adjusting the packing nut.

Never allow the pump to run dry of the fluid being pumped. A dry pump will quickly accelerate to a high speed, possibly damaging itself. A pump runaway valve (B), which shuts off the air supply to the pump if the pump accelerates beyond the pre-set speed, is available. See the **Typical Installation** on page 5. If your pump accelerates quickly, or is running too fast, stop it immediately and check the fluid supply. If the supply container is empty and air has been pumped into the lines, refill the container and prime the pump and the lines with fluid, or flush and leave it filled with a compatible solvent. Be sure to eliminate all air from the fluid system.

Shutdown and Care of the Pump

For overnight shutdown, follow the **Pressure Relief Procedure** on page 8. Always stop the pump at the bottom of the stroke to prevent the fluid from drying on the exposed displacement rod and damaging the throat packings.

Operation/Maintenance

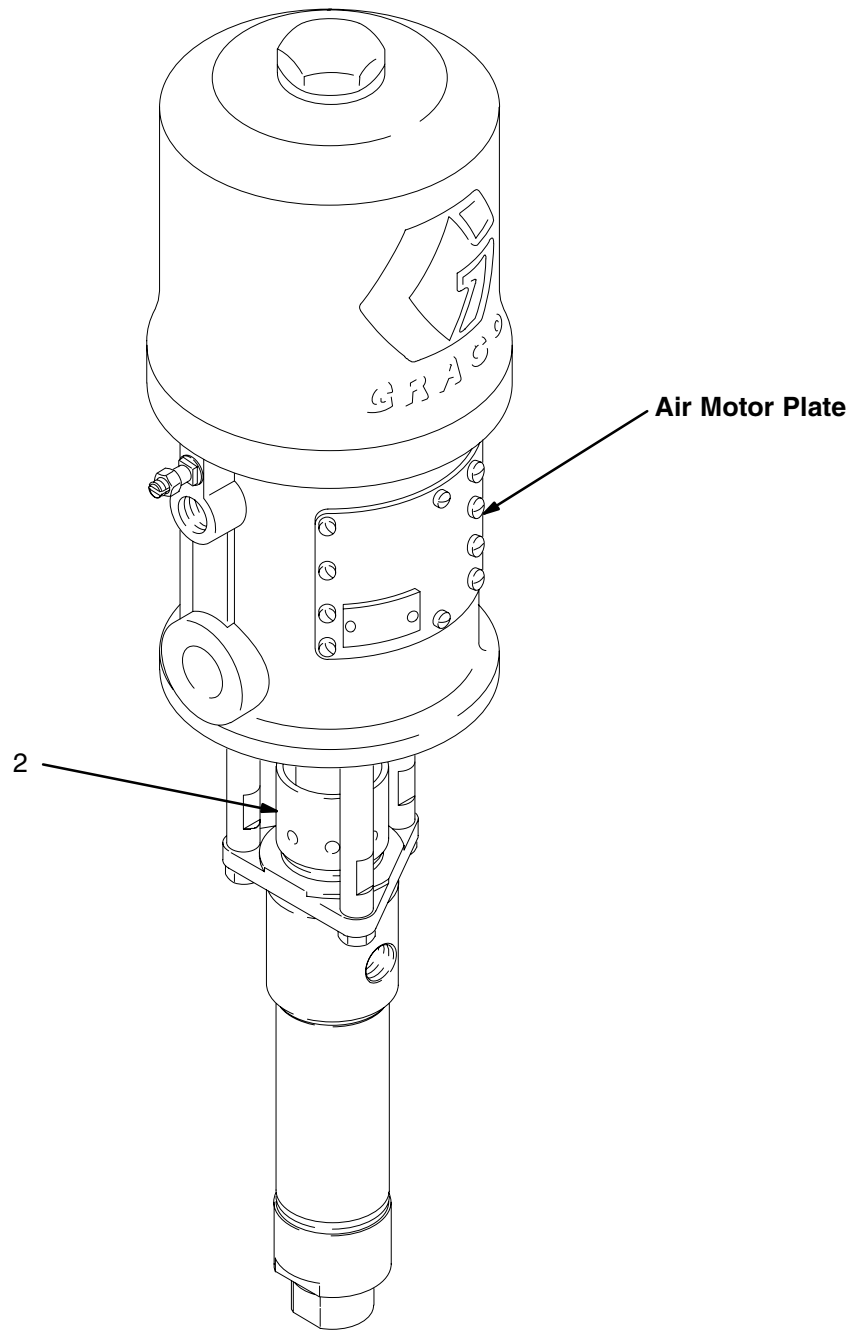

Fig. 3

0195

Troubleshooting

WARNING

To reduce the risk of serious injury whenever you are instructed to relieve pressure, always follow the **Pressure Relief Procedure** on page 8.

1. **Relieve the pressure.**
2. Check all possible problems and solutions before disassembling pump.

Problem	Cause	Solution
Pump fails to operate.	Restricted line or inadequate air supply.	Clear; increase air supply.
	Insufficient air pressure; closed or clogged air valves, etc.	Open; clean.
	Exhausted fluid supply.	Refill; purge all air from pump and fluid lines.
	Damaged air valving mechanism; stalling.	Service air motor (see 306982 or 307043).
	Dried fluid seizure of displacement rod (13).	Clean, check, or replace throat packings (5, 24); always stop pump at bottom of stroke and keep wet-cup filled with compatible solvent.
Pump operates but output is low on both strokes.	Restricted line or inadequate air supply.	Clear; increase air supply.
	Insufficient air pressure; closed or clogged air valves, etc.	Open; clean.
	Exhausted fluid supply.	Refill; purge all air from pump and fluid lines.
	Clogged fluid line, valves, etc.	Clear.*
	Packing nut (2) too tight.	Loosen (see page 9).
	Loose packing nut (2) or worn throat packings (5, 24).	Tighten packing nut (see page 9); replace throat packings.
Pump operates but output is low on downstroke.	Held open or worn intake valve.	Clear; service.
Pump operates but output is low on upstroke.	Held open or worn fluid piston valve or packings (20, 23).	Clear; service.
Erratic or accelerated operation.	Exhausted fluid supply.	Refill; purge all air from pump and fluid lines.
	Held open or worn intake valve.	Clear; service.
	Held open or worn fluid piston valve or packings (20, 23).	Clear; service.

* To determine if the fluid hose or gun is obstructed, follow the **Pressure Relief Procedure** on page 8. Disconnect the fluid hose and place a container at the pump fluid outlet to catch any fluid. Turn on the air just enough to start the pump (about 20–40 psi [0.1–0.3 MPa, 1.4–2.8 bar]). If the pump starts when the air is turned on, the obstruction is in the fluid hose or gun.

Service

Disconnecting the Displacement Pump

1. Flush the pump if possible. Stop the pump at the bottom of its stroke. Follow the **Pressure Relief Procedure** on page 8.
2. Disconnect the air and fluid hoses. Remove the pump from its mounting. Note the relative position of the pump's fluid outlet (R) to the air motor's air inlet (S).
3. Unscrew the tie rod locknuts (102) from the tie rods (103). Remove the cotter pin (111). Unscrew the displacement rod (13) from the air motor (108). Carefully pull the displacement pump (101) off the air motor (108). Inspect the o-ring (110). See Fig 4.
4. Refer to page 13 for displacement pump service. To service the air motor, refer to the separate air motor manual (306982 or 307043), supplied.

Reconnecting the Displacement Pump

1. Lubricate the o-ring (110) and check that it is in place on the displacement rod (13). Orient the pump's fluid outlet (R) to the air motor's air inlet (S) as was noted in step 2 under **Disconnecting the Displacement Pump**. Position the displacement pump (101) on the tie rods (103). See Fig 4.
2. Screw the locknuts (102) onto the tie rods (103) loosely. Screw the displacement rod (13) into the shaft of the air motor (108) until the pin holes in the rod and shaft align. Install the cotter pin (111).
3. Apply thread sealant to the pump fluid outlet (R) and the threads of the fluid hose. Mount the pump and reconnect all hoses. Reconnect the ground wire if it was disconnected during repair. Tighten the packing nut/wet-cup (2) so it is just snug – no tighter. Fill the wet-cup with Graco Throat Seal Liquid or compatible solvent.
4. Tighten the tie rod locknuts (102) evenly, and torque as shown in Fig 4.
5. Start the pump and run it at about 40 psi (0.3 MPa, 2.8 bar) air pressure, to check that it is operating properly.
6. Check for fluid leakage at the packing nut/wet-cup (2). Follow the **Pressure Relief Procedure** on page 8 before tightening the packing nut/wet-cup.

Model 224342 Shown

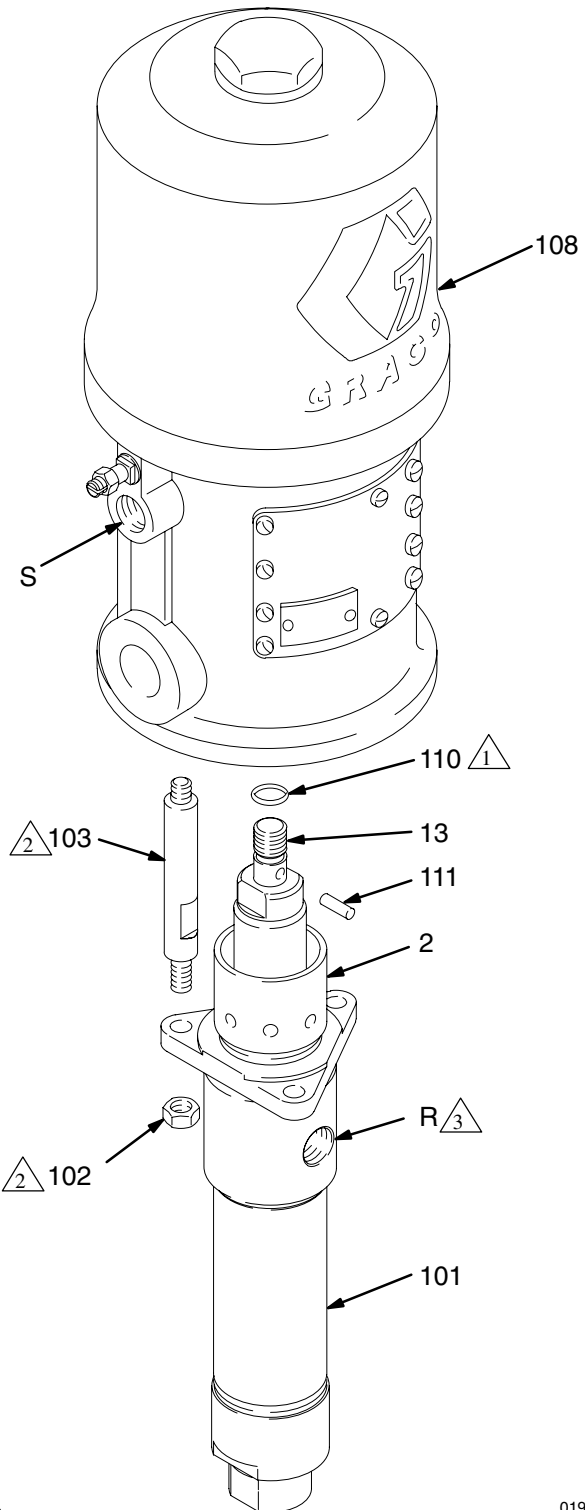

△ 1 Lubricate.

△ 2 **Model 224342:** Torque to 20–30 ft-lb (27–41 N•m).
Models 224343, 902147, 247147: Torque to 10–15 ft-lb (14–20 N•m).

△ 3 Apply sealant, as required.

0194

Fig. 4

Service

Displacement Pump Service

Disassembly

When disassembling the pump, lay out all removed parts in sequence, to ease reassembly. Refer to Fig 5.

NOTE: Standard Repair Kit 224401 (UHMWPE/PTFE packings) is available. For the best results, use all the new parts in the kit. Parts included in the kit are denoted with one asterisk, for example (3*).

Conversion Kit 224889 is available to convert the pump to all PTFE packings. See page 19 for details.

Clean all the parts thoroughly when disassembling. Check them carefully for damage or wear, replacing parts as needed.

1. Remove the displacement pump from the air motor as explained on page 12.
2. Unscrew the locking ring (7) from the cylinder (8). See Fig 5. Remove the intake valve housing (15).
3. Remove the o-ring (12), ball stop pin (6), ball guide (9) and ball (4) from the intake valve housing (15).
4. Loosen the packing nut (2). Push the displacement rod (13) down as far as possible, then pull it out the bottom of the cylinder (8).
5. Secure the flats of the displacement rod (13) in a vise. Using a wrench on the flats of the piston mounting stud (28), screw the piston off the rod. Remove one cotter pin (3) and the ball stop pin (21), taking note which set of holes it is in. Then remove the ball (4).
6. Place the flats of the piston mounting stud (28) in a vise, and unscrew the piston stud (26). Remove the piston packings (20, 23), glands (25, 27), washer (19), and shims (31).
7. Remove the packing nut (2), throat packings (5, 24), and glands (11, 14) from the outlet housing (1).
8. Inspect all parts for damage. Clean all parts and threads with a compatible solvent before reassembling. Inspect the polished surfaces of the displacement rod (13) and cylinder (8) for scratches, scoring or other damage, which can cause premature packing wear and leaking. To check, run a finger over the surface or hold the part up to the light at an angle. Be sure the ball seats of the piston (26) and intake valve housing (15) are not chipped or nicked. Replace any worn or damaged parts.

Reassembly

NOTE: On UHMWPE/PTFE packed pumps, the packing order is one UHMWPE packing, two PTFE packings, and one UHMWPE packing. On PTFE packed pumps, all four packings are PTFE.

1. See Fig 5 and the **NOTE** above. Lubricate the throat packings and install them in the outlet housing (1) one at a time as follows, *with the lips of the v-packings facing down*: the male gland (11*), the v-packings (24* or 5*), and the female gland (14*). Apply thread lubricant and install the packing nut (2) loosely.
2. If you removed the cylinder (8), apply thread lubricant and reinstall it in the outlet housing (1), making sure to replace the o-ring (10).
3. See Fig 5 and the **NOTE** above. Install shims (31*) onto the piston stud (26) as required to eliminate end play. Lubricate the piston packings and install them one at a time in the following order, *with the lips of the v-packings facing up*: the female gland (25*), the v-packings (23* or 20*), the male gland (27*), and the washer (19*).
4. Apply thread sealant and screw the piston stud (26) onto the piston mounting stud (28). Torque to 50–70 ft-lb (68–95 N•m). Install the piston ball (4*) on the piston seat. Slide the ball stop pin (21*) into the desired set of holes, and secure with the cotter pin (3*).
5. Place the flats of the displacement rod (13) in a vise. Apply sealant and screw the piston assembly onto the displacement rod. Torque to 50–70 ft-lb (68–95 N•m).
6. Insert the displacement rod (13) into the bottom of the cylinder (8), being careful not to scratch the cylinder. Push the rod straight up until it protrudes from the packing nut (2).
7. Install the ball (4*), guide (9), o-ring (12), and ball stop pin (6*) in the intake valve housing (15). Place the intake valve assembly in the locking ring (7). Apply thread sealant to the locking ring and cylinder (8), and screw the ring onto the cylinder.
8. Reconnect the displacement pump to the air motor as explained on page 12.

Service

Detail A: Throat Packings

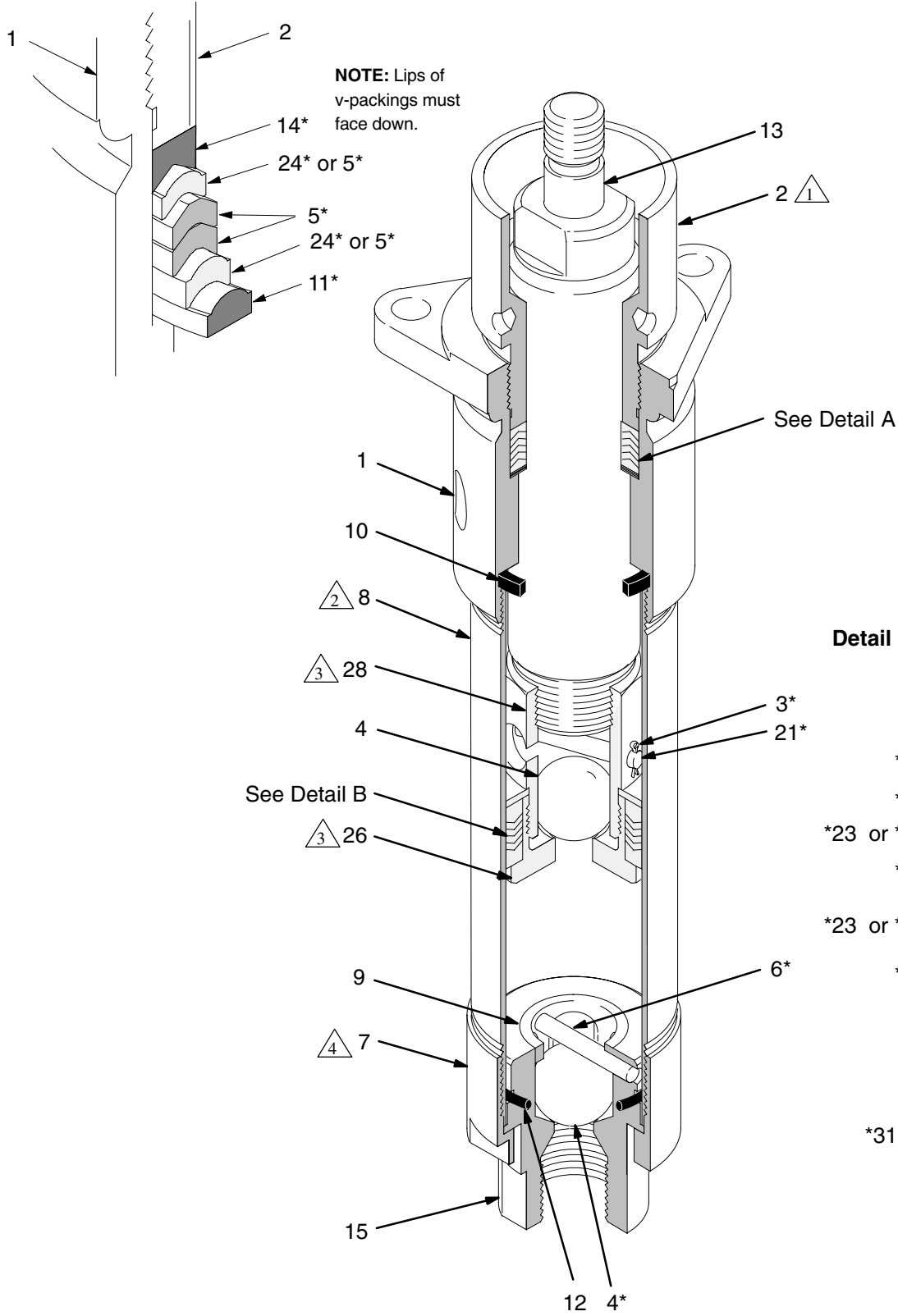

Detail B: Piston Packings

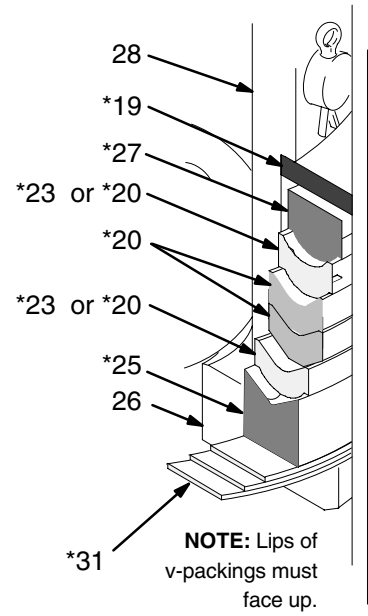
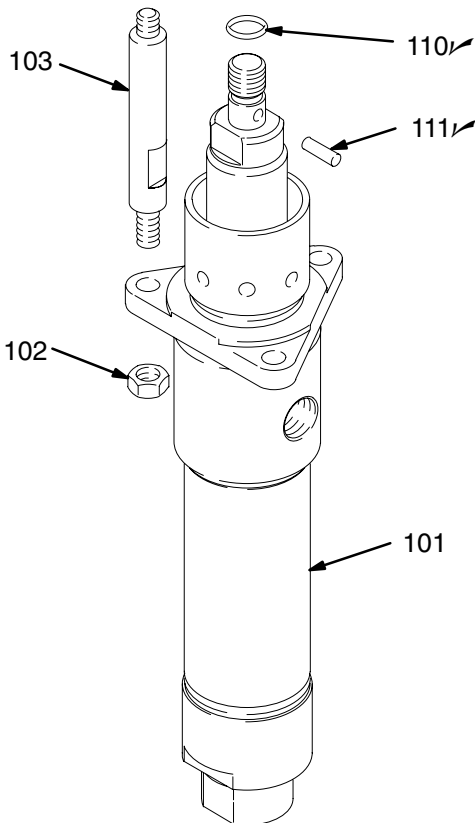
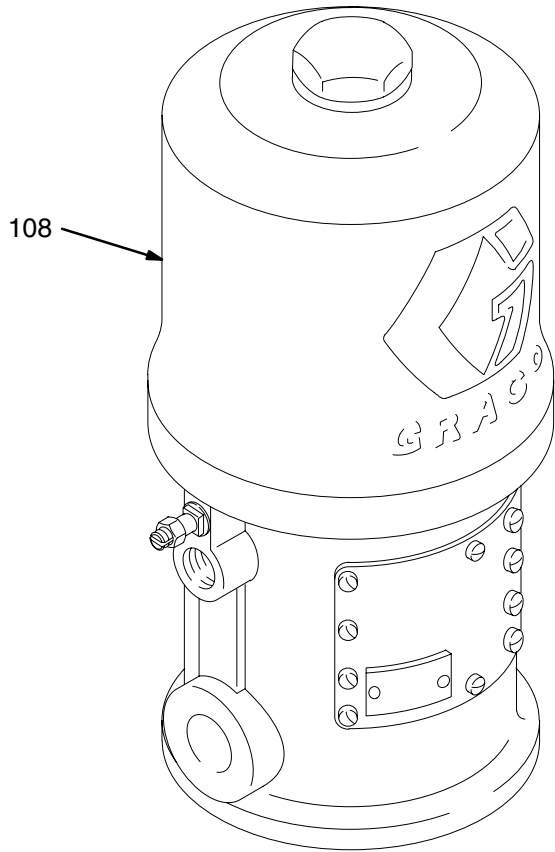

Fig. 5

0191C

Parts

Model 224342, Series A
10:1 Ratio President Pump
 Includes items 101–111



Ref No.	Part No.	Description	Qty
101	224341	DISPLACEMENT PUMP ASSY. See pages 18–19 for parts	1
102	102021	NUT, lock; 3/8–16; stainless steel	3
103	166237	ROD, tie; stainless steel; 3.5 in. (89 mm) shoulder to shoulder	3
108	207352	AIR MOTOR See 306982 for parts	1
110	156082 ✓	SEAL, o-ring; nitrile rubber	1
111	101946 ✓	PIN, cotter; stainless steel; 0.12 in. (3.2 mm) x 1.5 in. (3.8 mm)	1

✓ *Keep these spare parts on hand to reduce down time.*

Parts

Model 224343, Series A (shown)

5:1 Ratio Monark Pump

Includes items 101–111

Model 261630, Series A

5:1 Ratio Monark Pump

Includes items 101–111

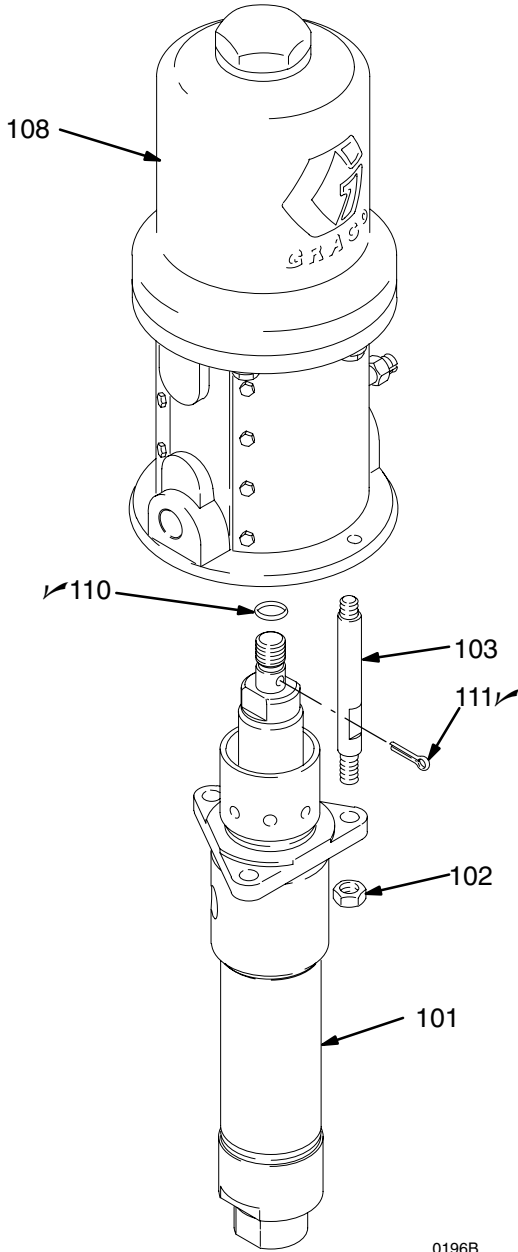

Ref No.	Part No.	Description	Qty
101	224341	DISPLACEMENT PUMP ASSY. for Model 224343 only; See pages 18–19 for parts	1
	254999	DISPLACEMENT PUMP ASSY. for Model 261630 only; See pages 18–19 for parts	1
102	102021	NUT, lock; 3/8–16; stainless steel	3
103	24B189	KIT, tie rod	3
108	205997	AIR MOTOR See 307043 for parts	1
110	156082 ✓	SEAL, o-ring; nitrile rubber	1
111	101946 ✓	PIN, cotter; stainless steel; 0.12 in. (3.2 mm) x 1.5 in. (3.8 mm)	1

✓ Keep these spare parts on hand to reduce down time.

0196B

Parts

Model 902147, Series A (shown)

5:1 Ratio Monark Pump

Includes items 101–116

Model 247147, Series A

5:1 Ratio Monark Pump

Includes items 101–111

 Items 112–116 used on Model 902147 only.

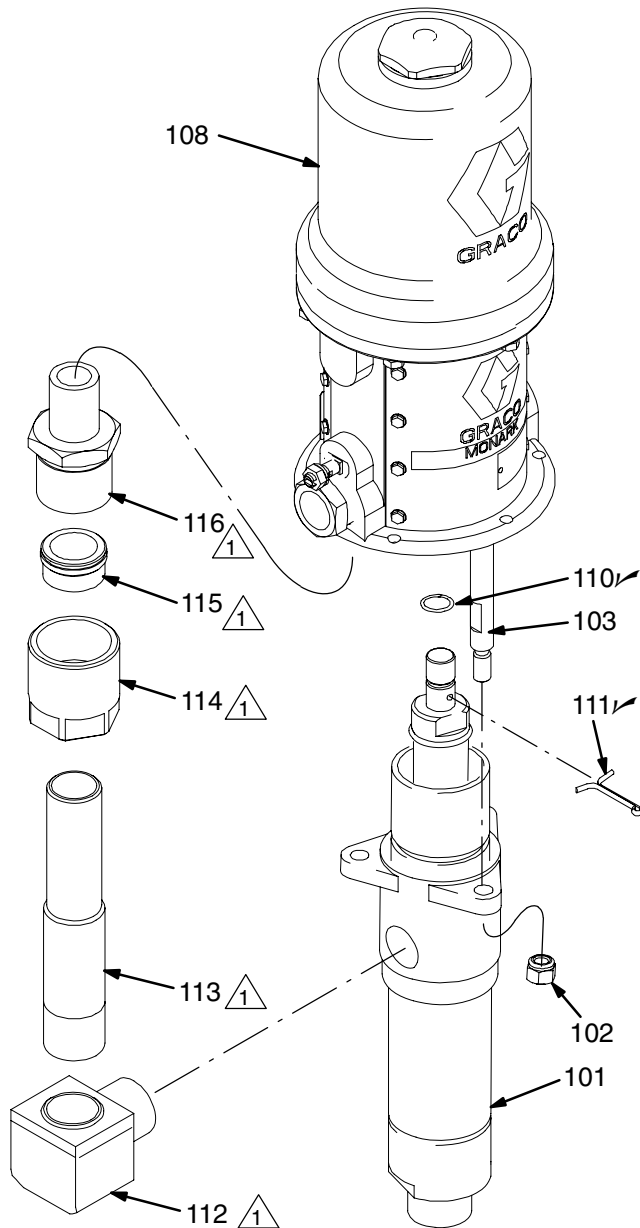

Ref No.	Part No.	Description	Qty
101	15G976	DISPLACEMENT PUMP ASSY. See pages 20–21 for parts	1
102	102021	NUT, lock; 3/8–16; sst	3
103	24B189	KIT, tie rod	3
108	205997	AIR MOTOR See 307043 for parts	1
110	156082 ✓	SEAL, o-ring; nitrile rubber	1
111	101946 ✓	PIN, cotter; stainless steel; 0.12 in. (3.2 mm) x 1.5 in. (3.8 mm)	1
112	166027	ELBOW, street; 90°; sst	1
113	166719	TUBE, rise; sst	1
114	166029	NUT, flareless tube; sst	1
115	102186	FERRULE, for 3/4 in. OD tube; sst	1
116	166030	ADAPTER, tube	1

✓ Keep these spare parts on hand to reduce down time.

Parts

Model 224341, Series A (shown)

Severe-Duty, UHMWPE/PTFE Packed Stainless Steel Displacement Pump

Includes items 1–31

Model 254999, Series A

Severe-Duty, UHMWPE/PTFE Packed Stainless Steel Displacement Pump

Includes items 1–33

 Items 6 and 7 used on Model 224341 only.

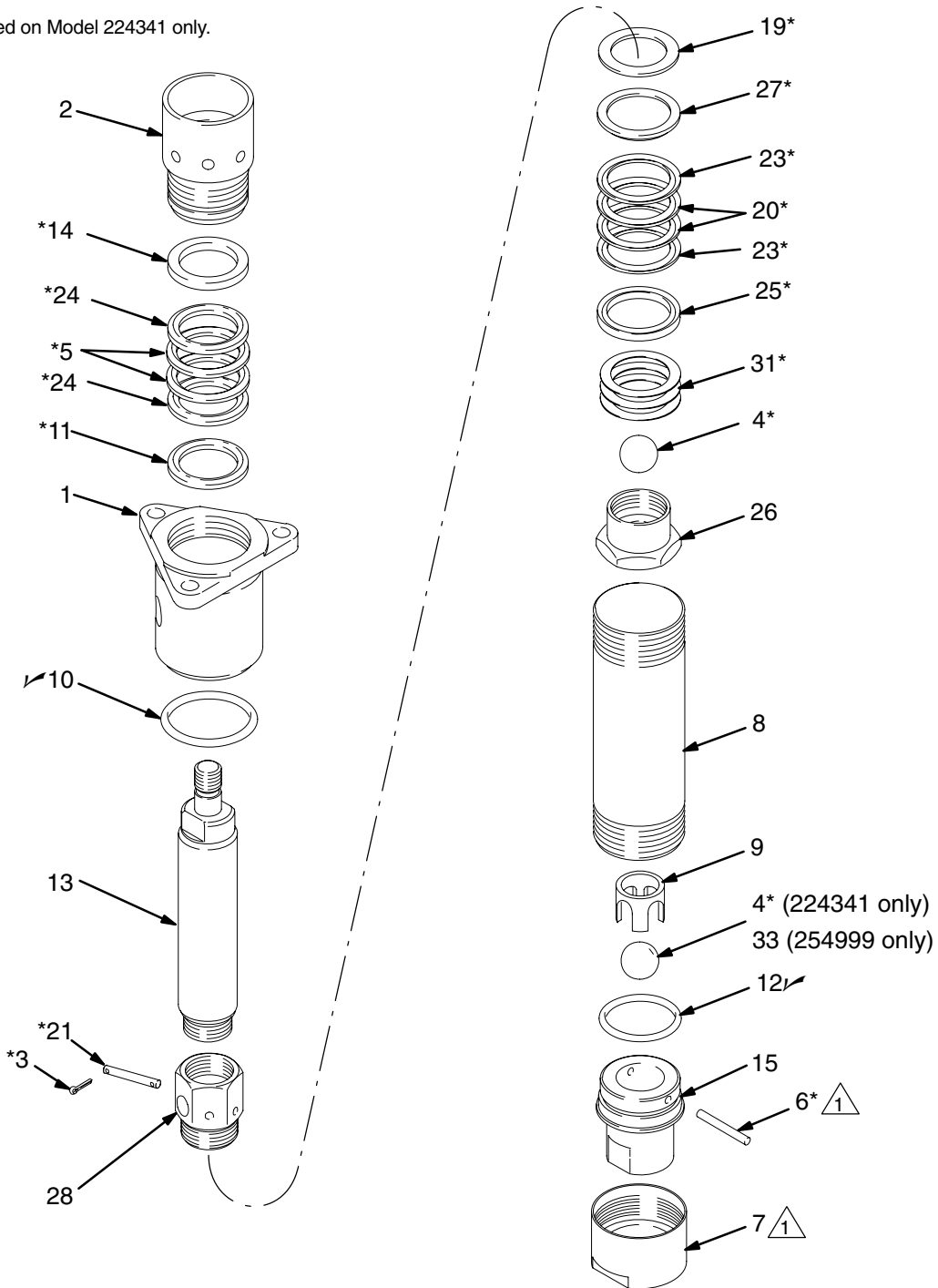

0190C

Parts

Model 224341, Series A

Severe-Duty, UHMWPE/PTFE Packed Stainless Steel Displacement Pump

Includes items 1–31

Model 254999, Series A

Severe-Duty, UHMWPE/PTFE Packed Stainless Steel Displacement Pump

Includes items 1–33

Ref. No.	Part No.	Description	Qty.	Ref. No.	Part No.	Description	Qty.
1	205999	HOUSING, outlet; stainless steel	1	21*	176637	PIN, ball stop, piston; stainless steel	1
2	186995	PACKING NUT/WET-CUP; stainless steel	1	23*	176638	V-PACKING, piston; UHMWPE	2
3*	100063	PIN, cotter; 1/16 in. x 1/2 in.; stainless steel	2	24*	176639	V-PACKING, throat; UHMWPE	2
4*	101917	BALL; stainless steel; 0.875 in. (22 mm) dia. (224341 only)	2	25*	186989	GLAND, piston, female; stainless steel	1
	101917	BALL; stainless steel; 0.875 in. (22 mm) dia. (254999 only)	1	26	186993	STUD, piston; stainless steel	1
5*	162866	V-PACKING, throat; PTFE	2	27*	186990	GLAND, piston, male; stainless steel	1
6*	162947	PIN, ball stop, intake; stainless steel (224341 only)	1	28	176644	STUD, mounting, piston; stainless steel	1
7	164630	RING, locking; stainless steel (224341 only)	1	31*	190484	SHIM (use as required)	3
8	186994	CYLINDER; stainless steel	1	33	101178	BALL, intake (254999 only)	1
9	164679	GUIDE, ball, intake; stainless steel (224341 only)	1	* These parts are included in Repair Kit 224401, which may be purchased separately. ✓ Keep these spare parts on hand to reduce down time.			
	15J577	RETAINER, ball, intake (254999 only)	1				
10✓	164782	O-RING; PTFE	1	Optional PTFE Packing Conversion Kit 224889			
11*	186987	GLAND, throat, male; stainless steel	1	Use to convert the pump to all PTFE packings. Kit must be purchased separately. Includes the following items:			
12✓	164846	O-RING; PTFE	1	Part No.	Description	Qty.	
	C38225	O-RING; fluoroelastomer (254999 only)	1	162866	V-PACKING; PTFE	4	
13	186997	ROD, displacement; stainless steel	1	186987	GLAND, throat, male; stainless steel	1	
14*	186988	GLAND, throat, female; stainless steel	1	186988	GLAND, throat, female; stainless steel	1	
15	186992	HOUSING, valve, intake; stainless steel (224341 only)	1	176635	V-PACKING, piston; PTFE	4	
	15J574	HOUSING, valve, intake (254999 only)	1	186989	GLAND, piston, female; stainless steel	1	
19*	176634	WASHER, piston; stainless steel	1	186990	GLAND, piston, male; stainless steel	1	
20*	176635	V-PACKING, piston; PTFE	2				

Parts

Model 15G976, Series A

Severe-Duty, PTFE Packed Stainless Steel Displacement Pump

Includes items 1–31

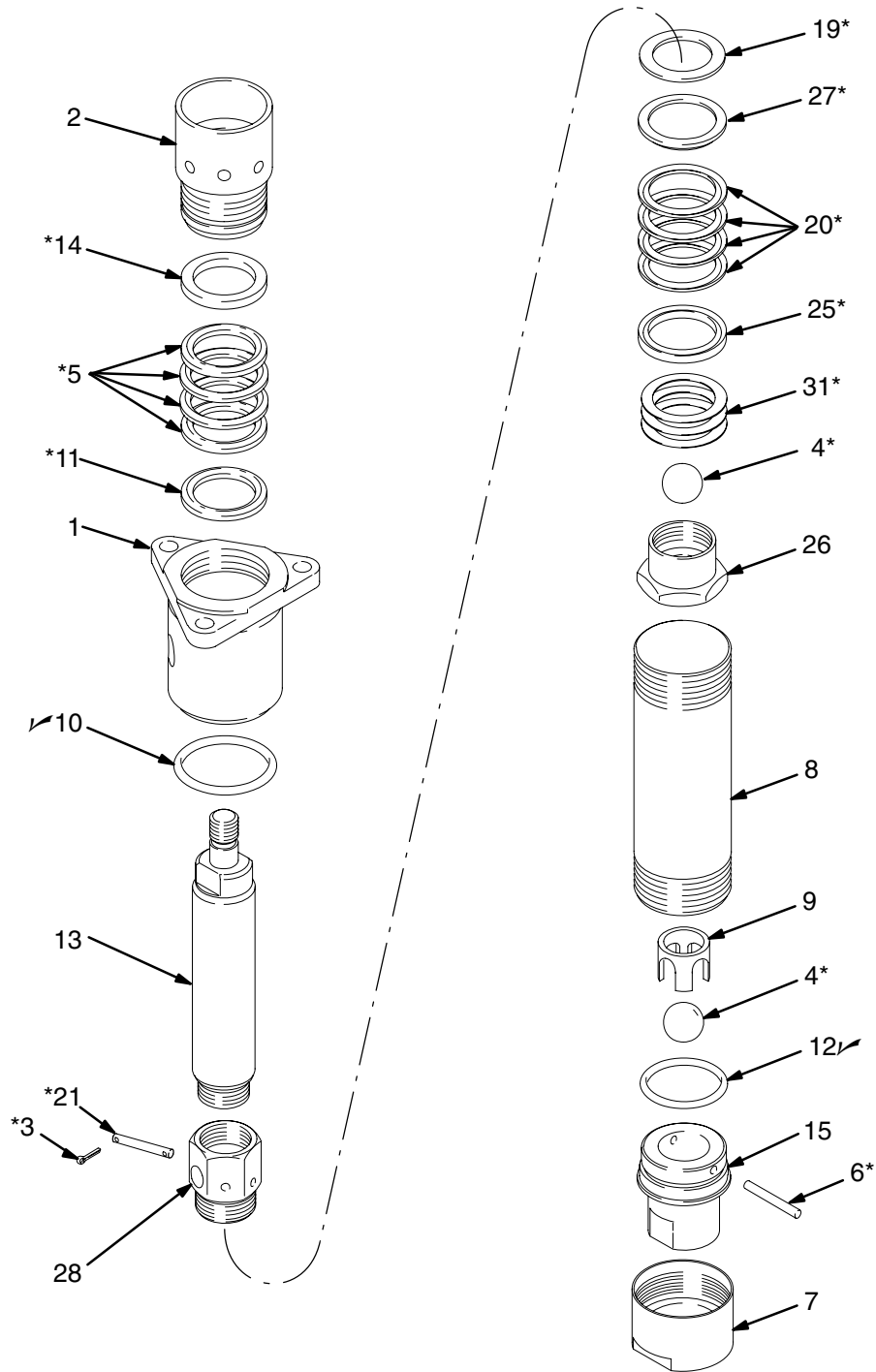

0190C

Parts

Model 15G976, Series A

Severe-Duty, PTFE Packed Stainless Steel Displacement Pump

Includes items 1–31

Ref. No.	Part No.	Description	Qty.	Ref. No.	Part No.	Description	Qty.
1	205999	HOUSING, outlet; stainless steel	1	13	186997	ROD, displacement; stainless steel	1
2	186995	PACKING NUT/WET-CUP; stainless steel	1	14*	186988	GLAND, throat, female; stainless steel	1
3*	100063	PIN, cotter; 1/16 in. x 1/2 in.; stainless steel	2	15	186992	HOUSING, valve, intake; stainless steel	1
4*	101917	BALL; stainless steel; 0.875 in. (22 mm) dia.	2	19*	176634	WASHER, piston; stainless steel	1
5*	162866	V-PACKING, throat; PTFE	4	20*	176635	V-PACKING, piston; PTFE	4
6*	162947	PIN, ball stop, intake; stainless steel	1	21*	176637	PIN, ball stop, piston; stainless steel	1
7	164630	RING, locking; stainless steel	1	25*	186989	GLAND, piston, female; stainless steel	1
8	186994	CYLINDER; stainless steel	1	26	186993	STUD, piston; stainless steel	1
9	164679	GUIDE, ball, intake; stainless steel	1	27*	186990	GLAND, piston, male; stainless steel	1
10✓	164782	O-RING; PTFE	1	28	176644	STUD, mounting, piston; stainless steel	1
11*	186987	GLAND, throat, male; stainless steel	1	31*	190484	SHIM (use as required)	3
12✓	164846	O-RING; PTFE	1				

* These parts are included in Repair Kit 224889, which may be purchased separately.

✓ Keep these spare parts on hand to reduce down time.

Technical Data

10:1 President

Category	Data
Maximum fluid working pressure	1800 psi (12.5 MPa, 125 bar)
Maximum air input pressure	180 psi (1.3 MPa, 12.5 bar)
Pump cycles per 1 gallon (3.8 liters)	20
Maximum recommended pump speed for continuous operation	60 cycles/min
Maximum flow at continuous duty	3 gallon (11.4 liters) at 60 cycles/min
Recommended speed for optimum pump life	15–25 cycles/min; 0.75–1.25 gpm (2.84–4.73 liters/min)
Air consumption	approx. 15 scfm (0.42 m ³ /min) at 1 gpm (3.8 liters/min) at 100 psi (0.7 MPa, 7 bar) air pressure
Weight	approx. 31 lb (14 kg)
Wetted parts	AISI 302, 303, 304, 316, and 17–4 PH grades of Stainless Steel; Chrome Plating; PTFE; Ultra-High Molecular Weight Polyethylene

KEY: Fluid Outlet Pressure – Black Curves
Air Consumption – Gray Curves

A 180 psi (1.3 MPa, 12.5 bar) air pressure
B 100 psi (0.7 MPa, 7 bar) air pressure
C 70 psi (0.5 MPa, 4.9 bar) air pressure
D 40 psi (0.3 MPa, 2.8 bar) air pressure

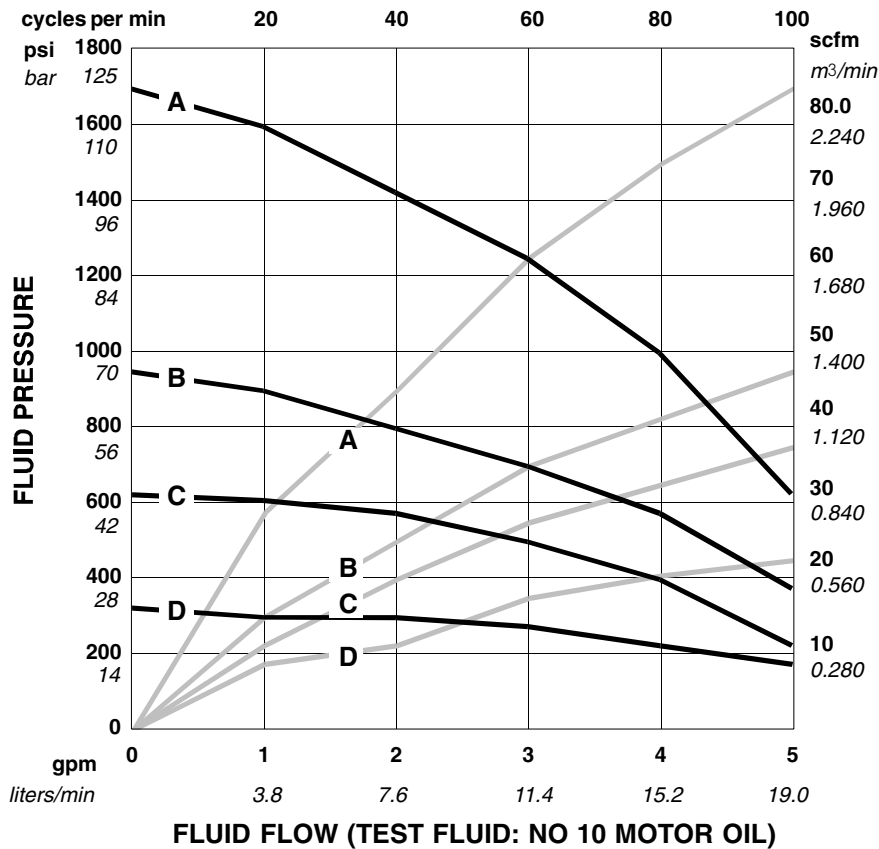

To find Fluid Outlet Pressure (bar/psi) at a specific fluid flow (lpm/gpm) and operating air pressure (bar/psi):

1. Locate desired flow along bottom of chart.
2. Follow vertical line up to intersection with selected fluid outlet pressure curve (black). Follow left to scale and read fluid outlet pressure.

To find Pump Air Consumption (m³/min or scfm) at a specific fluid flow (lpm/gpm) and operating air pressure (bar/psi):

1. Locate desired flow along bottom of chart.
2. Follow vertical line up to intersection with selected air consumption curve (gray). Follow right to scale and read air consumption.

Technical Data

5:1 Monark

Category	Data
Maximum fluid working pressure	600 psi (4.2 MPa, 42 bar)
Maximum air input pressure	120 psi (0.8 MPa, 8.4 bar)
Pump cycles per 1 gallon (3.8 liters)	24
Maximum recommended pump speed for continuous operation	60 cycles/min
Maximum flow at continuous duty	2.5 gallon (9.46 liters) at 60 cycles/min
Recommended speed for optimum pump life	15–25 cycles/min; 0.63–1.04 gpm (2.38–3.94 liters/min)
Air consumption	approx. 8.2 scfm (0.23 m ³ /min) at 1 gpm (3.8 liters/min) at 100 psi (0.7 MPa, 7 bar) air pressure
Weight	approx. 20 lb (9 kg)
Wetted parts	AISI 302, 303, 304, 316, and 17–4 PH grades of Stainless Steel; Chrome Plating; PTFE; Ultra-High Molecular Weight Polyethylene

KEY: Fluid Outlet Pressure – Black Curves
Air Consumption – Gray Curves

A 120 psi (0.8 MPa, 8.4 bar) air pressure
B 100 psi (0.7 MPa, 7 bar) air pressure
C 70 psi (0.5 MPa, 4.9 bar) air pressure
D 40 psi (0.3 MPa, 2.8 bar) air pressure

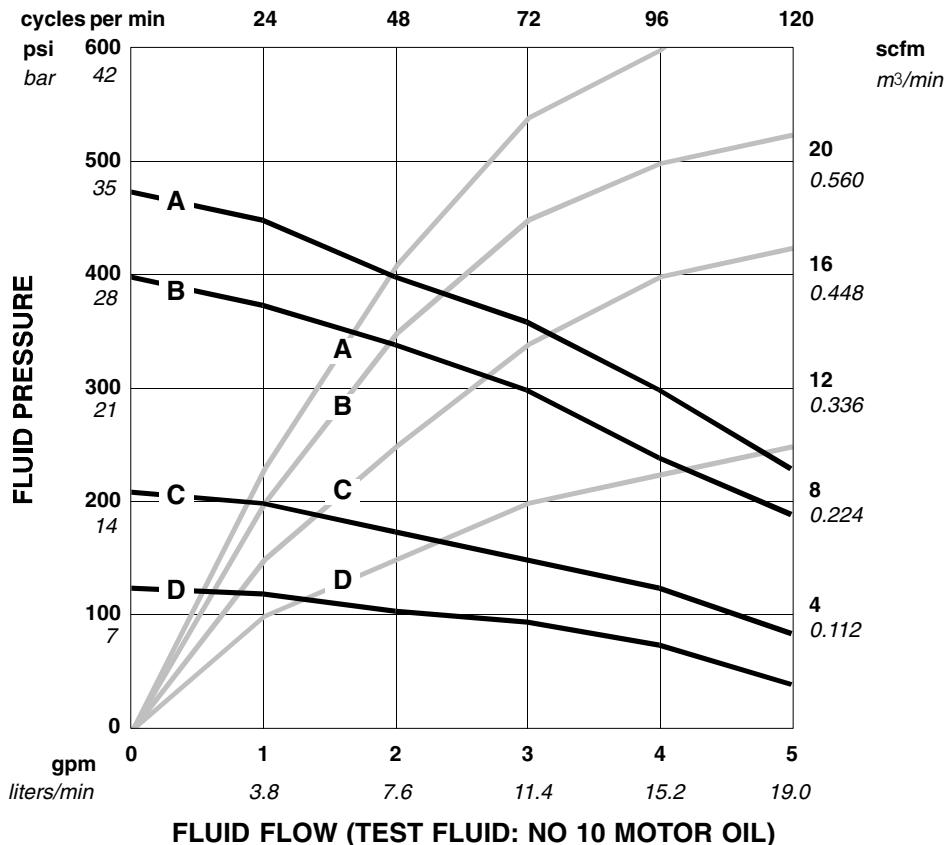

To find Fluid Outlet Pressure (bar/psi) at a specific fluid flow (lpm/gpm) and operating air pressure (bar/psi):

1. Locate desired flow along bottom of chart.
2. Follow vertical line up to intersection with selected fluid outlet pressure curve (black). Follow left to scale and read fluid outlet pressure.

To find Pump Air Consumption (m³/min or scfm) at a specific fluid flow (lpm/gpm) and operating air pressure (bar/psi):

1. Locate desired flow along bottom of chart.
2. Follow vertical line up to intersection with selected air consumption curve (gray). Follow right to scale and read air consumption.

Dimensions

Model 224342 Shown

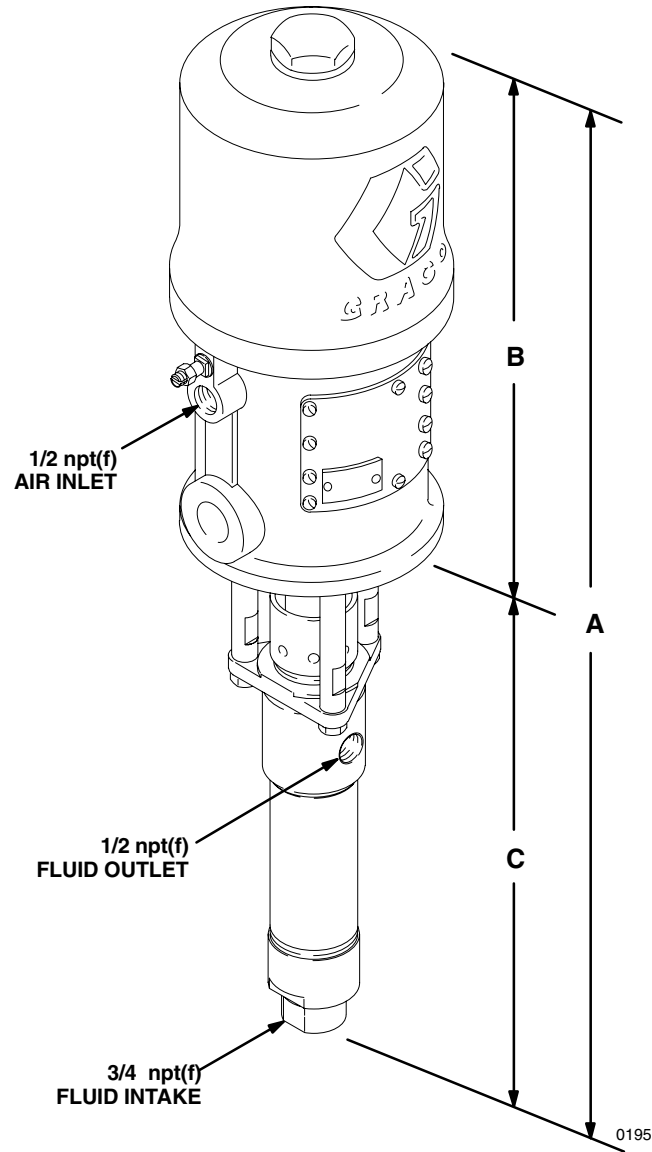

Mounting Hole Layout

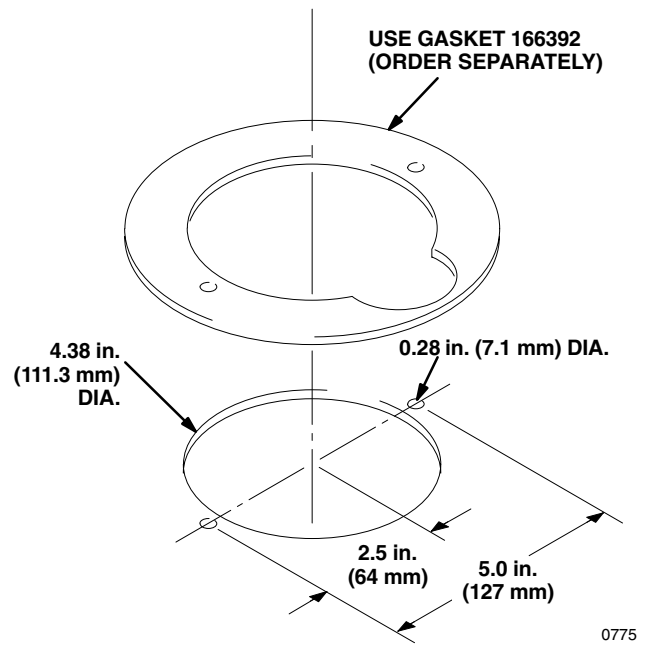

Pump Model	A	B	C
224342	28.38 in. (721 mm)	14.63 in. (372 mm)	13.75 in. (349 mm)
224343 902147 247147	25.25 in. (641 mm)	11.5 in. (292 mm)	13.75 in. (349 mm)
261630	26.25 (667 mm)	14.63 (372 mm)	13.75 in. (349 mm)

Graco Standard Warranty

Graco warrants all equipment manufactured by Graco and bearing its name to be free from defects in material and workmanship on the date of sale to the original purchaser for use. With the exception of any special, extended, or limited warranty published by Graco, Graco will, for a period of twelve months from the date of sale, repair or replace any part of the equipment determined by Graco to be defective. This warranty applies only when the equipment is installed, operated and maintained in accordance with Graco's written recommendations.

This warranty does not cover, and Graco shall not be liable for general wear and tear, or any malfunction, damage or wear caused by faulty installation, misapplication, abrasion, corrosion, inadequate or improper maintenance, negligence, accident, tampering, or substitution of non-Graco component parts. Nor shall Graco be liable for malfunction, damage or wear caused by the incompatibility of Graco equipment with structures, accessories, equipment or materials not supplied by Graco, or the improper design, manufacture, installation, operation or maintenance of structures, accessories, equipment or materials not supplied by Graco.

This warranty is conditioned upon the prepaid return of the equipment claimed to be defective to an authorized Graco distributor for verification of the claimed defect. If the claimed defect is verified, Graco will repair or replace free of charge any defective parts. The equipment will be returned to the original purchaser transportation prepaid. If inspection of the equipment does not disclose any defect in material or workmanship, repairs will be made at a reasonable charge, which charges may include the costs of parts, labor, and transportation.

THIS WARRANTY IS EXCLUSIVE, AND IS IN LIEU OF ANY OTHER WARRANTIES, EXPRESS OR IMPLIED, INCLUDING BUT NOT LIMITED TO WARRANTY OF MERCHANTABILITY OR WARRANTY OF FITNESS FOR A PARTICULAR PURPOSE.

Graco's sole obligation and buyer's sole remedy for any breach of warranty shall be as set forth above. The buyer agrees that no other remedy (including, but not limited to, incidental or consequential damages for lost profits, lost sales, injury to person or property, or any other incidental or consequential loss) shall be available. Any action for breach of warranty must be brought within two (2) years of the date of sale.

Graco makes no warranty, and disclaims all implied warranties of merchantability and fitness for a particular purpose in connection with accessories, equipment, materials or components sold but not manufactured by Graco. These items sold, but not manufactured by Graco (such as electric motors, switches, hose, etc.), are subject to the warranty, if any, of their manufacturer. Graco will provide purchaser with reasonable assistance in making any claim for breach of these warranties.

In no event will Graco be liable for indirect, incidental, special or consequential damages resulting from Graco supplying equipment hereunder, or the furnishing, performance, or use of any products or other goods sold hereto, whether due to a breach of contract, breach of warranty, the negligence of Graco, or otherwise.

FOR GRACO CANADA CUSTOMERS

The parties acknowledge that they have required that the present document, as well as all documents, notices and legal proceedings entered into, given or instituted pursuant hereto or relating directly or indirectly hereto, be drawn up in English. Les parties reconnaissent avoir convenu que la rédaction du présente document sera en Anglais, ainsi que tous documents, avis et procédures judiciaires exécutés, donnés ou intentés à la suite de ou en rapport, directement ou indirectement, avec les procédures concernées.

Graco Information

TO PLACE AN ORDER, contact your Graco distributor, or call one of the following numbers to identify the distributor closest to you:

1-800-328-0211 Toll Free

612-623-6921

612-378-3505 Fax

All written and visual data contained in this document reflects the latest product information available at the time of publication. Graco reserves the right to make changes at any time without notice.

This manual contains English. MM 308116

Graco Headquarters: Minneapolis
International Offices: Belgium, China, Japan, Korea

GRACO INC. P.O. BOX 1441 MINNEAPOLIS, MN 55440-1441

Copyright 1991, Graco Inc. is registered to ISO 9001

www.graco.com

Revised 12/2008