

Instructions – Parts List



2:1 Ratio Standard Pump

307026P

360 psi (25 bar) Maximum Fluid Working Pressure
180 psi (12.5 bar) Maximum Air Input Pressure

55 GALLON (200 LITER) DRUM SIZE

Model 226040, Series G
Stainless Steel, PTFE, Packed
Brevet No. 86-07085

5 GALLON (19 LITER) PAIL SIZE

Model 223954, Series B
Stainless Steel, PTFE Packed

Table of Contents

Symbols	2
Warnings	2
Installation	4
Operation	7
Troubleshooting	8
Pump Service (Model 226040)	10
Pump Service (Model 223954)	11
Pump Parts (Model 226040)	12
Pump Parts (Model 223954)	14
Accessories	16
Dimensions	18
Service Information	19
Technical Data	20
Graco Standard Warranty	22
Graco Information	22

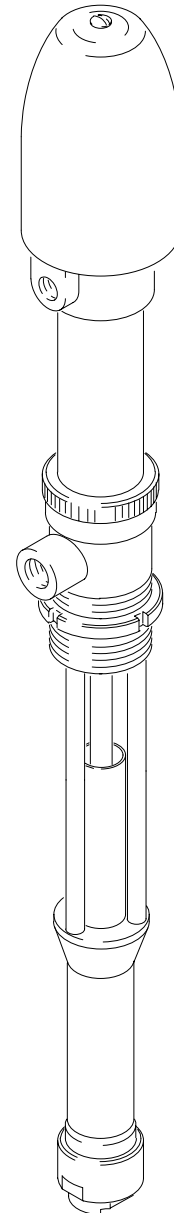

Model 223954 Shown



Read warnings and instructions.

PROVEN QUALITY. LEADING TECHNOLOGY.

GRACO INC. P.O. BOX 1441 MINNEAPOLIS, MN 55440-1441
Copyright 1970, Graco Inc. is registered to I.S. EN ISO 9001



0359



II 1/2 G T6
ITS03ATEX11227

Symbols

Warning Symbol



This symbol alerts you to the possibility of serious injury or death if you do not follow the instructions.

Caution Symbol



This symbol alerts you to the possibility of damage to or destruction of equipment if you do not follow the instructions.

WARNING



INSTRUCTIONS

EQUIPMENT MISUSE HAZARD

Equipment misuse can cause the equipment to rupture or malfunction and result in serious injury.

- This equipment is for professional use only.
- Read all instruction manuals, tags, and labels before operating the equipment.
- Use the equipment only for its intended purpose. If you are uncertain about usage, call your Graco distributor.
- Do not alter or modify this equipment. Use only genuine Graco parts and accessories.
- Check equipment daily. Repair or replace worn or damaged parts immediately.
- Do not exceed the maximum working pressure stated on the equipment or in the **Technical Data** for your equipment. Do not exceed the maximum working pressure of the lowest rated component in your system.
- Use fluids and solvents which are compatible with the equipment wetted parts. Refer to the **Technical Data** section of all equipment manuals. Read the fluid and solvent manufacturer's warnings.
- Securely mount the pump. Do not attempt to operate it while holding it.
- Do not use hoses to pull equipment.
- Route hoses away from traffic areas, sharp edges, moving parts, and hot surfaces. Do not expose Graco hoses to temperatures above 82°C (180°F) or below -40°C (-40°F).
- Wear hearing protection when operating this equipment.
- Do not lift pressurized equipment.
- Comply with all applicable local, state, and national fire, electrical, and safety regulations.

WARNING



FIRE AND EXPLOSION HAZARD

Improper grounding, poor ventilation, open flames or sparks can cause a hazardous condition and result in a fire or explosion and serious injury.

- Ground the equipment and the object being sprayed. Refer to **Grounding the System** on page 4.
- If there is any static sparking or you feel an electric shock while using this equipment, **stop spraying/dispensing immediately**. Do not use the equipment until you identify and correct the problem.
- Provide fresh air ventilation to avoid the buildup of flammable fumes from solvents or the fluid being sprayed/dispensed.
- Keep the spray/dispense area free of debris, including solvent, rags, and gasoline.
- Electrically disconnect all equipment in the spray/dispense area.
- Extinguish all open flames or pilot lights in the spray/dispense area.
- Do not smoke in the spray/dispense area.
- Do not turn on or off any light switch in the spray/dispense area while operating or if fumes are present.
- Do not operate a gasoline engine in the spray/dispense area.



TOXIC FLUID HAZARD

Hazardous fluid or toxic fumes can cause serious injury or death if splashed in the eyes or on the skin, inhaled, or swallowed.

- Know the specific hazards of the fluid you are using.
- Store hazardous fluid in an approved container. Dispose of hazardous fluid according to all local, state and national guidelines.
- Any additives to the air supply, such as oil or anti-freeze will be exhausted into the atmosphere.
- Always wear protective eyewear, gloves, clothing and respirator as recommended by the fluid and solvent manufacturer.



MOVING PARTS HAZARD

Moving parts can pinch or amputate your fingers.

- Keep clear of all moving parts when starting or operating the pump.
- Before servicing the equipment, follow the **Pressure Relief Procedure** on page 7 to prevent the equipment from starting unexpectedly.

Installation

General Information

1. The Typical Installation shown in Fig. 2 is only a guide for selecting and installing system components. Contact your Graco distributor for assistance in planning a system to suit your needs.
2. Always use Genuine Graco Parts and Accessories.
3. Reference numbers and letters in parentheses refer to the callouts in the figures and the parts lists on pages 12 through 15.

Grounding the System

⚠ WARNING	
	FIRE AND EXPLOSION HAZARD This pump must be grounded. Before operating the pump, ground the system as explained below. Also read the section FIRE AND EXPLOSION HAZARD on page 3.

To reduce the risk of static sparking, ground the pump and all other equipment used or located in the pumping area. Check your local electrical code for detailed grounding instructions for your area and type of equipment. **Ground all of this equipment.**

1. *Pump*: connect a ground wire and clamp as shown in Fig. 1. Loosen the air motor shield retaining screw (X). Connect one end of a 12 ga (1.5 mm²) minimum ground wire (Y) to the screw (X) and tighten the screw securely. See Fig. 1. Connect the other end of the wire to a true earth ground. See the ACCESSORIES section to order a ground wire and clamp.

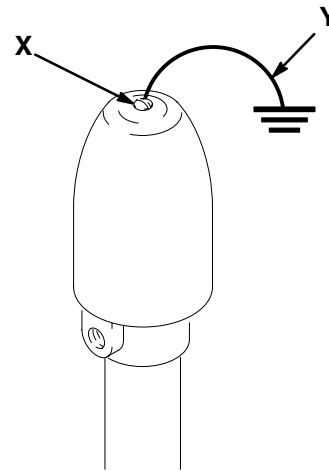
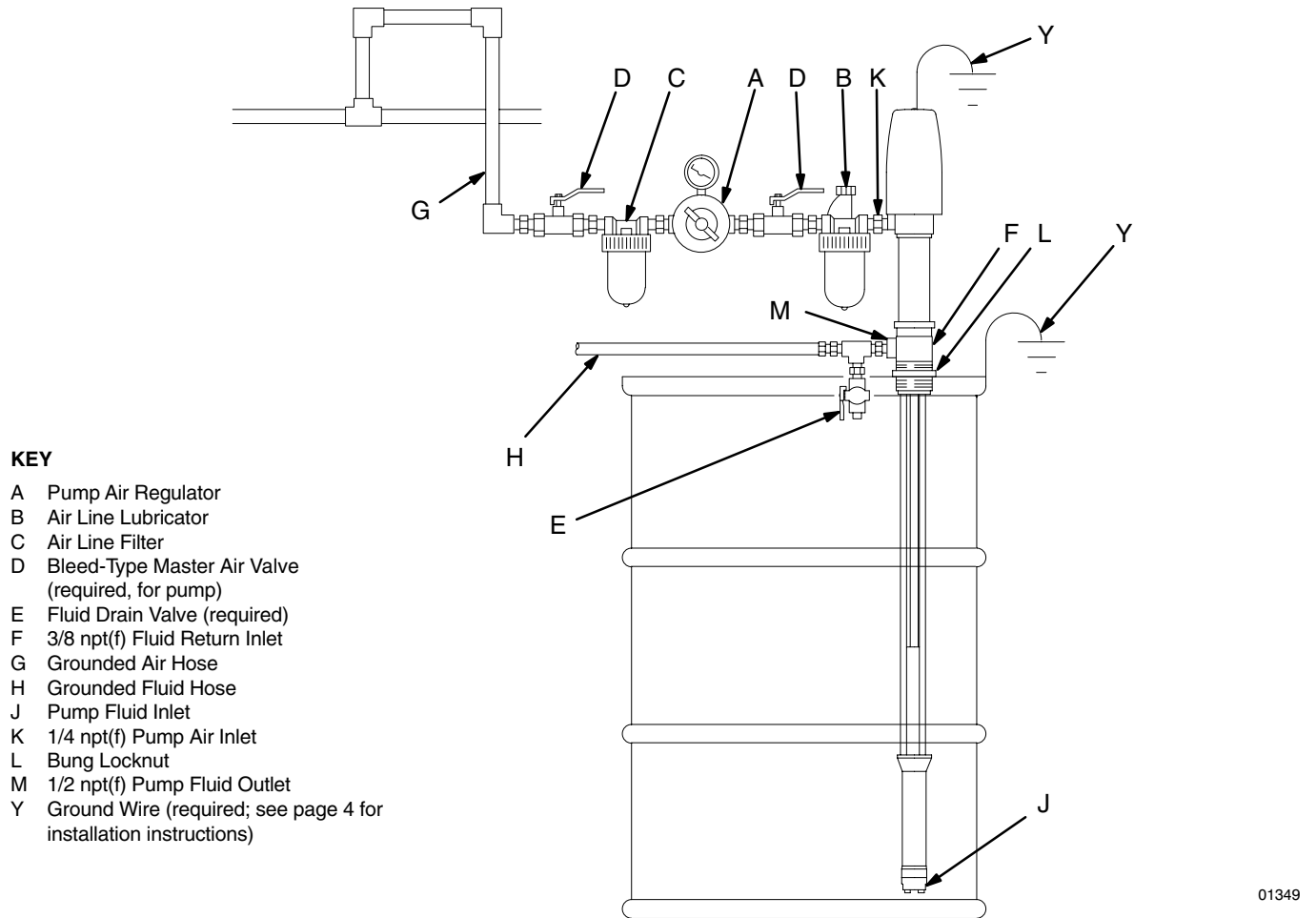

Fig. 1

2. *Air compressor*: according to manufacturer's recommendations.
3. *Fluid hoses*: use only grounded hoses with a maximum of 500 ft (150 m) combined hose length to ensure grounding continuity. Refer to Hose Grounding Continuity.
4. *Dispensing valve*: grounding is obtained through connection to a properly grounded fluid hose and pump.
5. *Object being sprayed*: according to local code.
6. *Fluid supply container*: according to local code.
7. *All solvent pails used when flushing*, according to local code. Use only metal pails, which are conductive. Do not place the pail on a non-conductive surface, such as paper or cardboard, which interrupts the grounding continuity.
8. *To maintain grounding continuity when flushing or relieving pressure*, always hold a metal part of the spray gun/dispensing valve firmly to the side of a grounded *metal* pail, then trigger the gun/valve.

Installation



01349

Fig. 2

Mounting the Pump

To mount the pump on a closed-head drum, screw the threaded pump base into the 2 in. npt bung hole and adjust to hold the pump 1/2 in. (13 mm) off the bottom of the drum or pail. The pump dimensions are shown on page 18. Turn the bung locknut (L) down to secure the pump in position. Loosen the drum vent plug to avoid creating a vacuum.

A clamp is available to mount the pump on an open-head drum. A bracket is available to wall mount Pump Model 223954. See Accessories on page 16.

Stainless Steel Pail Cover Accessory Kit 224302 is available for use in general purpose applications, to mount Pump Model 223954 to a 5 gallon (19 liter) pail. See page 17.

Pail Cover Accessory Kit 224004 is available for use in rotary label applications, to mount Pump Model 223954 to a 5 gallon (19 liter) pail. See page 17.

Installation

System Accessories

Refer to Fig. 2 and the Accessories section.

NOTE: To ensure maximum pump performance, be sure that all accessories used are properly sized to meet your system's requirements.

WARNING

A bleed-type master air valve (D) and a fluid drain valve (E) are required in your system, to help reduce the risk of serious injury, including splashing fluid in the eyes or on the skin, and injury from moving parts if you are adjusting or repairing the pump.

The *bleed-type master air valve* (D) relieves air trapped between this valve and the pump after the pump is shut off. Trapped air can cause the pump to cycle unexpectedly and result in serious injury, including amputation. Locate the valve close to the pump.

The *fluid drain valve* (E) helps relieve pressure in the displacement pump, hose, and dispensing valve when shutting off the pump. Actuating the dispensing valve to relieve pressure may not be sufficient, especially if there is a clog in the hose or the dispensing valve.

Air Line Accessories

Install the following accessories in the order shown in the Typical Installation, using adapters as necessary:

- **An air line lubricator (B)** provides automatic air motor lubrication.
- **A bleed-type master air valve (D)** is required in your system to relieve air trapped between it and the air motor when the valve is closed (see the **WARNING** above). Be sure the bleed valve is easily accessible from the pump, and is located **downstream** from the air regulator.
- **An air regulator (A)** controls pump speed and outlet pressure by adjusting the air pressure to the pump. Locate the regulator close to the pump, but **upstream** from the bleed-type master air valve.

- **An air line filter (C)** removes harmful dirt and moisture from the compressed air supply.
- **A second bleed-type air valve (D)** isolates the air line accessories for servicing. Locate upstream from all other air line accessories.

Fluid Line Accessories

A fluid drain valve (E) is required in your system to relieve fluid pressure in the hose and gun (see the **WARNING** at left). Install the drain valve pointing down, but so the handle points up when the valve is opened.

CONNECT THE HOSES

Connect a grounded air supply hose (G) to supply air to the pump's 1/4 npt(f) air inlet (K). Connect a grounded fluid hose (H) to the 1/2 npt(f) fluid outlet (M). In a circulating system, remove the pipe plug and connect a fluid return line to the 3/8 npt(f) return port (F). See Fig. 3 and the Typical Installation drawing, Fig. 2.

To use Model 223954 in a fixed mounting, connect a supply line to the 3/4 npt fluid inlet (J).

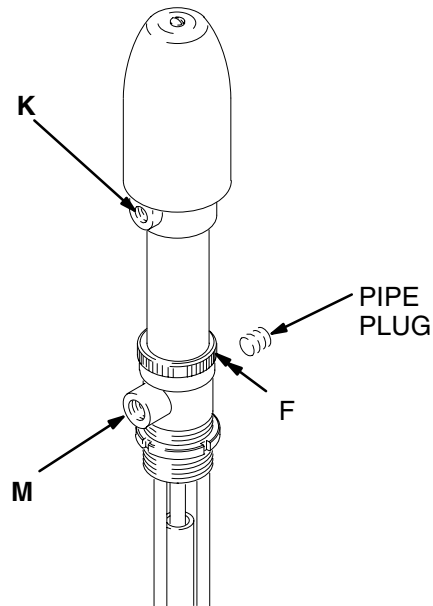

01351

Fig. 3

Operation

Pressure Relief Procedure

⚠ WARNING

PRESSURIZED EQUIPMENT HAZARD

The system pressure must be manually relieved to prevent the system from starting or spraying accidentally. To reduce the risk of an injury from accidental spray from the gun, splashing fluid, or moving parts, follow the **Pressure Relief Procedure** whenever you:

- are instructed to relieve the pressure,
- stop spraying,
- check or service any of the system equipment,
- or install or clean the spray nozzle.

1. Shut off the air to the pump.
2. Close the bleed-type master air valve (required in your system).
3. Hold a metal part of the dispensing valve firmly to the side of a grounded metal pail, and trigger the valve to relieve pressure.
4. Open the fluid drain valve (required in your system) to relieve all fluid pressure, having a container ready to catch the drainage.
5. Leave the drain valve open until you are ready to dispense again.

*If you suspect that the nozzle or hose is completely clogged, or that pressure has not been fully relieved after following the steps above, **very slowly** loosen the hose end coupling and relieve pressure gradually, then loosen completely. Now clear the nozzle or hose.*

Flush the Pump Before Using

The pump was tested in lightweight oil, which was left in to protect pump parts. To prevent contamination of the fluid you are pumping, flush the pump with a compatible solvent before using it.

To flush the pump, connect a short hose to the pump outlet, insert the pump intake into a pail of compatible solvent, direct the hose into a pail, and start the pump as explained at right.

Cycle the pump slowly for at least 5 minutes, then stop and disconnect the air hose. Push up on the ball of the intake valve (J) to drain the lower part of the pump. See Fig. 4. Turn the pump over to drain the upper part of the pump.

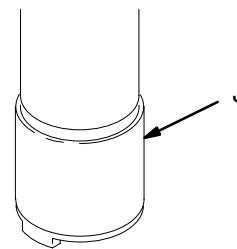

Fig. 4

03765

Starting and Adjusting the Pump

1. Mount the pump and connect to a fluid supply as explained on page 5.
2. See the **INSTALLATION** on page 6. Be sure the air regulator (A) and bleed-type master air valve (D) are closed.
3. Hold a metal part of the spray gun/dispensing valve firmly to the side of a grounded metal pail and hold the trigger open. Then open the pump's bleed-type master air valve (D). Now slowly open the air regulator (A) until the pump starts.
4. Run the pump slowly until all the air is pushed out of the pump and hose. Always use the lowest pressure necessary to get the desired results. Higher pressures waste fluid and cause premature system wear.
5. After all the air is purged, release the gun/dispensing valve trigger. *In a direct supply system*, the pump will start and stop as the gun/valve is opened and closed. *In a circulating system*, the pump will run continuously and will speed up or slow down as supply demands, until the air supply is shut off.

Never allow the pump to run dry of the fluid being pumped. A dry pump will quickly accelerate to a high speed, possibly damaging itself. If your pump accelerates quickly, or is running too fast, stop it immediately and check the fluid supply. If the supply container is empty and air has been pumped into the lines, refill the container and prime the pump and the lines with fluid, or flush and leave it filled with a compatible solvent. Be sure to eliminate all air from the fluid system.

Shutdown and Care of the Pump

For overnight shutdown, follow the **Pressure Relief Procedure Warning** at left. Always stop the pump at the bottom of the stroke to prevent the fluid from drying on the exposed displacement rod and damaging the throat packings.

Operation

Corrosion Protection for Pump

CAUTION

Water, or even moist air, can cause your pump to corrode. To help prevent corrosion, NEVER leave the pump filled with water or air. After normal flushing, flush the pump again with mineral spirits or oil-based solvent, relieve pressure, and leave the mineral spirits in the pump. Be sure to follow the **Pressure Relief Procedure Warning** at left.

Lubrication

If you are not using an accessory air line lubricator, manually lubricate the motor daily. Disconnect the air regulator, place about 15 drops of light machine oil in the pump air inlet, reconnect the regulator and turn on the air supply to blow oil into the motor.

Troubleshooting

WARNING

To reduce the risk of serious injury whenever you are instructed to relieve pressure, always follow the **Pressure Relief Procedure** on page 7.

1. Relieve the pressure.
2. Check all other possible remedies before disassembling the pump.

PROBLEM	CAUSE	SOLUTION
The pump fails to operate.	Dirty or worn air motor.	Clean, service; see the separate motor manual 307851.
	Inadequate air supply or restricted lines.	Clean lines or increase the air supply (see Technical Data).
	Closed or clogged air valves.	Open or clear the valves.
	Clogged fluid hose or valve.	Clear the hose or valves.
	Worn or damaged valves or seals.	Service the valves or seals.
The pump operates, but the output is low on both strokes.	Clogged fluid hose or valve.	Clear the hose or valves.
	Exhausted fluid supply.	Refill the fluid supply and reprime the pump.
	Worn or damaged valves or seals.	Service the valves or seals.
The pump operates, but the output is low on the downstroke.	Held open or worn intake valve.	Clear or service the valve.
	Worn or damaged valves or seals.	Service the valves or seals.
The pump operates, but the output is low on the upstroke.	Held open or worn piston valve.	Clear or service the valve.
	Worn or damaged valves or seals.	Service the valves or seals.
Erratic or accelerated operation.	Exhausted fluid supply.	Refill the fluid supply and reprime the pump.
	Broken air motor compression spring.	Replace the spring.

Pump Service (Model 226040)

BEFORE YOU START

1. Have all the necessary repair parts on hand. Recommended spare parts are marked with an asterisk (for example, 113*). Tool 233582, mentioned in this procedure, is located on the accessories page of this manual.
2. Repair Kit 224005 is available. For the best results, use all the new parts in the kit. Parts in the kit are marked with two asterisks (for example, 107**).
3. Use a compatible solvent to clean parts. Inspect parts for wear or damage and replace as needed.
4. Flush the pump if possible. Stop the pump at the bottom of its stroke. Follow the **Pressure Relief Procedure Warning** on page 7.
5. Disconnect the air and fluid hoses. Remove the pump from its mounting. Clamp the pump in a vise.

SERVICING THE DISPLACEMENT PUMP

1. Unscrew the air motor connecting ring (AA). Lay the pump on its side and rotate the displacement pump until the ball on the upper connecting rod (120) comes free of the socket in the motor piston rod. Separate the motor from the displacement pump.

NOTE: To service the air motor, refer to separate manual 307851, supplied.

2. Unscrew the intake valve housing (117) from the pump frame (119). Disassemble the intake valve.
3. Push down on the upper connecting rod (120) until the fluid piston assembly is clear of the displacement pump frame (119). Pull the piston assembly and connecting rod out of the frame. Remove the bearing (118) and seal (134**) from the frame.

NOTE: Scoring or irregular surfaces on the connecting rods (120, 115) or polished inner wall of the pump frame (119) can cause premature packing wear and leaking. To check these parts, rub a finger over the surface or hold the part up to the light at an angle.

4. Unscrew the piston valve housing (109) from the lower connecting rod (115). Unscrew the piston body (113) from the piston valve housing (109).
5. Unscrew the lower connecting rod (115) from the upper connecting rod (120). Remove the cup packings (107), bearing (108) and backup washer (114).
6. Lubricate the packings (107**) and bearing (108**) with no. 2 lithium-based grease. Install the backup washer (114) on the lower connecting rod (115), making certain that the grooves face up.

7. On the upper connecting rod (120), install one cup packing (107**) with the lips facing up, the bearing (108**), and the second packing (107**) with the lips facing down. Reconnect the upper and lower connecting rods. Torque to 20-25 ft-lb (27-34 N.m).
8. Lubricate the packings (111**) and bearing (112**) with no. 2 lithium-based grease. On the piston (113), install one cup packing (111**) with the lips facing down, the bearing (112**), and the second packing (111**) with lips facing up. Install the backup washer (110), with the grooves facing down.
9. Place the ball (104**) atop the piston body (113), then screw the piston body and piston housing (109) together. Torque to 30-35 ft-lb (41-48 N.m). Screw the piston valve housing onto the lower connecting rod (115). Install the seal (134**), *with the lips facing down*, in the displacement pump frame (119), then install the bearing (118**). The seal (134**) should be installed from the bottom of the frame using tool 233582. See fig. 5. Use a turning motion to work the connecting rod and piston back into the pump frame (119).

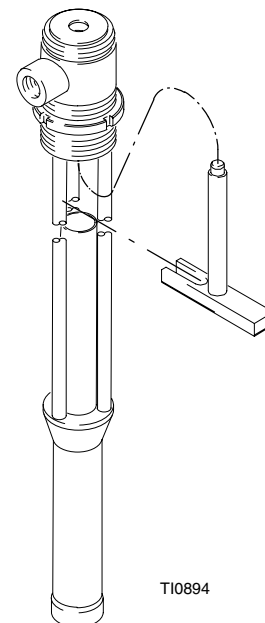

Fig. 5

10. Reinstall the ball (105**) and ball stop pin (116) in the intake valve housing (117), and screw the housing into the displacement pump frame (119).
11. Lay the pump on its side and reconnect the upper connecting rod (120) with the air motor piston rod. Tighten the air motor connecting ring (AA).
12. Reinstall the pump on its mounting. If the grounding wire was disconnected during service, reconnect it before operating the pump.

Pump Service (Model 223954)

BEFORE YOU START

1. Have all the necessary repair parts on hand. Recommended spare parts are marked with an asterisk (for example, 313*). Tool 233583, mentioned in this procedure, is located on the accessories page of this manual.
2. Repair Kit 224005 is available. For the best results, use all the new parts in the kit. Parts in the kit are marked with two asterisks (for example, 307**).
3. Use a compatible solvent to clean parts. Inspect parts for wear or damage and replace as needed.
4. Flush the pump if possible. Stop the pump at the bottom of its stroke. Follow the **Pressure Relief Procedure Warning** on page 7.
5. Disconnect the air and fluid hoses. Remove the pump from its mounting. Clamp the pump in a vise.
4. Unscrew the piston valve housing (309) from the lower connecting rod (315). Unscrew the piston body (313) from the piston valve housing (309).
5. Unscrew the lower connecting rod (315) from the upper connecting rod (320). Remove the cup packings (307), bearing (308) and backup washer (314).
6. Lubricate the packings (307**) and bearing (308**) with no. 2 lithium-based grease. Install the backup washer (314) on the lower connecting rod (315), making certain that the grooves face up.
7. On the upper connecting rod (320), install one cup packing (307**) with the lips facing up, the bearing (308**), and the second packing (307**) with the lips facing down. Reconnect the upper and lower connecting rods. Torque to 20-25 ft-lb (27-34 N.m).

SERVICING THE DISPLACEMENT PUMP

1. Unscrew the air motor connecting ring (AA). Lay the pump on its side and rotate the displacement pump until the ball on the upper connecting rod (320) comes free of the socket in the motor piston rod. Separate the motor from the displacement pump.
- NOTE:** To service the air motor, refer to separate manual 307851, supplied.
2. Unscrew the intake adapter (321) from the intake valve housing (317). Remove the o-ring (322). Unscrew the intake valve housing (317) from the pump frame (319). Disassemble the intake valve.
3. Push down on the upper connecting rod (320) until the fluid piston assembly is clear of the displacement pump frame (319). Pull the piston assembly and connecting rod out of the frame. Remove the bearing (318) and seal (334**) from the frame.
- NOTE:** Scoring or irregular surfaces on the connecting rods (320, 315) or polished inner wall of the pump frame (319) can cause premature packing wear and leaking. To check these parts, rub a finger over the surface or hold the part up to the light at an angle.
6. Lubricate the packings (311**) and bearing (312**) with no. 2 lithium-based grease. On the piston (313), install one cup packing (311**) with the lips facing down, the bearing (312**), and the second packing (311**) with the lips facing up. Install the backup washer (310) with the grooves facing down.
9. Place the ball (304**) atop the piston body (313), then screw the piston body and piston housing (309) together. Torque to 30-35 ft-lb (41-48 N.m). Screw the piston valve housing onto the lower connecting rod (315). Install the seal (334**), *with the lips facing down*, in the pump frame (319), then install the bearing (318**). The seal (334**) should be installed from the bottom of the frame using tool 233583. See fig. 5. Use a turning motion to work the connecting rod and piston into the frame (319).
10. Reinstall the ball (305**) and stop pin (316) in the intake valve housing (317). Screw the housing into the pump frame (319). Place the o-ring (322**) into the inner groove of the intake adapter (321). Screw the adapter onto the intake valve housing (317).
11. Lay the pump on its side and reconnect the upper connecting rod (320) with the air motor piston rod. Tighten the air motor connecting ring (AA).
12. Reinstall the pump on its mounting. If the grounding wire was disconnected during service, reconnect it before operating the pump.

Pump Parts

Model 226040, Series G
Stainless Steel, PTFE Packed

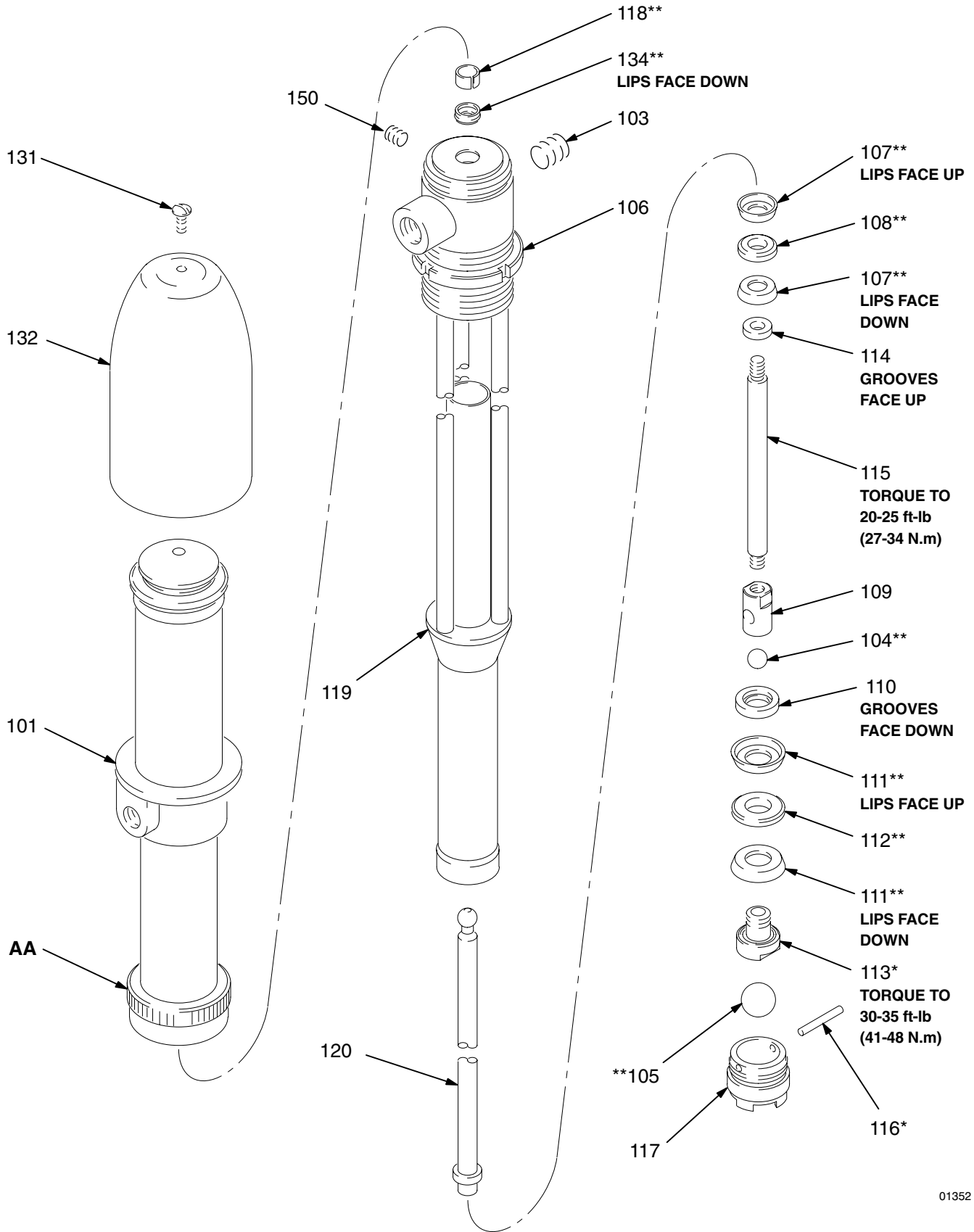

01352

Pump Parts

Model 226040, Series G Stainless Steel, PTFE Packed

Ref. No.	Part No.	Description	Qty.	REF NO.	PART NO.	DESCRIPTION	QTY
101	204722	AIR MOTOR; See 307851 for parts	1	118	166564**	. BEARING, connecting rod	1
102	204724	DISPLACEMENT PUMP ASSY Series F Includes items 103-120, 134	1	119	204725	. FRAME, displacement pump	1
103	101748	. PLUG, pipe	1	120	204885	. ROD, upper connecting; 32.84" (854 mm) long	1
104	101750**	. BALL, piston valve	1	131	101870	SCREW, shield retaining	1
105	101917**	. BALL, intake valve	1	132	164796	SHIELD, air motor	1
106	161784	. NUT, bung lock; 2" npsm	1	134	111791**	SEAL; glass-reinforced PTFE; with stainless steel spring	1
107	161788**	. PACKING, cup; PTFE	2	150	104071	PLUG, pipe	1
108	186647**	. BEARING, piston; PEEK	1		223582‡	TOOL, insert	1
109	161791	. HOUSING, piston valve	1	* Recommended "tool box" spare parts. Keep on hand to reduce downtime.			
110	161792	. WASHER, back-up; stainless steel	1				
111	161793**	. PACKING, cup; PTFE	2	** Included in Repair Kit 224005.			
112	186648**	. BEARING, piston; PEEK	1	‡ This tool is ordered as a separate part item. It is located on the accessories page of this manual.			
113	161795*	. BODY, piston	1	307 number in description refers to separate instruction manual, supplied.			
114	162238	. WASHER, back-up; stainless steel	1	Conversion Kit 224017 is available to convert the pump to UHMWPE packings. Refer to the Accessories section.			
115	162239	. ROD, lower connecting; 6.67" (169.4 mm) long	1				
116	164250*	. PIN, ball stop	1				
117	164251	. HOUSING, intake valve	1				

Pump Parts

Model 223954, Series B
Stainless Steel, PTFE Packed

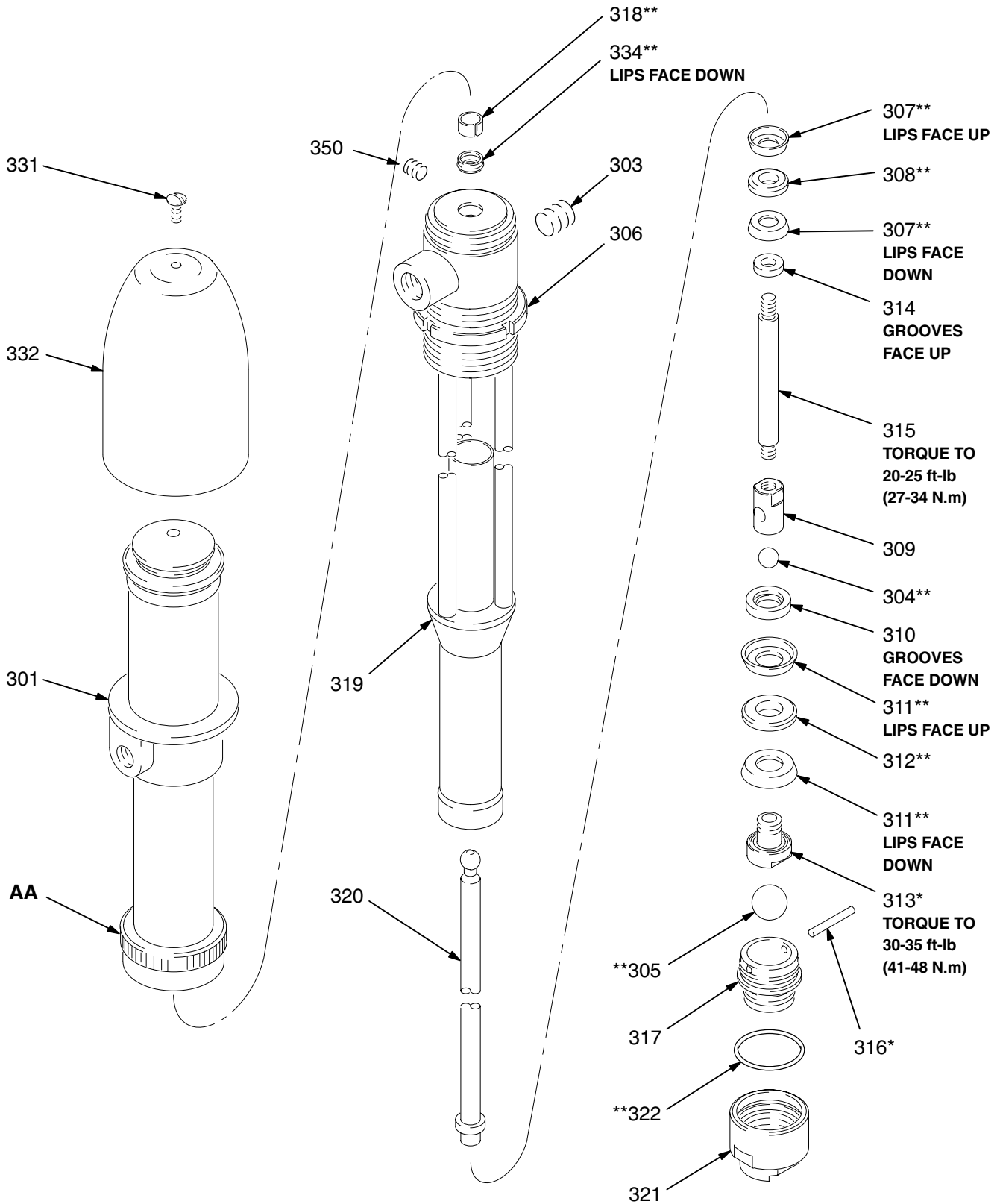

Pump Parts

Model 223954, Series B Stainless Steel, PTFE Packed

Ref. No.	Part No.	Description	Qty.	Ref. No.	Part No.	Description	Qty.
301	223953	AIR MOTOR; See 307851 for parts	1	318	166564**	. BEARING, connecting rod; filled PTFE	1
302	223955	DISPLACEMENT PUMP ASSY Series B Includes items 303-322; 334	1	319	223956	. FRAME, displacement pump; stainless steel	1
303	101748	. PLUG, pipe	1	320	223957	. ROD, upper connecting; 15.36" (390 mm) long; stainless steel	1
304	101750**	. BALL, piston valve	1	321	188037	. ADAPTER, intake; stainless steel	1
305	101917**	. BALL, intake valve	1	322	166612**	. O-RING; PTFE	1
306	161784	. NUT, bung lock; 2" npsm	1	331	101870	SCREW, shield retaining	1
307	161788**	. PACKING, cup; PTFE	2	332	186564	SHIELD, air motor	1
308	186647**	. BEARING, piston; PEEK	1	334	111791**	SEAL; glass-reinforced PTFE; with stainless steel spring	1
309	161791	. HOUSING, piston valve; stainless steel	1	350	104071	PLUG, pipe	1
310	161792	. WASHER, back-up; stainless steel	1		233583‡	TOOL, insert	1
311	161793**	. PACKING, cup; PTFE	2	* Recommended "tool box" spare parts. Keep on hand to reduce downtime.			
312	186648**	. BEARING, piston; PEEK	1	** Included in Repair Kit 224005.			
313	161795*	. BODY, piston; stainless steel	1	‡ This tool is ordered as a separate part item. It is located on the accessories page of this manual.			
314	162238	. WASHER, back-up; stainless steel	1	307 number in description refers to separate instruc- tion manual, supplied.			
315	186569	. ROD, lower connecting; 4.79" (122 mm) long; stainless steel	1	Conversion Kit 224017 is available to convert the pump to UHMWPE packings. Refer to the Accessories section.			
316	164250*	. PIN, ball stop; stainless steel	1				
317	166609	. HOUSING, intake valve; stainless steel	1				

Accessories

Must be purchased separately.

GROUNDING CLAMP 103538 GROUND WIRE 208950

25 ft (7.6 m) long,
12 gauge (1.5 mm²)

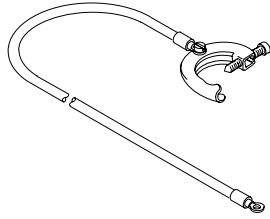

BLEED-TYPE MASTER AIR VALVE 300 psi (21 bar) MAXIMUM WORKING PRESSURE

107142 1/2 npt(m) inlet x 1/2 npt(f) outlet

Relieves air trapped in the air line between the pump air inlet and this valve when closed.

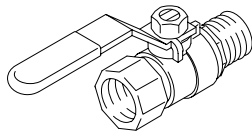

AIR LINE FILTER 250 psi (17.5 bar) MAXIMUM WORKING PRESSURE

106149 1/2 npt(f)
inlet and outlet

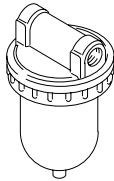

AIR LINE LUBRICATOR 250 psi (17.5 bar) MAXIMUM WORKING PRESSURE

214848 8 oz (0.24 liter)
bowl capacity. 1/2
npt(f) inlet and outlet

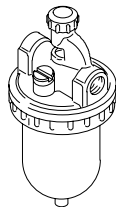

AIR LINE FILTER AND REGULATOR 202660 180 psi (13 bar) MAXIMUM WORKING PRESSURE

To regulate and filter compressed air supply to the gun. Includes gauge and two 1/4 npt(m) outlet valves, 50 micron filter element with 100 mesh inlet strainer. 1/2 npt(f) inlet. Flow rate is over 50 scfm (1.4 m³/min).

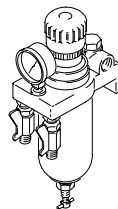

01355

AIR REGULATOR AND GAUGE 300 psi (21 bar) MAXIMUM WORKING PRESSURE

202156 0-200 psi (0-14 bar)
Regulated Pressure Range;
3/8 npt(f) inlet and outlet.

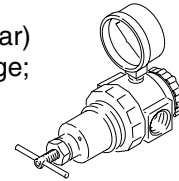

FLUID DRAIN VALVE 500 psi (35 bar) MAXIMUM WORKING PRESSURE

Relieves fluid pressure in the hose and gun.

208630 1/2 npt(m) x 3/8 npt(f); for
non-corrosive fluids; carbon steel
and PTFE

210071 3/8 npt(m) x 3/8 npt(f); for
corrosive fluids; stainless steel
and PTFE

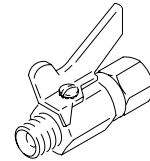

FLUID PRESSURE REGULATOR 250 psi (17.5 bar) MAXIMUM WORKING PRESSURE

Use on circulating line drops to regulate fluid pressure to each air spray gun or dispensing valve. 3/8 npsm(f) inlet; 3/8 npsm(m) and 3/8 npt(f) outlets.

203831 Carbon steel; 0-60 psi (0-4 bar) regulated fluid
pressure range; 2 gpm (7.6 liter/min) maximum flow
rate

209030 Stainless steel; 5-100 psi (0.4-7 bar) regulated
fluid pressure range; 3 gpm (11.3 liter/min) maximum
flow rate

203831 Carbon steel; 0-60 psi
(0-4 bar) regulated fluid pres-
sure range; 2 gpm (7.6 liter/min)
maximum flow rate

209030 Stainless steel; 5-100
psi (0.4-7 bar) regulated fluid
pressure range; 3 gpm (11.3
liter/min) maximum flow rate

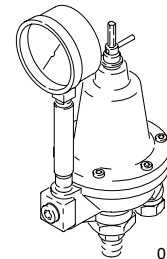

01356

Accessories

FLUID FILTER

300 psi (21 bar) MAXIMUM WORKING PRESSURE

For filtering paint in a circulating system. 6 gpm (22.7 liter/min) maximum volume. 3/4 npt(f) inlet and outlet.

213057 30 mesh

213058 60 mesh

213059 100 mesh

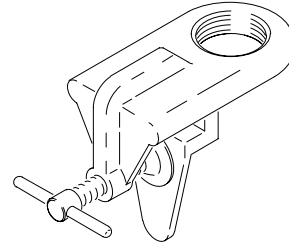
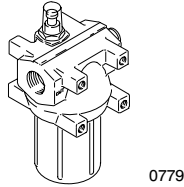

MOUNTING BRACKET 203987

For mounting Model 223954 to a wall.

PTFE FLUID HOSE 204865

1000 psi (70 bar) MAXIMUM WORKING PRESSURE

For connecting pump to fluid line.
6 ft (1.8 m); 1/2 in. (13 mm) ID; coupled 1/2 npt (mbe).

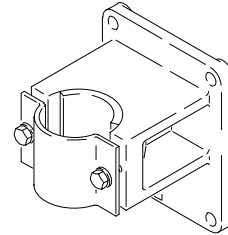

UHMWPE PACKING CONVERSION KIT 224017

Converts Model 226040 to use Ultra-High Molecular Weight Polyethylene cup packings. Includes cup packings, bearings, and instructions.

Tool 233583 (19" long)

For installation of seals.

STAINLESS STEEL PAIL COVER KIT 224302

For general purpose applications. Allows mounting of Model 223954 on a 5 gallon (19 liter) pail. Includes pail cover with agitator and return ports, return tube, mounting hardware, and assembly instructions.

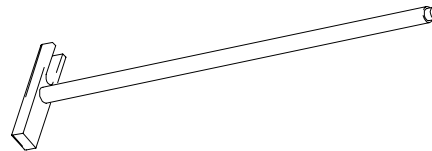

PAIL MOUNT KIT 224004

For rotary label applications only. Allows mounting of Model 223954 on a 5 gallon (19 liter) pail. Includes pail cover, mounting hardware, pump air inlet valve, and assembly instructions.

Tool 233582 (5-1/2" long)

For installation of seals.

PUMP CLAMP 204858

For mounting pump in open head drums or other containers. Corrosion-resistant.

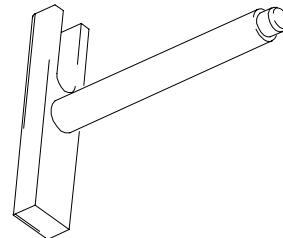

Dimensions

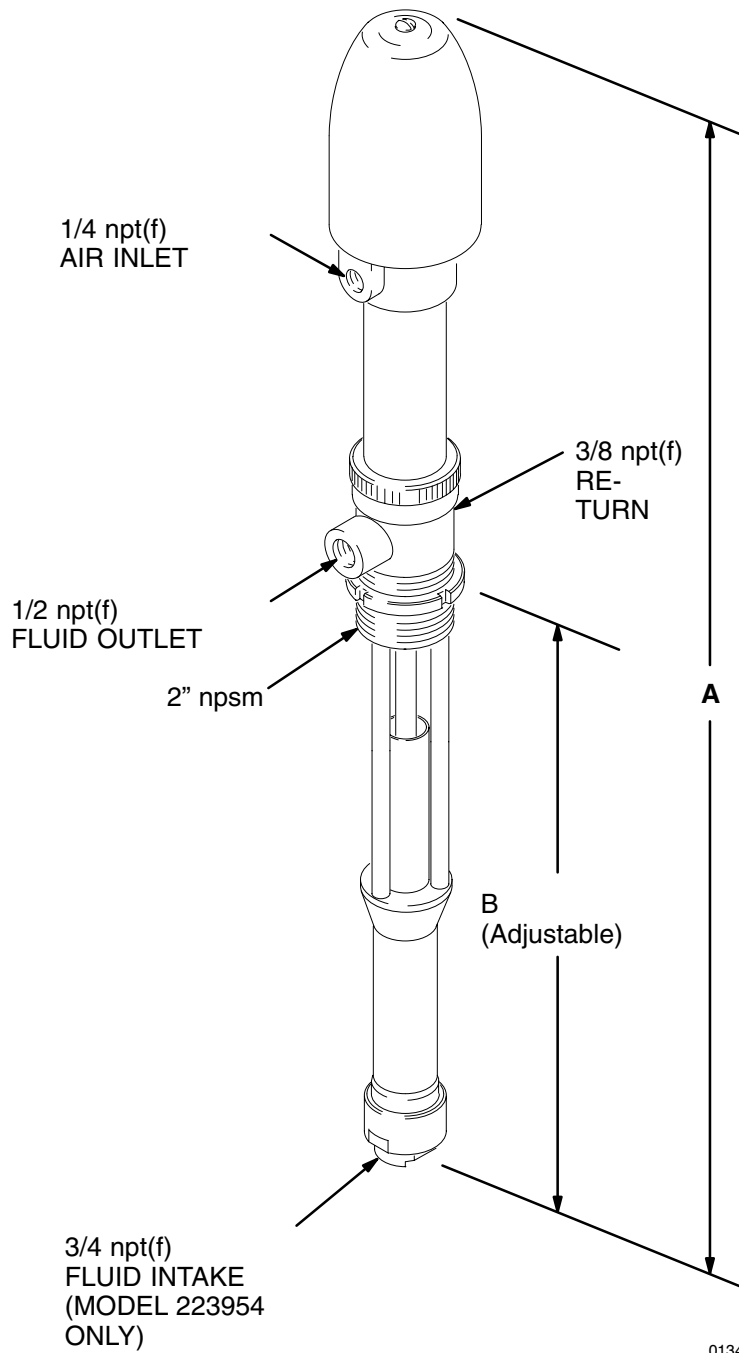

01347

Pump No.	A Overall Length	B Pump Length	Weight
226040	50.25 in (1276 mm)	32.375-33.875 in. (822-860 mm)	17 lb (7.7 kg)
223954	30.5 in. (775 mm)	13.70-14.10 in. (348-358 mm)	1.5 lb (5.2 kg)

Service Information

Listed below by the assembly changed are Old, New, and Added parts.

Assembly Changed	Status	Ref. No	Part No.	Name
204724 Displ. Pump to Series F	Old		161789	Bearing
	New	108	186647	Bearing
	Old		161794	Bearing
	New	112	186648	Bearing
	Added	134	111791	Seal
223955 Disp. Pump to Series B	Old		186563	Adapter
	New	321	188037	Adapter
	Added	334	111791	Seal

INTERCHANGEABILITY NOTE: New parts replace the Old parts listed directly above them.

Pump Model 226040 is advanced to Series G. Displacement Pump Model 204724 is advanced to Series F.

Pump Model 223954 is advanced to Series B. Displacement Pump Model 223955 is advanced to Series B.

Pump Model 206780 is obsolete and is removed from the manual.

Repair Kit 214730 is obsolete and is superseded by Repair Kit 224005.

Technical Data

Category	Data
Maximum fluid working pressure	360 psi (25 bar)
Air input pressure operating range	30-180 psi (2-12 bar)
Pump cycles per 1 gallon (3.8 liters)	40 (50 for Model 223954)
Maximum recommended pump speed for continuous operation	100 cycles per min
Air consumption	approx. 3 scfm (0.09 m ³ /min) at 1 gpm (3.8 liters/min) at 100 psi (7 bar) air pressure
Maximum Ambient temperature for T6 hazardous location use	120°F (50°C)
Maximum operating temperature of fluid pump	480°F (248°C) for non-hazardous location applications only
Maximum operating temperature of air motor	280°F (138°C) for non-hazardous location applications only
Wetted parts	Stainless Steel, PTFE, Polyetheretherketone (PEEK)

Technical Data

KEY: Fluid Outlet Pressure - Black Curves
Air Consumption - Gray Curves

NOTE: Pump may be operated continuously to shaded area (100 cpm). Area shown is for Model 226040 only. For Model 223954, 100 cpm line is at 1.5 gpm.

cycles/min (Model 223954)	50	100	125	150	200	250
cycles/min (Other Models)	40	80	100	120	160	200

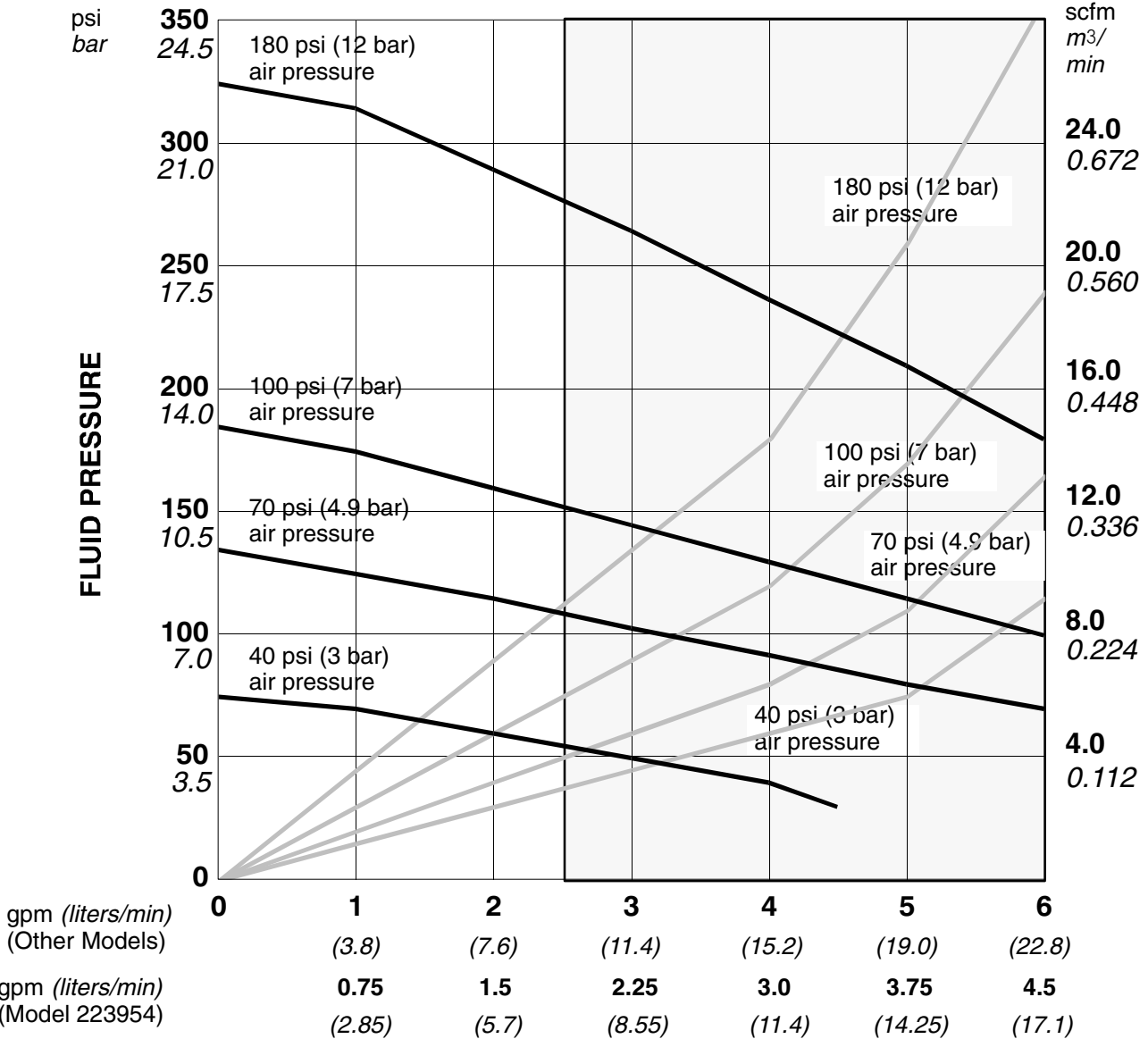

FLUID FLOW (TEST FLUID: NO. 10 WEIGHT OIL)

To find Fluid Outlet Pressure (psi/bar) at a specific fluid flow (gpm/lpm) and operating air pressure (psi/bar):

1. Locate desired flow along bottom of chart.
2. Follow vertical line up to intersection with selected fluid outlet pressure curve (black). Follow left to scale to read fluid outlet pressure.

To find Pump Air Consumption (scfm or m³/min) at a specific fluid flow (gpm/lpm) and air pressure (psi/bar):

1. Locate desired flow along bottom of chart.
2. Read vertical line up to intersection with selected air consumption curve (gray). Follow right to scale to read air consumption.

Graco Standard Warranty

Graco warrants all equipment manufactured by Graco and bearing its name to be free from defects in material and workmanship on the date of sale to the original purchaser for use. With the exception of any special, extended, or limited warranty published by Graco, Graco will, for a period of twelve months from the date of sale, repair or replace any part of the equipment determined by Graco to be defective. This warranty applies only when the equipment is installed, operated and maintained in accordance with Graco's written recommendations.

This warranty does not cover, and Graco shall not be liable for general wear and tear, or any malfunction, damage or wear caused by faulty installation, misapplication, abrasion, corrosion, inadequate or improper maintenance, negligence, accident, tampering, or substitution of non-Graco component parts. Nor shall Graco be liable for malfunction, damage or wear caused by the incompatibility of Graco equipment with structures, accessories, equipment or materials not supplied by Graco, or the improper design, manufacture, installation, operation or maintenance of structures, accessories, equipment or materials not supplied by Graco.

This warranty is conditioned upon the prepaid return of the equipment claimed to be defective to an authorized Graco distributor for verification of the claimed defect. If the claimed defect is verified, Graco will repair or replace free of charge any defective parts. The equipment will be returned to the original purchaser transportation prepaid. If inspection of the equipment does not disclose any defect in material or workmanship, repairs will be made at a reasonable charge, which charges may include the costs of parts, labor, and transportation.

THIS WARRANTY IS EXCLUSIVE, AND IS IN LIEU OF ANY OTHER WARRANTIES, EXPRESS OR IMPLIED, INCLUDING BUT NOT LIMITED TO WARRANTY OF MERCHANTABILITY OR WARRANTY OF FITNESS FOR A PARTICULAR PURPOSE.

Graco's sole obligation and buyer's sole remedy for any breach of warranty shall be as set forth above. The buyer agrees that no other remedy (including, but not limited to, incidental or consequential damages for lost profits, lost sales, injury to person or property, or any other incidental or consequential loss) shall be available. Any action for breach of warranty must be brought within two (2) years of the date of sale.

Graco makes no warranty, and disclaims all implied warranties of merchantability and fitness for a particular purpose in connection with accessories, equipment, materials or components sold but not manufactured by Graco. These items sold, but not manufactured by Graco (such as electric motors, switches, hose, etc.), are subject to the warranty, if any, of their manufacturer. Graco will provide purchaser with reasonable assistance in making any claim for breach of these warranties.

In no event will Graco be liable for indirect, incidental, special or consequential damages resulting from Graco supplying equipment hereunder, or the furnishing, performance, or use of any products or other goods sold hereto, whether due to a breach of contract, breach of warranty, the negligence of Graco, or otherwise.

FOR GRACO CANADA CUSTOMERS

The parties acknowledge that they have required that the present document, as well as all documents, notices and legal proceedings entered into, given or instituted pursuant hereto or relating directly or indirectly hereto, be drawn up in English. Les parties reconnaissent avoir convenu que la rédaction du présente document sera en Anglais, ainsi que tous documents, avis et procédures judiciaires exécutés, donnés ou intentés à la suite de ou en rapport, directement ou indirectement, avec les procédures concernées.

Graco Information

TO PLACE AN ORDER, contact your Graco distributor, or call one of the following numbers to identify the distributor closest to you:

1-800-328-0211 Toll Free

612-623-6921

612-378-3505 Fax

All written and visual data contained in this document reflects the latest product information available at the time of publication. Graco reserves the right to make changes at any time without notice.

Sales Office: Minneapolis
International Offices: Belgium, Korea, Hong Kong, Japan

www.graco.com

PRINTED IN USA 307026 04/1970, Revised 05/2004