



Binks MACH 1SL HVLP SPRAY GUN

Mach 1SLA (Adjustable Fluid Inlet) & Mach 1SLV (Vitreous)

The Binks MACH 1SL HVLP Gun is a top quality high performance air spray gun . You only have to pick it up to feel the difference. Its superbly balanced forged aluminum body offers the operator extra comfort and control. All of the gun's components are machined and finished to exacting tolerances and only the best materials are used, ensuring years of peak efficiency.

The MACH 1SL HVLP airspray gun has special nozzles and modifications that allow it to operate at high transfer efficiencies in compliance with the "California South Coast Air Quality Management District" regulations as a "high volume, low pressure" airspray gun.

The air inlet passage in the gun body incorporates a venturi which limits air-flow. High pressure, low volume airflow is converted to high volume, low pressure at this point. Special air and fluid nozzles enable the gun to atomize fluid at low air pressures and velocities, creating the "soft spray" effect for high transfer efficiencies.

To obtain optimum performance from your new MACH 1SL HVLP airspray gun, read all instructions carefully.

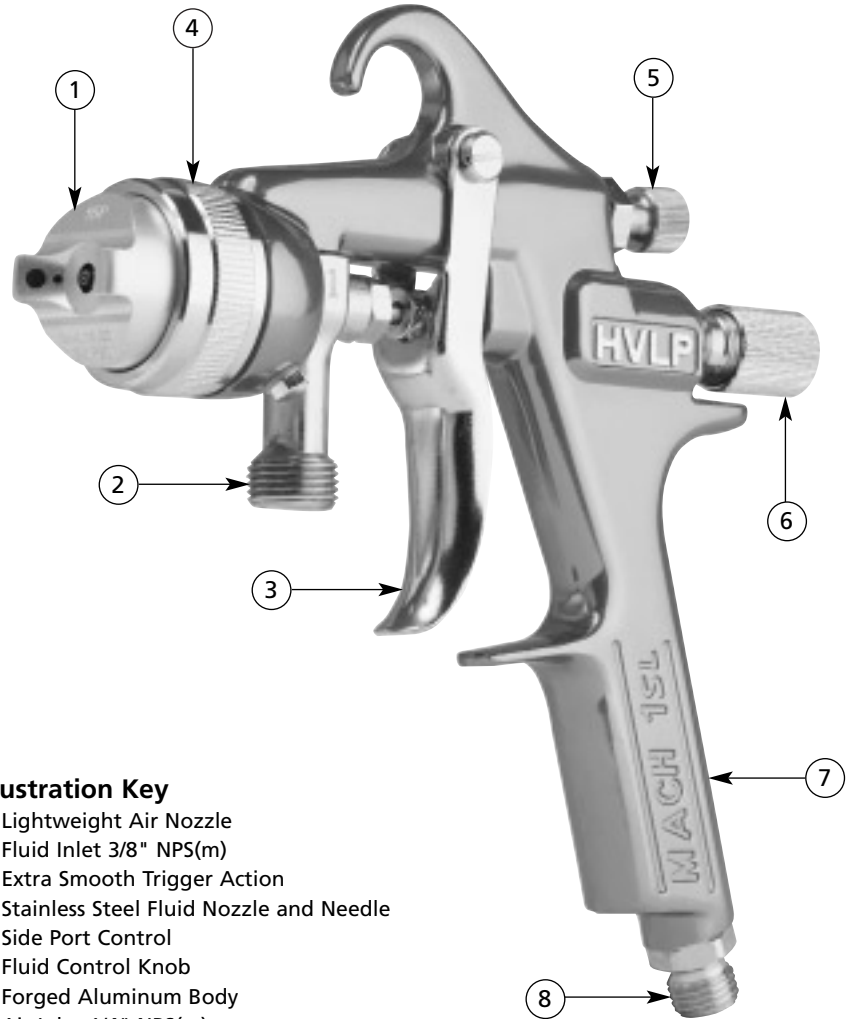

Illustration Key

1. Lightweight Air Nozzle
2. Fluid Inlet 3/8" NPS(m)
3. Extra Smooth Trigger Action
4. Stainless Steel Fluid Nozzle and Needle
5. Side Port Control
6. Fluid Control Knob
7. Forged Aluminum Body
8. Air Inlet 1/4" NPS(m)

NOTE

IMPORTANT REGULATORY NOTE regarding the use of this product appears on page 8.

Package Contents

Please note that your Binks MACH 1SL HVLP airspray gun package was shipped with the following contents. If anything in the following list is missing, call 1-800-99-BINKS for a prompt shipment to you of the missing item.

- | | |
|---|---------------------------|
| 1 | MACH 1SL Spray Gun |
| 1 | Part Sheet 2665 |
| 1 | Gunners Mate |
| 1 | Gun Brush |

Replaces	Part
Part Sheet	Sheet
77-2665R-3	77-2665R-4

TYPES OF INSTALLATION

CONNECTING GUN TO "PRESSURE ASSISTED" 1 QT. CUP (Figure 1)

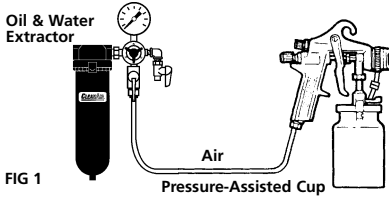

FIG 1

The stainless steel pressure-assisted 1-quart cup, 80-272, utilizes a low pressure air bleed port on the gun head to slightly pressurize the cup and provide fluid flow to the nozzle. A check valve prevents the cup from depressurizing when the gun trigger is released and airflow stops.

To connect the gun to the cup, remove the plug (35) in the gun head and install the hose barb fitting provided with cup assembly. Attach cup assembly to 3/8" NPS fluid inlet connection and firmly tighten. The siphon tube should be angled toward the front of the gun, i.e. under the nozzles, and the pressure hose in the cup lid positioned to the left of the trigger. Connect check valve assembly hose from barb fitting on gun head to check valve inlet fitting on cup cover. Make sure the check valve is connected so the air comes from the gun, through the check valve, into the cup.

Air pressure for atomization is regulated at the extractor. The flow of the fluid is adjusted by the fluid valve control knob on gun, viscosity of paint and air pressure.

PRESSURE CUP HOOKUP (Figure 2)

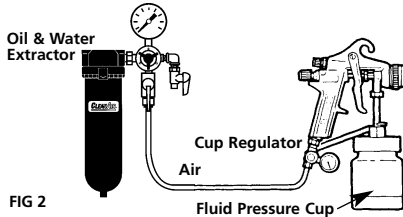

FIG 2

For fine finishing with limited spraying. Air pressure for atomization is regulated at extractor; fluid pressure at cup regulator. pressure cup is also available less regulator.

PRESSURE TANK HOOKUP (Figure 3)

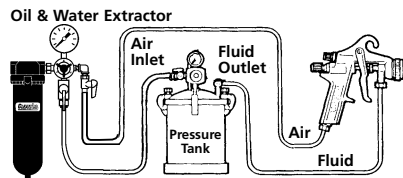

FIG 3

For medium production spraying (single regulator). Air pressure for atomization is regulated at extractor, fluid pressure at tank regulator.

PRESSURE TANK WITH 2 REGULATORS (Figure 4)

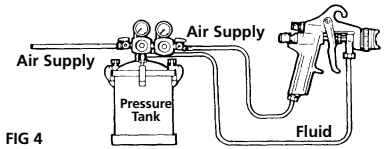

FIG 4

The pressure to the tank is regulated by the first regulator. The pressure for atomization is regulated by the second regulator.

PRESSURE CIRCULATING HOOKUP (Figure 5)

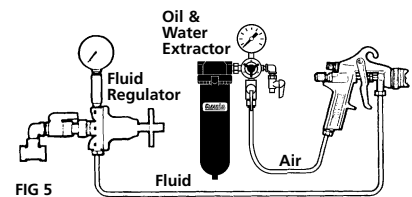

FIG 5

For heavy production spraying. Air pressure atomization regulated at extractor. Fluid pressure regulated at fluid regulator.

AIR PRESSURE

Atomizing pressure must be set properly to allow for the drop in air pressure between the regulator and the spray gun.

With 60 psi applied at air supply



5/16"

Cross section view showing comparison of inside hose diameters (actual size). 60 lbs. regulated pressure



1/4"

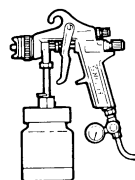

Only 34 PSI at gun inlet

25 feet of 1/4" I.D. hose causes a drop of 26 PSI between the air supply and the gun.

(NOT RECOMMENDED)

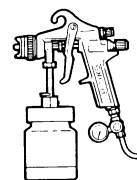

48 PSI at gun inlet

25 feet of 5/16" I.D. hose causes a drop of 12 PSI between the air supply and the gun. For this reason Binks recommends the use of 5/16" hose.

(RECOMMENDED)

Binks oil and water extractor is important.

Achieving a fine spray finish without the use of a good oil and water extractor is virtually impossible.

A Binks regulator/extractor serves a double purpose. It eliminates blistering and spotting by keeping air free of oil and water, and it gives precise air pressure control at the gun.

Binks recommends using the HFRL-508 oil and water extractor/regulator. See your local distributor for models.

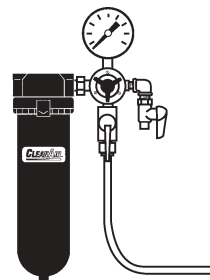

OPERATION AND MAINTENANCE FOR MACH 1SL HVLP SPRAY GUN

Your new MACH 1SL HVLP spray gun is exceptionally rugged in construction and is built to stand up under hard, continuous use. However, like any other fine precision instrument, its most efficient operation depends on a knowledge of its construction, operation and maintenance. Properly handled and cared for, it will produce beautiful, uniform finishing results long after other spray guns have worn out.

SET-UP FOR SPRAYING

Connecting Gun To Air Hose

Air should be supplied by a suitable length of 5/16" diameter air hose fitted with a 1/4" NPS connection at gun end. For hose lengths over 50', use 3/8" diameter hose.

Connecting Gun To Fluid Hose

Fluid should be supplied by a suitable length of 3/8" diameter fluid hose fitted with a 3/8" NPS(f) connection at gun end. 1/4" diameter hose is recommended for use with low viscosity fluids. (Fluid hoses of different composition are available for special fluids.)

SPRAY GUN CLEANING INSTRUCTIONS

In certain states it is now against the law to spray solvents containing Volatile Organic Compounds (VOC)'s into the atmosphere when cleaning a spray gun.

In order to comply with these air quality laws Binks recommends one of the following two methods to clean your spray finishing equipment:

1. Spray solvent through the gun into a closed system. An enclosed unit or spray gun cleaning station condenses solvent vapors back into liquid form which prevents escape of VOC's into the atmosphere.
2. Place spray gun in a washer type cleaner. This system must totally enclose the spray gun, cups, nozzles and other parts during washing, rinsing and draining cycles. This type of unit must be able to flush solvent through the gun without releasing any VOC vapors into the atmosphere.

Additionally, open containers for storage or disposal of solvent or solvent-containing cloth or paper used for surface preparation and clean-up may not be used. All containers shall be nonabsorbent.

Pointers On Cleaning

When used with 1-quart cup relieve pressure in the cup. Then unscrew, empty and carefully rinse cup out with thinners.

Place clean thinners in the cup and spray this through the gun until it is clean.

Blow air through gun to dry it.

When Used With Pressure Container

Shut off air supply to container and release the pressure on the container.

Hold a piece of cloth wadded in the hand over the gun nozzle (3) and pull the trigger. The air will back up through the fluid nozzle and force the fluid out of the Hose into the container. Empty container.

Put enough thinner into the container to wash hose and gun thoroughly and spray this through the gun until it is clean. Then blow out the fluid hose to dry it and remove all traces of fluid by attaching it to the air line.

When used with Paint Circulating System

Shut off fluid supply and remove fluid hose from gun. Clean as gun used with siphon cup or pressure container or connect quick release on paint line solvent line. To ensure a clean air supply to your spray gun, use Binks oil and water extractor. See your Binks distributor for the correct model.

GENERAL MAINTENANCE

To Replace Air Valve and Spindle Assembly

Remove fluid control knob (19), spring (14) and needle assembly (16). Unscrew housing (15) and remove spindle assembly (13) with springs (12 & 14), seal retainers (11) and o-rings (10). Lubricate new o-rings with Binks Gunner's Mate. In the absence of Gunner's Mate, a sparing amount of petroleum jelly can be used. If too much petroleum jelly is used, the air

passages will carry it into the finished product.

Assemble components using fluid needle. Place this assembly along with housing (15) into gun body and screw into position. Remove fluid needle and tighten housing.

To Replace Cartridge Assembly

Remove fluid control knob (19), spring (14) and remove needle assembly (16). Pull back trigger (23) and remove seal cartridge assembly (25) from fluid inlet (24). Remove and discard plastic packing pin in new seal cartridge assembly. Attach seal cartridge assembly to fluid inlet. Assemble needle assembly (16), spring (14) and fluid control knob (19) to gun.

Adjustment of Material Needle

The needle assembly is adjustable for length by means of the needle, needle cap, and needle locknut. These should be adjusted so that when the trigger assembly is in contact with the spindle assembly (13), a movement of the spindle assembly of 1/16" is required before the material needle moves.

Under no circumstances should the material valve open before the air valve.

CAUTION

All parts on a spray gun should be screwed in hand tight at first; this will avoid the possibility of cross threading the parts. If the parts cannot be turned by hand easily, make sure you have the correct parts, unscrew, realign, and try again. NEVER use undue force in mating parts.

Binks MACH 1SL, MACH 1SLA (ADJUSTABLE FLUID INLET), AND MACH 1SLV

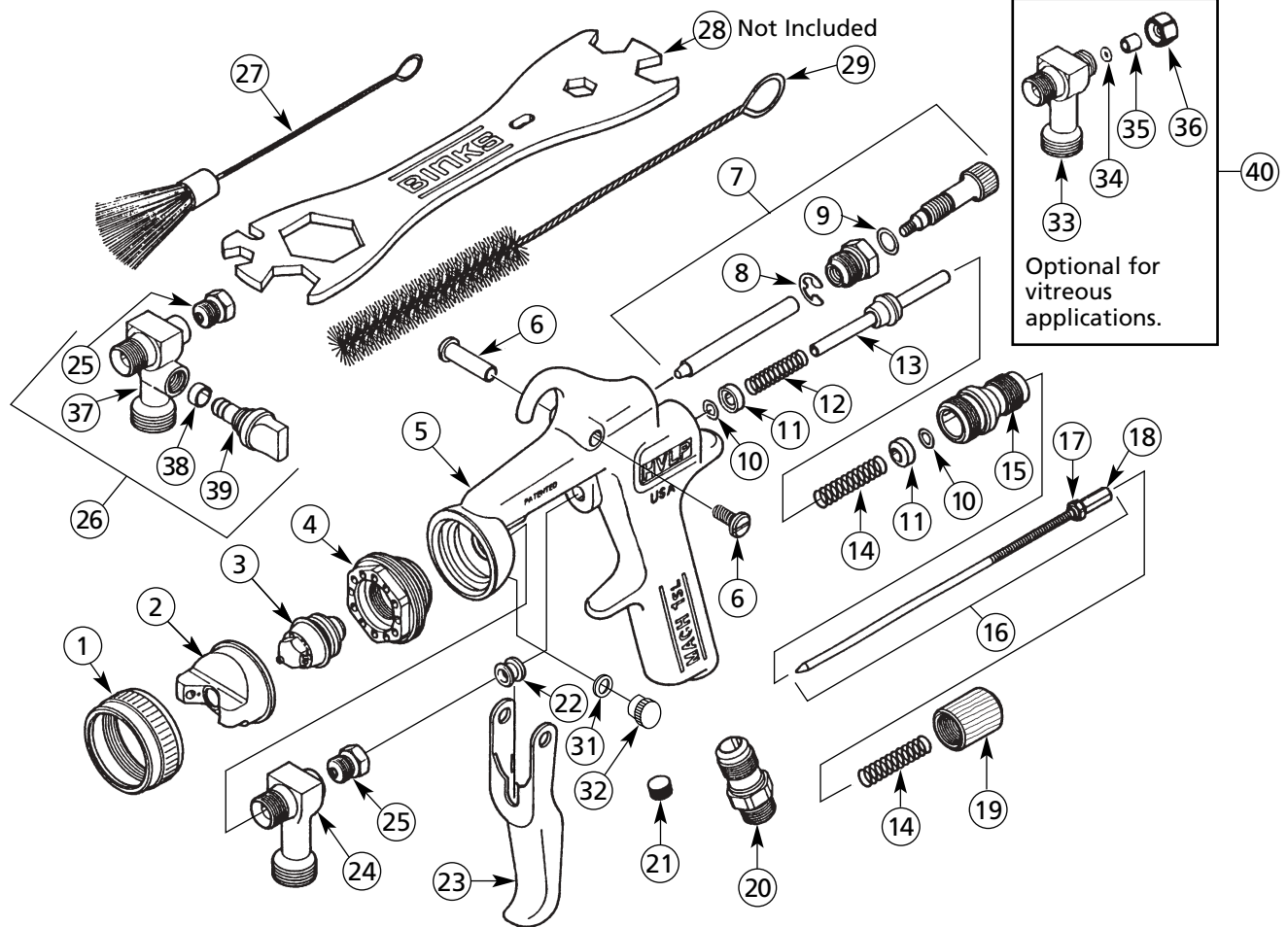

PARTS LIST

(When ordering, please specify Part No.)

ITEM NO.	PART NO.	DESCRIPTION	QTY.	ITEM NO.	PART NO.	DESCRIPTION	QTY.
1	54-3531	RETAINER RING (Metal)	1	25	54-4370▲	SEAL CARTRIDGE ASSEMBLY (Mach 1SL and Mach 1SLA)	1
2	*	AIR NOZZLE	1	26	54-4330	ADJUSTABLE FLUID INLET ASSEMBLY (Mach 1SLA)	1
3	*	FLUID NOZZLE	1	27	54-4133●	GUN BRUSH (Optional)	1
4	54-3543	HEAD INSERT	1	28	54-3918●	WRENCH (Not Included - Optional)	
5	54-4339	GUN BODY ASSEMBLY	1	29	82-469	GUN BRUSH	1
6	54-3919	TRIGGER STUD AND SCREW KIT	1	30	54-4440●	QUICK CHANGE SIDE PORT CONTROL ASSEMBLY (Optional - Not Shown)	
7	54-4343	SIDE PORT CONTROL ASSEMBLY	1	31	54-3925	GASKET	1
8	54-3511▲	RETAINING RING	1	32	54-3928	PLUG	1
9	20-6160▲	O-RING	1	33	54-4541●†	FLUID INLET (Mach 1SLV)	1
10	20-4615▲	O-RING	2	34	20-2227●†	O-RING (Mach 1SLV)	1
11	54-3515	SEAL RETAINER	2	35	54-4531●†	SPACER (Mach 1SLV)	1
12	54-3520▲*	SPRING (Yellow)	1	36	54-4542●†	NUT ASSEMBLY (Mach 1SLV)	1
13	54-3512▲	SPINDLE ASSEMBLY	1		54-3871▲	GUNNERS MATE 3cc (Not Shown)	1
14	54-3518▲*	SPRING (Blue)	2	37	54-4333	FLUID INLET	1
15	54-3541	HOUSING	1	38	54-4337	PACKING SEAL	1
16	*	NEEDLE ASSEMBLY	1	39	54-4332	SEAL CARTRIDGE ASSEMBLY	1
17	54-3604	NEEDLE ASSEMBLY LOCKNUT	1	40	54-4540●	FLUID INLET ASSEMBLY (Mach 1SLV)	1
18	54-3603	NEEDLE CAP	1				
19	54-3606	FLUID VALVE CONTROL KNOB	1				
20	54-768	AIR CONNECTION	1				
21	20-2287	PLUG 1/8" NPT	1				
22	54-3513	VALVE SPINDLE CAP	1				
23	54-4360	TRIGGER	1				
24	54-3742	FLUID INLET (Mach 1SL)	1				

* See Air and Fluid Nozzle Chart on page 5.

▲ Included in 54-4278 Spare Parts Kit.

● Optional - Order separately.

† For vitreous set-up.

FLUID NOZZLES

STANDARD FLUID NOZZLES

FLUID	FLUID NOZZLE NO.	APPLICABLE AIR NOZZLE	FLUID NEEDLE
ULTRA LIGHT / Reduced Flow	89 (.020" Dia.) 0.5 mm	90P*** 95P, 97P, 92P* 95AP, 97AP** 93P, 94P	SEE NOTE
VERY LIGHT / Reduced Flow	90 (.030" Dia.) 0.8 mm		
LIGHT: less than 15 to 20 seconds in a Zahn 2 Cup, e.g., stains, varnishes, thin lacquers, automotive refinishing fluids.	91 (.040" Dia.) 1.0 mm 92 (.046" Dia.) 1.2 mm		
MEDIUM: 20 to 60 seconds in a ZAHN 2 Cup, e.g., general industrial coatings.	94 (.055" Dia.) 1.4 mm		
HEAVY: greater than 60 seconds in a Zahn 2 Cup.	97 (.070" Dia.) 1.7 mm		

NOTE: Use stainless steel fluid needle (54-4382) for all above nozzles. Optional nylon-tipped stainless steel fluid needle (54-4381) is also available. Binks needles AB and AB55 (54-3941 & 54-3940) may be used, but require readjustment of the needle cap and locknut position.

GS FLUID NOZZLES

FLUID	FLUID NOZZLE NO.	APPLICABLE AIR NOZZLE	FLUID NEEDLE
LIGHT/MEDIUM: less than 15 to 20 seconds in a Zahn 2 Cup, e.g., stains, varnishes, thin lacquers, automotive refinishing materials.	92GS (.046" Dia.) 1.2 mm 93GS (.052" Dia.) 1.3 mm 94GS (.055" Dia.) 1.4 mm	96G ■	SEE NOTE 54-4547
MEDIUM: 20 to 60 seconds in a ZAHN 2 Cup, e.g., general industrial coatings.	95GS (.059" Dia.) 1.5 mm 96GS (.063" Dia.) 1.6 mm 97GS (.070" Dia.) 1.7 mm		

NOTE: Optimum setup for clear coat spray is 92GS Fluid Nozzle x 96G Air Nozzle Assembly.

OPTIONAL GS FLUID NOZZLE SIZES

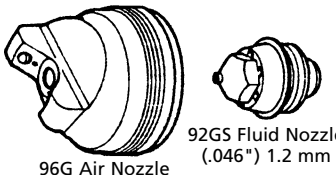

NEEDLE ADJUSTMENT LENGTH
(See adjustment guide at right.)

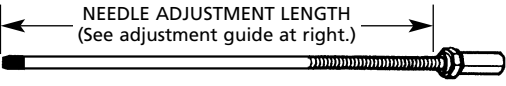

54-4547 CSS Needle
(Needs to be adjusted to fit your gun.
See adjustment guide at right.)

Needle Adjustment Guide

Model	Length
MACH 1	5.8 in.
MACH 1SL	5.7 in.
M1-Gravity	5.5 in.

Nozzle	Diameter	
	Inches	mm
92GS	.046	1.2
93GS	.051	1.3
94GS	.055	1.4
96GS	.063	1.6

Example: 93GS Fluid Nozzle, 96G Air Nozzle & 54-4547 Needle.

SPECIAL PURPOSE NOZZLES

TYPICAL APPLICATION	FLUID NOZZLE NO.	APPLICABLE AIR NOZZLE	COMPATIBLE FLUID NEEDLE
VERY HEAVY FLUIDS: Block Fillers, Texture Coatings, Fire Retardants, Road Marking Paint, Bitumastics, Adhesives, Cellular Plastics, Underbody & Vitreous Coatings, Special Applications	94VT (.052") 1.3mm Carbide Tip	94P, 97P	54-4383 VT
	901VT (.066") 1.6 mm Carbide Tip	905P	54-4384 VT
	903 (.079") 2.0 mm		54-4382/54-4381
	905 (.089") 2.3 mm		54-4382/54-4381
	905VT (.088") 2.3 mm Carbide Tip		54-4385 VT
	906 (.100") 2.5 mm		54-4382/54-4381
	909 (.111") 2.8 mm		54-4382/54-4381
	909VT (.112") 2.8 mm Carbide Tip		54-4386
FEATHERING For applications requiring more gradual fluid valve opening for metering control of fluid flow with trigger	90F (.030") 0.8 mm		94P
	91F (.040") 1.0 mm	97P	54-4388
	92F (.046") 1.2 mm	91P, 92P*	54-4389
	94F (.055") 1.4 mm	95AP**●	54-4390
	97F (.070") 1.7 mm	97AP**●	54-4391
SIPHON FEED-FINE FINISH Light to medium fluids Auto body spot repairs Medium to heavy fluids Auto body overall finishing	94s (.055") 1.4 mm	95AS●	54-4390
	97s (.070") 1.7 mm		54-4391

* 92P Low Volume Nozzle for general industrial and automotive fine finish.

** 95AP High Solids Nozzle for hard to atomize coatings and higher flow rates. 97AP same as 95AP, but for wider fan if needed.

*** 90P Low Volume Nozzle, 1 1/2 H.P. Compressor or bigger - (6 C.F.M) required.

● 95AP, 95AS and 97AP Air Nozzles do not require separate Retainer Ring.

■ Improves atomization, breaks-up high solid material easier, provides better finish at lower pressures and reduces orange-peel dramatically. 54-4547 needle must be used in conjunction with the GS fluid nozzle and 96G air nozzle.

AIR NOZZLES

AIR PRESSURE RECOMMENDATIONS

TYPE OF FLUID	ATOMIZING PSI	FLUID PRESSURE RANGE- PSI
Primer/surfaces	3-4	1-4
Light Stains, Inks	4-5	1-5
Acrylic Enamels	6-7	2-7
Lacquers	7-8	2-8
Low VOC, Urethanes	8-10	2-10

HVLP AIR NOZZLES 95P, 97P, 95AS, 95AP, 97AP, 905P

NOZZLE ATOMIZING PSI	NOZZLE AIRFLOW SCFM	SIDE PORT CONTROL	
		GUN INLET PSI	REGULATOR* PSI
3.0	11.0	20.0	27.0
5.0	15.7	30.0	40.0
7.0	17.5	38.0	50.0
9.0	19.6	45.0	58.0
10.0	22.5	50.0	64.0

HVLP AIR NOZZLE 90P

NOZZLE ATOMIZING PSI	NOZZLE AIRFLOW SCFM	SIDE PORT CONTROL	
		GUN INLET PSI	
3.0	4.0	5.0	
5.0	4.5	7.0	
7.0	5.0	10.0	
9.0	5.5	12.0	
10.0	6.0	15.0	

HVLP AIR NOZZLE 92P

NOZZLE ATOMIZING PSI	NOZZLE AIRFLOW SCFM	SIDE PORT CONTROL	
		GUN INLET PSI	REGULATOR* PSI
3.0	4.5	6.0	9.0
5.0	6.0	8.5	10.0
7.0	6.8	11.0	14.0
9.0	7.5	13.5	18.0
10.0	8.0	15.0	19.0

HVLP AIR NOZZLE 93P

NOZZLE ATOMIZING PSI	NOZZLE AIRFLOW SCFM	SIDE PORT CONTROL	
		GUN INLET PSI	REGULATOR* PSI
3.0	5.5	8.0	10.0
5.0	7.0	11.5	14.0
7.0	8.0	14.5	18.0
9.0	9.5	17.0	22.5
10.0	10.0	18.0	24.0

HVLP AIR NOZZLE* 94P

Nozzle Atomizing PSI	Nozzle AIR FLOW SCFM	Side Port Control GUN INLET PSI
3.0	7.0	14.0
5.0	9.0	21.0
7.0	11.0	27.0
9.0	12.0	30.0
10.0	13.0	33.0

HOW TO USE THE NOZZLE SELECTION CHART

HVLP AIR NOZZLES

Maximum recommended nozzle atomizing pressure is 10 psi. The 95P and 905P air nozzles are most suitable for conventional materials. Use of very low fluid delivery rates with these nozzles will produce a narrower than normal fan pattern.

Use the 97P air nozzle for heavy bodied, high solids materials and low fluid rates with conventional materials. High flow rates with light bodied materials may result in some minor "smoking" or fluid build-up on the face of these nozzles.

*** NOTE:** Regulator pressures are based on 25' of 5/16" diameter hose in good condition without quick-disconnects or other restrictive fittings. Use the air nozzle test gauge accessory to confirm the atomizing/regulator pressure relationship for your actual air supply set-up. These recommendations are for "typical" or "average" fluids, and are intended to serve as a starting point. Adjust as necessary for your specific application.

SPRAY TECHNIQUE

The first requirement for a good resultant finish is the proper handling of the gun. The gun should be held perpendicular to the surface being covered and moved parallel with it. The stroke should be started before the trigger is pulled and the trigger should be released before the stroke is ended. This gives accurate control of the gun and fluid.

The distance between gun and surface should be 6 to 12 inches depending on fluid and atomizing pressure. The fluid deposited should always be even and wet. Lap each stroke over the preceding stroke to obtain a uniform finish.

NOTE

To reduce overspray and obtain maximum efficiency always spray with the lowest possible atomizing air pressure.

GENERAL SPRAY INSTRUCTIONS

To reduce overspray and obtain maximum efficiency, always spray with the lowest possible fluid/air pressure that produces an acceptable spray pattern.

NOTE

Excessive atomizing air pressures can increase overspray, reduce transfer efficiency, and with some materials, result in poor finish quality from dry spray. Atomizing air pressures should not exceed 10 psi. See table on page 6, diagram on page 2 and regulatory note on page 8.

For best results, use 3 to 6 psi fluid pressure. Higher than 6 psi fluid pressure may be required for heavy-bodied materials. Low fluid pressures will produce a narrower than normal spray pattern. Generally use 30-35 psi air at gun inlet (see page 6). Unusually heavy, difficult to atomize fluids may require up to 50 psi air at gun inlet.

CONTROLLING THE FAN SPRAY

The fan spray is controlled by means of the side port control assembly (7). Turning this control clockwise until it is closed will give a round spray; turning it counterclockwise will widen the spray into a fan shape. The fan spray can be turned anywhere through 360° by positioning the air nozzle (2) relative to the gun. To accomplish this, loosen retaining ring (1), position nozzle (2), then tighten retaining ring (1).

CONTROLLING THE FLUID FLOW

When used with a pressure assisted cup, an increase in air pressure will increase the rate of flow. When fed from a pressure supply, an increase in the fluid pressure will increase the rate of flow. Correct fluid nozzle size should be selected for correct fluid flow rate. The fluid control knob (19) may be used to restrict the (3) fluid nozzle opening and reduce the fluid flow as necessary.

AIR NOZZLE, FLUID NOZZLE, NEEDLE ASSEMBLY

1. All nozzles and needles are precision made. They should be handled with care.
2. Except as described in "ADJUSTING THE NEEDLE ASSEMBLY", do not make any alterations in the gun. To do so could cause finishing difficulties.
3. To clean nozzles, soak them in solvent to dissolve any dried material, then blow them clean with air.
4. Do not probe any of the holes in the nozzles with metal instruments. If probing is necessary, use only a tool that is softer than brass.

ADJUSTING THE NEEDLE ASSEMBLY (16)

1. Remove the fluid control knob (19) and the blue spring (14).
2. Pull the needle assembly out approximately 1-1/4 inches.
3. Loosen the needle cap (18).
4. Screw the needle assembly locknut (17) out for more trigger movement, in for less trigger movement.
5. Adjust the needle assembly so that when the trigger (23) moves, the spindle assembly (13) moves 1/16 to 3/32 of an inch before the needle assembly moves.

CAUTION

Overtightening may damage the threads and make future adjustments difficult.

6. Tighten the needle cap.

TROUBLESHOOTING

Faulty Spray

A faulty spray pattern is often caused by improper cleaning resulting in dried materials around the fluid nozzle tip or in the air nozzle. Soak these parts in thinners to soften the dried material and remove with a brush or cloth.

CAUTION

NEVER USE METAL INSTRUMENTS TO CLEAN THE AIR OR FLUID NOZZLES. THESE PARTS ARE CAREFULLY MACHINED AND ANY DAMAGE TO THEM WILL CAUSE FAULTY SPRAY. If either the air nozzle (2) or fluid nozzle (3) are damaged, these parts must be replaced before perfect spray can be obtained.

Intermittent Spray

If the spray flutters, it is caused by one of the following faults:

1. Insufficient fluids available. Check supply and replenish if necessary.
2. Pressure vent tube from gun body to pressure assist cup is loose or leaking.
3. Check valve in pressure assist cup is stuck or blocked.
4. Pressure assist cup cover not sufficiently tight or cover gasket defective.
5. Insufficient fluid pressure from standard pressure pots.

OPERATING THE MACH 1SL HVLP SPRAY GUN

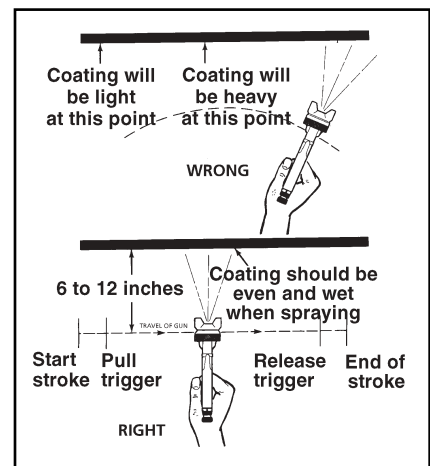

IMPORTANT REGULATORY NOTE

Some regulatory agencies prohibit the operation of HVLV spray guns above 10 psi nozzle atomizing pressure. Users subject to this type of regulation should not exceed 10 psi (50 psi gun inlet pressure). See *Air Pressure Recommendations*, page 6 and *General Spray Instructions*, page 4. It is recommended that the nozzle test gauge (see below) be used to confirm actual nozzle operating pressure.

It may also be a requirement of some regulatory agencies that users have this gauge nozzle available on site to verify that the gun is being operated within the limits of applicable rules.

Part Number	Description
54-3908*	900 SERIES
54-3935	95 and 97 SERIES, 95AP and 97AP
54-4078*	95AS and 97AS NOZZLES (Siphon)
54-4345*	90P NOZZLE
54-4356	93P NOZZLE
54-4066*	94P NOZZLE
54-4566	96G NOZZLE

*Available from Industrial Finishing distributors only.

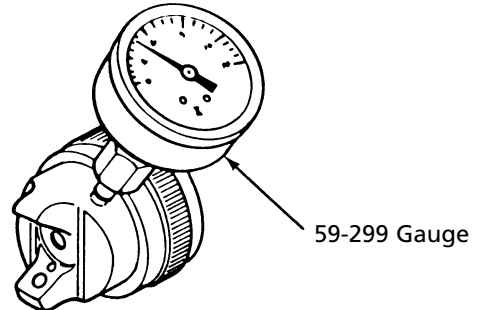

Sales and Service Through a Nationwide Network of Industrial Distributors.

Customer Service in USA / 1-800-992-4657
Technical Support in USA / 1-888-992-4657



195 Internationale Blvd.
Glendale Heights, IL 60139

77-2665R-4 Revisions: (P2) Updated diagrams to show new style extractor, added reference to recommended extractor HFRL-508; (P4) Revised diagram and Parts List; (P5) revised Fluid Nozzles chart; (P6) Removed references to #6 side port control; (P8) Updated list.

Part Sheet 77-2665R-4 Printed in USA 7/03, All Rights Reserved