

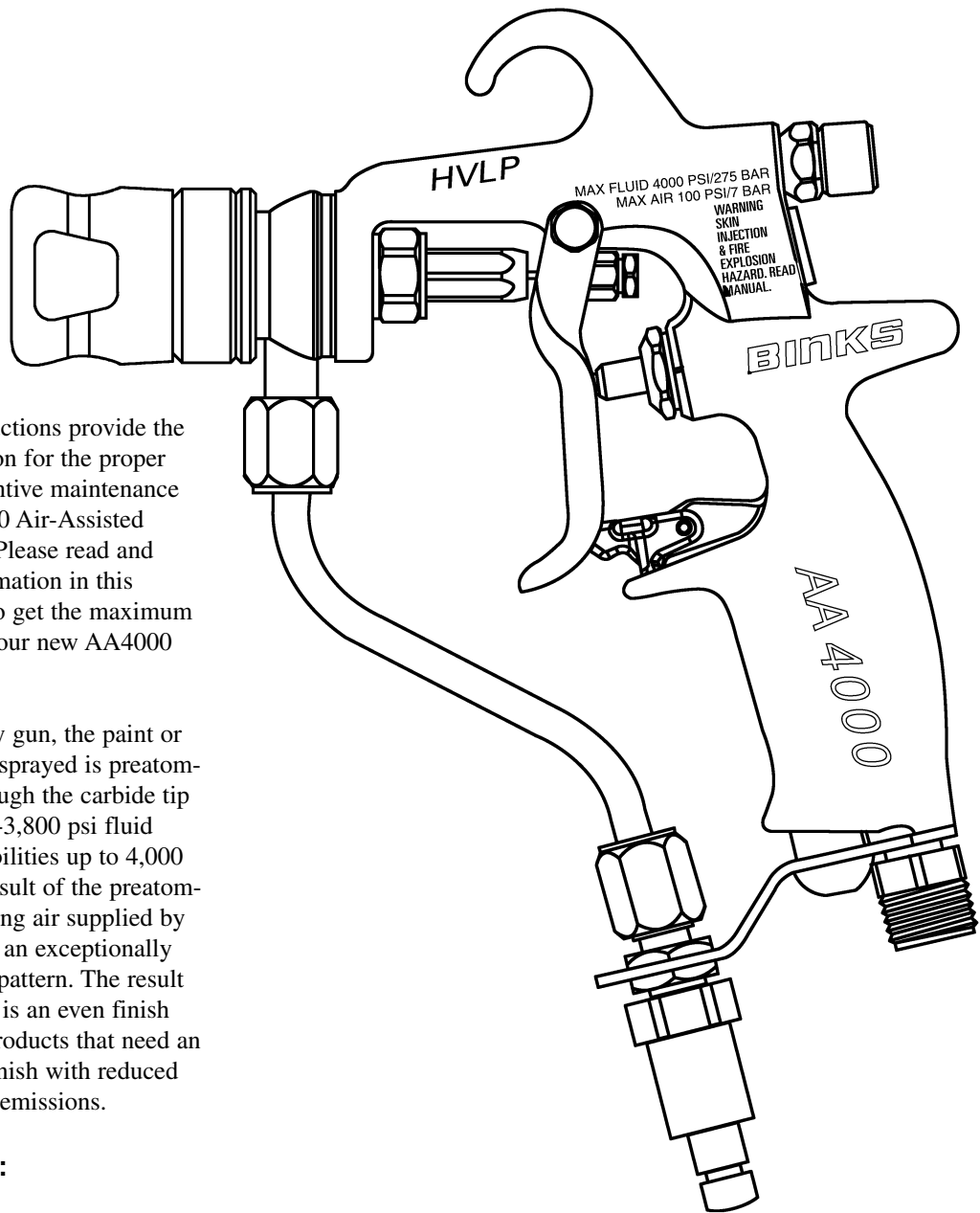

# AA4000 AIR-ASSISTED AIRLESS SPRAY GUN (WITH AA10HP AIR CAP AND FAN SIZE ADJUSTMENT FEATURE)



The following instructions provide the necessary information for the proper operation and preventive maintenance of the Binks AA4000 Air-Assisted Airless Spray Gun. Please read and understand all information in this document in order to get the maximum performance from your new AA4000 spray gun.

In the AA4000 spray gun, the paint or other material to be sprayed is preatomized and forced through the carbide tip by the typical 1,500-3,800 psi fluid pressure (with capabilities up to 4,000 psi/275 bar). As a result of the preatomizing, the final shaping air supplied by the air cap produces an exceptionally fine and even spray pattern. The result of this spray pattern is an even finish that lends itself to products that need an exceptionally fine finish with reduced overspray and VOC emissions.

## SPECIFICATIONS:

Maximum  
Fluid Pressure: 4000 psi/275 bar  
Maximum  
Air Pressure: 100 psi/6.8 bar  
Gun Body: Forged Aluminum  
Fluid Path: Stainless Steel  
Fluid  
Shut Off Type: Tungsten Carbide Seat standard  
(UHMW Seat optional)  
Fluid Inlet Size: 1/4" NPS(m) Thread  
Air Inlet Size: 1/8" NPT(m) x 1/4" NPS(m)  
D.M. Nipple  
Gun Weight: 16-oz.

Product shown is covered by U.S. patent No. 6,276,616.  
Foreign patents are issued or pending.

Replaces  
Part Sheet  
77-2839R-2

Part  
Sheet  
77-2839R-3

## **⚠ WARNING**

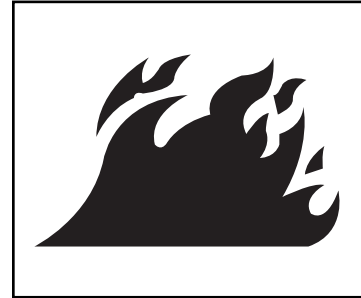
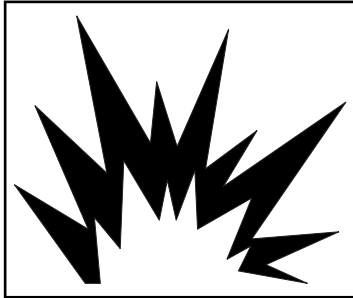

**HIGH PRESSURE CAN CAUSE SERIOUS INJURY IF EQUIPMENT IS INSTALLED OR USED INCORRECTLY—  
READ, UNDERSTAND, AND OBSERVE ALL WARNINGS AND INSTRUCTIONS IN THIS MANUAL.  
OPERATE EQUIPMENT ONLY AFTER ALL INSTRUCTIONS ARE CLEARLY UNDERSTOOD.**

### **INJECTION HAZARD**

Spray from the gun, hose leaks, or ruptured components can inject fluid into your body and cause extremely serious injury, including poisoning or the need for amputation. Splashing fluid in eyes or on skin can also cause a serious injury.

- Fluid injected into the skin might look like just a cut, but is a serious injury and should be treated as such. **GET IMMEDIATE MEDICAL ATTENTION. INFORM THE PHYSICIAN WHAT TYPE OF MATERIAL WAS INJECTED.**
- Do not point the spray gun at anyone or any part of the body.
- Do not put fingers or hand over the spray tip.
- Do not stop or detect fluid leaks with a rag, hand, body or glove.
- Do not use a rag to blow back fluid. **THIS IS NOT AN AIR SPRAY GUN.**
- Be sure the trigger operates safely before spraying.
- Engage the gun safety when not spraying.
- **ALWAYS RELIEVE THE PRESSURE WHENEVER WORKING ON THE SPRAY GUN.**
- Tighten all fluid connections before operating equipment.
- Check all hoses, tubes, and couplings daily. Replace all worn, damaged, or loose parts immediately.

Hazardous fluids or toxic fumes can cause serious injury or death if splashed on skin or in the eyes, swallowed or inhaled.

### **TOXIC FLUID HAZARD**

- Know the specific hazards of the fluid you are using. This information is on the MSDS for the material being used. Read all fluid manufacturer's warnings.
- Store hazardous fluids in approved containers only. Dispose of all hazardous fluids in accordance with all state, local and national guidelines.
- Wear the appropriate protective clothing, gloves, eye-wear and respirator.

Equipment misuse can cause the equipment to fail, malfunction, or start unexpectedly and result in serious injury.

### **EQUIPMENT MISUSE HAZARD**

- This equipment is for professional use only.
- Read and understand all instructional manuals, tags, and labels before operating equipment.
- Use the equipment only for its intended purpose. If you are unsure about its purpose call your local Binks distributor.
- Do not alter or modify this equipment. Use only genuine Binks parts.
- Do not exceed the maximum working pressure of the lowest rated system component. **THE MAXIMUM RATING OF THE AA4000 IS 4000 PSI (275 BAR) FLUID PRESSURE. DO NOT EXCEED THE FLUID PRESSURE RATING.**
- Route all hoses away from all sharp edges, moving parts, hot surfaces and high traffic areas.
- Do not use hoses to pull the equipment.
- Use only Binks approved hoses. Do not remove spring guards from hoses, these are on the hoses to prevent rupture from kinking at the connectors.
- Use only solvents compatible with hoses and wetted parts of the equipment used.
- Comply with all applicable local state and national fire, electrical, and other safety regulations.

Improper grounding, poor air ventilation, open flames, or sparks can cause a hazardous condition and result in fire or explosion and cause serious injury.

### **FIRE AND EXPLOSION HAZARD**

- Ground the equipment and object being sprayed.
- Provide fresh air ventilation to avoid the build up of flammable fumes from the material being sprayed or from solvent.
- Extinguish all open flames or pilot lights in spray area.
- Electrically disconnect all equipment in the spray area.
- Keep the spray area free from all debris, including solvent rags.
- If there is any static sparking while using the equipment, **STOP SPRAYING IMMEDIATELY.** Identify and correct problem.

## SPRAY GUN SET-UP

1. Connect your high-pressure airless fluid hose to the gun fluid inlet and tighten securely.
2. Connect your air hose to the gun air connection and tighten securely.
3. Set the fluid pressure at the gun's lower end of the pressure range. A typical starting fluid pressure is 1600 psi. Actual starting pressure points may be higher or lower than 1600 psi and depend on the setup—including the type of pump used, the type of material sprayed, and the spray gun itself.
4. Using the control knob on the gun air regulator, set the air pressure at zero.
5. To test the spraying pattern, spray a piece of wood or cardboard with a fast pass about one foot away from the piece. The results of the test will allow you to determine the uniformity of the particle size and spraying pattern.
6. If the spraying pattern develops tails or is not uniform, gradually increase the air pressure as necessary to develop a uniform spraying pattern. Typically, 10 psi air pressure is adequate. The air is used to assist the atomization of the coating.
7. If the quality of spray is acceptable, begin spraying. If the spraying rate is too slow to keep up with the production line speed, or if the quantity of material sprayed is inadequate for acceptable coverage, gradually increase the fluid pressure in 50 psi increments using the fluid regulator control knob. However, note that as the fluid pressure increases, more air is needed to eliminate the tails.

Consistency in spraying can be increased across spray gun operators and similar spraying jobs by developing pressure standardization charts. Repeat step 6 until the required material coverage and spraying speed are achieved. If the maximum fluid pressure is reached before the required material coverage and spraying speed are achieved, you may need to switch to a larger fluid tip.

### TYPICAL HOOK-UP

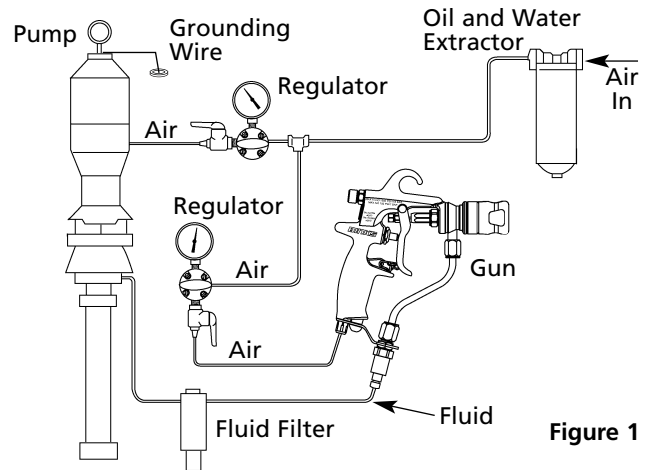

Figure 1

Fan pattern adjustment: turn knob counterclockwise to increase pattern; clockwise to decrease pattern (Fig. 2).

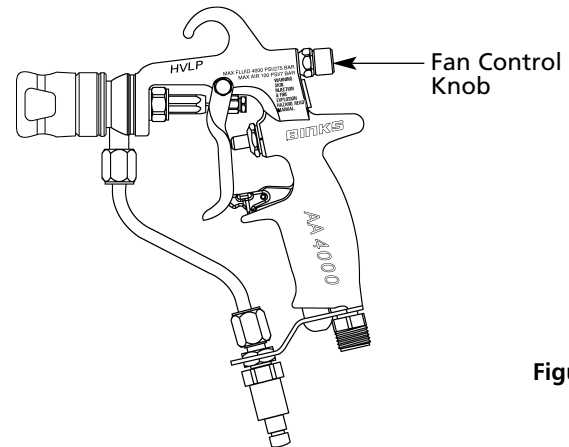

Figure 2

### NOTE

Fan adjustment feature requires approximately 25 psi or higher of air inlet pressure. This is recommended for fluid pressures lower than 500 psi. Higher fluid pressure requires higher air inlet pressures to accommodate pattern adjustment.

## FLUID TIP SELECTION

Factors to consider in selecting a fluid tip for an air-assisted airless spray gun include (1) the size of the parts being sprayed; (2) the production line speed; (3) the material flow rate and film thickness; (4) the viscosity of the material applied; (5) the type of material applied; and

(6) the quality of atomization of the coating required. The selection of a fluid tip necessary to perform a specific spraying job is best determined through a combination of experimentation and expert advice from your material and equipment suppliers.

## FLUID HOSES

Air-assisted airless spray guns operate at fluid pressures higher than operating pressures of air spray guns. As a result, when operating an air-assisted airless spray gun, it

is critical to select the appropriate fluid hose that is rated for the pressure range at which the airless gun is operated.

## TROUBLESHOOTING DEFECTIVE SPRAY PATTERNS

The following procedure summarizes the steps that an operator must immediately take when the first signs of a defective spray pattern emerge.

1. Check the external portion of the fluid tip for material buildup. If buildup has occurred, secure the gun trigger safety switch and clean the gun fluid tip with a non-metal soft brush.
2. If the spray pattern exhibits signs of tails at the top or bottom ends of the pattern, increase the air pressure gradually until the tails disappear.
3. If increasing air pressure does not dissipate the tails, the fluid tip may be worn and may need to be replaced. Another sign of the need to replace a worn tip is a gradual decline in spraying pattern width.

4. If cleaning or replacing the fluid tip does not dissipate the tails; the spraying defect is most likely due to the material temperature and/or viscosity.
5. If pattern pulsation or blinking occurs, check the pressure regulators, all downstream regulators, and the pump. These may require further adjustment or even repairs.

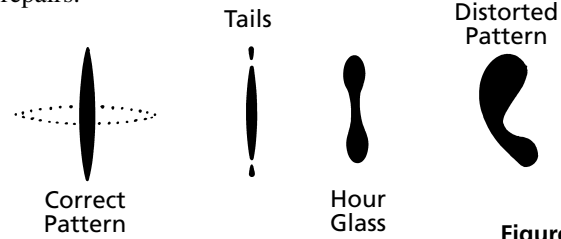

**Figure 3**

## GENERAL TROUBLESHOOTING



PROBLEM	CAUSE	ACTION
Fluid leaking from the back of seal cartridge assembly (8)	Worn seal or needle shaft.	Replace needle packing cartridge (7).
Fluid leaking from the front of the gun	Needle ball worn or damaged. Worn seat assembly.	Replace needle packing cartridge (7). Replace fluid seat (3).
Fluid in air passages	Spray tip seal leaking. Leaking around fluid seat.	Tighten air cap/nozzle guard assembly (1) Replace carbide tip assembly (2). Tighten or replace fluid seat (3).
Slow fluid shut off	Fluid buildup on cartridge assembly.	Clean or replace cartridge assembly (7).
No fluid output when triggered	Tip orifice plugged.  Collet on needle has slipped.  Fluid filter or fluid hose plugged.	<b>Turn off fluid supply. Relieve pressure into a closed-grounded container. Engage trigger safety.</b> Remove air cap/nozzle guard assembly (1) and the carbide tip (2). Clean or replace carbide tip assembly (2). <b>Turn off fluid supply. Relieve pressure into a closed-grounded container.</b> Remove trigger (19). Remove needle packing cartridge (7). Loosen collet and move until the needle is flush with the rear of the collet. Tighten collet. <b>Turn off fluid supply. Relieve pressure into a closed-grounded container. Turn off air supply to pump and relieve fluid pressure with bypass valve. Engage trigger safety. Very slowly loosen the hose connection at the gun to relieve any pressure in hose. Remove hose and clear obstruction.</b>

## IMPORTANT REGULATORY NOTE

The AA-4000 Air-Assisted H.V.L.P. hand spray gun combines the proven efficiency of the Binks compliant spray guns with air-assisted atomization to yield a reliable, carefully engineered compliant spray gun. With 25' of 5/16" I.D. air hose and regulator set at only 20 p.s.i. the compliant air cap registers 10 p.s.i. of atomization air to shape and soften the spray pattern. The AA-4000 air-assisted H.V.L.P. gun operates at high transfer efficiencies and fully complies with all government regulations for H.V.L.P. spray guns.

	Max. Fluid Input:	4000 p.s.i.
Max. static air pressure at regulator with 25' of hose to inlet:	20 p.s.i.	
Max. Dynamic Gun Inlet Air Pressure:	15 p.s.i.	
	Gun Body:	Forged Aluminum Alloy
	Fluid Path:	Stainless Steel and Tungsten Carbide

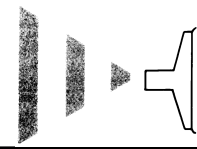
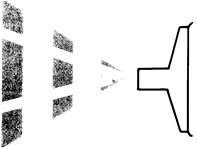
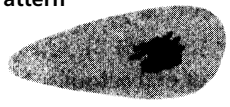
## SPRAY PATTERN TROUBLESHOOTING

PROBLEM	CAUSE	ACTION
<b>Fluttering Spray Pattern</b> 	Insufficient fluid supply.  Air in paint supply line.  Attempting to "feather" (Partially trigger gun).	Adjust fluid regulator or fill fluid supply tanks.  Check and tighten pump siphon hose connections, bleed air from paint line.  Cannot feather with an AA4000 gun.
<b>Striping Spray – Fingers</b> 	Carbide tip partially plugged.	Clean or replace carbide tip assembly.
<b>Irregular Pattern</b> 	Fluid builds up on carbide tip, or tip partially plugged.  On defective side of pattern, air horn holes are plugged.	Clean carbide tip.  Clean air horn holes with solvent and a soft brush.
<b>Pattern pushed to one side, same side of air cap gets dirty</b> 	On defective side of pattern, air horn holes are plugged.	Clean air horn holes with solvent and a soft brush or toothpick.

## AIR-ASSISTED AIRLESS SPRAY GUN MAINTENANCE AND CLEANING

Maintenance of air-assisted airless spray guns includes (1) fluid tip wear and replacement; (2) lubrication; and (3) cleaning of the gun.

### FLUID TIP

Operating an air-assisted airless spray gun with a worn fluid tip will result in increased usage of spraying material and therefore, HAP emissions. For example, an increase in the diameter of a tip from 0.015 inch to 0.021 inch due to wear can result in up to a 100 percent increase in material consumption and cost. To prevent waste in spraying material and non-value-adding costs, a maintenance schedule that includes fluid tip inspection and replacement must be established.

### LUBRICATION

Proper lubrication is essential for optimum spray gun performance. Lubrication allows the equipment to operate easily and correctly. The spray gun should be lubricated after each cleaning. The points that need lubrication during the maintenance of air-assisted airless spray guns include (1) the fluid needle packing; (2) trigger pivot point. Gun lube is used to lubricate the fluid needle packing and trigger pivot point.

### ⚠ CAUTION

Never immerse the entire gun in solvent or thinners. Some gun parts will lose their lubricative film and wear more quickly. Additionally, solvents may carry impurities throughout the gun body and allow them to clog small air and fluid passages.

### CLEANING

The following steps summarize the procedure for cleaning air-assisted airless spray guns:

1. Turn off the atomizing air supply to the gun.
2. Turn off air supply to the pump and relieve fluid pressure. This may be accomplished by opening the bypass/priming valve, if so equipped.
3. Place the siphon (suction) tube into a solvent container. If pump is directly immersed in material, remove the pump and immerse it in a solvent container.

### NOTE

Use only compatible solvents that are identified as approved for cleaning and wash-off use.

4. Place the gun trigger safety switch in the locked position.
5. Remove the fluid tip and place it in a closed solvent container.
6. Adjust the pump air supply regulator to its lowest level (counter-clockwise).
7. Place the gun trigger safety switch in the unlocked position.
8. Turn on the air supply to the pump and close the bypass/priming valve, if so equipped.
9. Slowly adjust the pump air supply regulator until the pump begins to cycle.
10. Trigger the gun into a closed container until the fluid runs clear. *(continued)*

### ⚠ WARNING

Failure to reduce pump air supply pressure or to use a closed container can result in material "bounce-back". Material "bounce back" can cause injury and damage.

### NOTE

During cleaning, the gun may only be sprayed into a closed container, never flush the gun into the air or spray booth.

## CLEANING (Continued)

11. Using a rag dampened with solvent, wipe the exterior surface of the gun. Additionally, some solvents are prohibited from being used for cleaning. The operator must take care to use only approved cleaning solvents for equipment cleaning. These materials are clearly labeled as approved for cleaning and wash off operations. If the operator has any question on selecting appropriate cleaning solvents, the operator should consult a supervisor or plant environmental staff.

## WIRE AND BALL ASSEMBLY AND SEAT REPLACEMENT

Refer to assembly drawing on page 7 to locate numbered items.

1. Engage the trigger safety.
2. Shut off fluid pump and disconnect its air or power supply.
3. Release pressure from the entire fluid system, from the pump to the spray gun.
4. Remove AA10HP air cap/nozzle assembly (1) and spray tip (2). Remove trigger (19) by removing the trigger stud (12) and the trigger screw (11).
5. Remove the AA4000 needle packing cartridge (7).
6. Carefully install new AA4000 needle packing cartridge (7).
7. Remove fluid seat (3) and o-ring.
8. Install new fluid seat (3) and o-ring.
9. Reinstall trigger (19), trigger stud (12) and trigger screw (11).
10. Reinstall spray tip (2) and AA10HP air cap/nozzle assembly (1).

## AIR VALVE REPLACEMENT

1. Engage the trigger safety.
2. Shut off fluid pump and disconnect its air or power supply.
3. Release pressure from the entire fluid system, from the pump to the spray gun.
4. Remove trigger (19) by removing the trigger stud (12) and the trigger screw (11).
5. Remove air valve assembly (20).
6. Replace air valve assembly (20).
7. Reinstall trigger (19), trigger stud (12) and trigger screw (11).

## PARTS LIST

When ordering, please specify Part No.  
(Not all part numbers are available for purchasing.)

ITEM NO.	PART NO.	DESCRIPTION	QTY.	ITEM NO.	PART NO.	DESCRIPTION	QTY.
1	54-5345▼	AA10HP AIR CAP/NOZZLE .....	1	15	54-4943	FLUID TUBE BRACKET .....	1
1A	20-6784♦	FLUOROELASTOMER SEAL (2-015)	1	16	54-4975▲	PUSH IN TUBE FITTING .....	1
2	113-0XXXX	CARBIDE TIP ASSEMBLY .....	1			1/8" NPT(M) X 3/8" O.D.	
		(See Tip Selection Chart, pg. 8)		17	20-6718	BUTTON HEAD CAP SCREW .....	1
3	54-4960*▼	FLUID SEAT (Tungsten Carbide .....	1	18	54-4944●	FLUID INLET FITTING .....	1
		Standard or UHMW Optional 54-4926)		19	54-4937	TRIGGER.....	1
3A	20-6037■	O-RING (Part of 54-4960) .....	1	20	54-4909*	AIR VALVE ASSEMBLY .....	1
4	54-4906	FLUID TUBE ASSEMBLY.....	1	21	71-28	D.M. NIPPLE.....	1
5	54-4986	GUN HEAD .....	1			1/8" NPT(m) x 1/4" NPS(m)	
6	54-4923*	FRONT HEAD GASKET .....	1	22	54-4725	FILTER ASSEMBLY (100 Mesh).....	1
7	54-4963*	NEEDLE PACKING CARTRIDGE.....	1	23	54-4910	TRIGGER LOCK .....	1
		(4,000 PSI maximum)		24	54-4911	LOCK PIN .....	1
8	—	GUN BODY (Not Sold Separately) .....	1	25	54-4912	SAFETY LOCK WAVE SPRING .....	1
9	54-4925	FLUID INLET NUT.....	1				
10	54-5328	SIDE PORT CONTROL ASS'Y(AA10) ..	1				
10A	20-6785‡	FLUOROELASTOMER SEAL (2-004)	1				
11	54-4939	TRIGGER SCREW .....	1				
12	54-4938	TRIGGER STUD .....	1				
13	—	FLAT PLUG (Not Sold Separately) .....	1				
14	54-4947	FLUID TUBE BRACKET SPACER ....	1				

▼ Also available as part of AA10HP Conversion Kit 54-5301 (for converting AA4000 spray guns w/AA4 air caps to AA4000 spray guns with AA10HP air caps).

♦ Also available: Minimum order quantity of 2 for all o-rings.

\* Available as part of Repair Kit 54-4993.

■ Also available: 20-6037-K10 (Kit of 10 o-rings).

‡ Also available: Minimum order quantity of 2 for all o-rings.

▲ Alternate push-in tube fitting (16) is included in gun package.

● Alternate fluid inlet fitting (18)—order separately.

## AA4000 AIR-ASSISTED AIRLESS SPRAY GUN

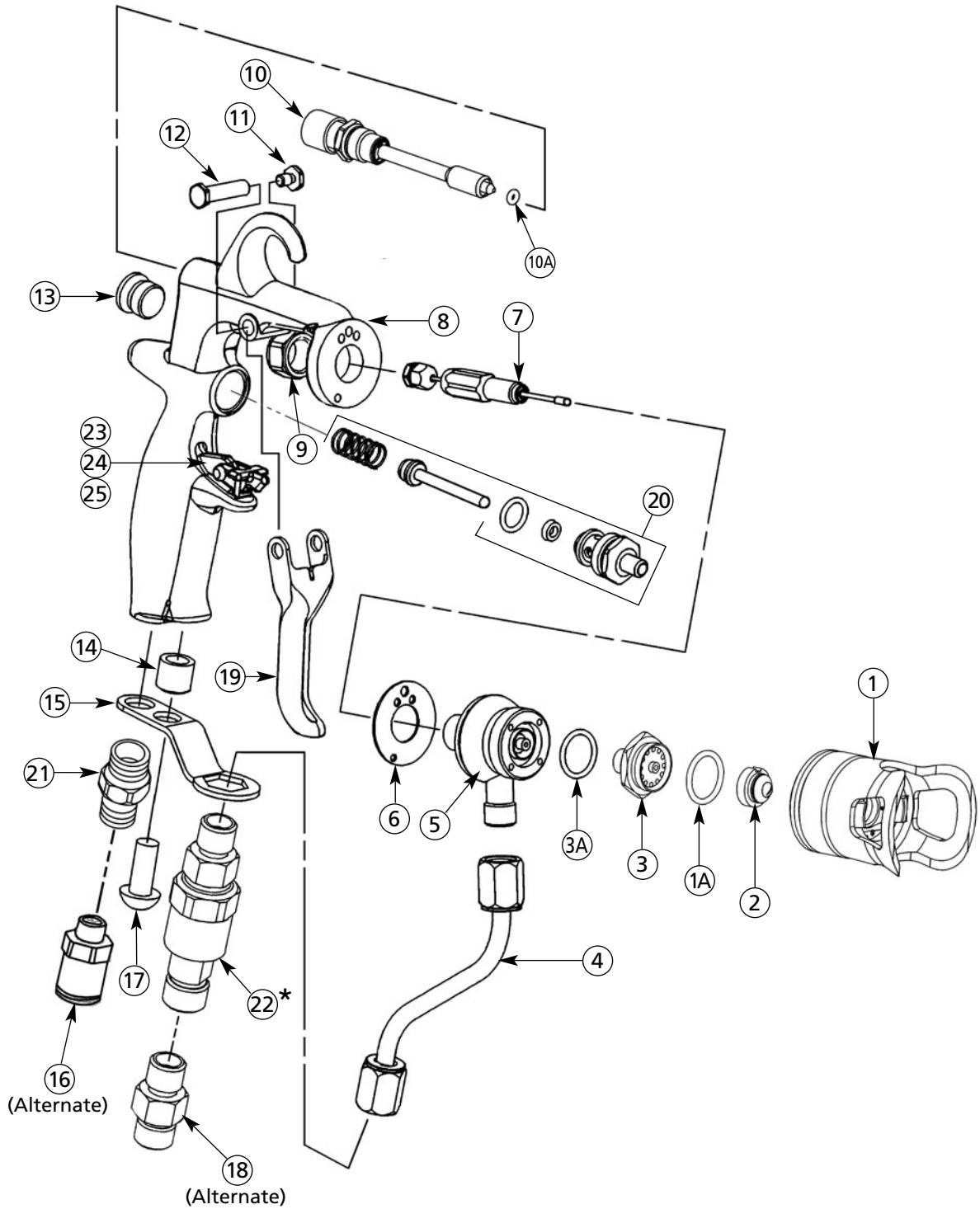

\*Do not overtighten for ease of filter replacement.  
Adequate torque required is 5–6 ft. lbs.

## SPRAY TIP ASSEMBLY SELECTION CHARTS

<b>HOW TO ORDER THE AA 4000 AIR-ASSISTED AIRLESS SPRAY GUN WITH AA10HP 4000-0000-10HP (AA10HP Air Cap less Spray Tip)</b> Spray Tip must be ordered separately. Use this chart to determine orifice size and fan size required*. *Note: Listed Fan Widths based on 1000 PSI with water. Actual results may vary, depending on material viscosity.						PART NUMBER	DESCRIPTION	ORIFICE	FAN WIDTH (IN.)	GPM CAPACITY @500 PSI WATER
	114-01104	TIP ASSEMBLY	.011	4	.060					
	114-01106	TIP ASSEMBLY	.011	6	.060					
	114-01108	TIP ASSEMBLY	.011	8	.060					
	114-01110	TIP ASSEMBLY	.011	10	.060					
	114-01112	TIP ASSEMBLY	.011	12	.060					
	114-01114	TIP ASSEMBLY	.011	14	.060					
	114-01304	TIP ASSEMBLY	.013	4	.090					
	114-01306	TIP ASSEMBLY	.013	6	.090					
	114-01308	TIP ASSEMBLY	.013	8	.090					
	114-01310	TIP ASSEMBLY	.013	10	.090					
	114-01312	TIP ASSEMBLY	.013	12	.090					
	114-01314	TIP ASSEMBLY	.013	14	.090					
	114-01316	TIP ASSEMBLY	.013	16	.090					
	114-01506	TIP ASSEMBLY	.015	6	.120					
	114-01508	TIP ASSEMBLY	.015	8	.120					
	114-01510	TIP ASSEMBLY	.015	10	.120					
	114-01512	TIP ASSEMBLY	.015	12	.120					
	114-01514	TIP ASSEMBLY	.015	14	.120					
	114-01516	TIP ASSEMBLY	.015	16	.120					
	114-01518	TIP ASSEMBLY	.015	18	.120					
	114-01706	TIP ASSEMBLY	.017	6	.160					
	114-01708	TIP ASSEMBLY	.017	8	.160					
	114-01710	TIP ASSEMBLY	.017	10	.160					
	114-01712	TIP ASSEMBLY	.017	12	.160					
	114-01714	TIP ASSEMBLY	.017	14	.160					
	114-01716	TIP ASSEMBLY	.017	16	.160					
	114-01718	TIP ASSEMBLY	.017	18	.160					
	114-01906	TIP ASSEMBLY	.019	6	.190					
	114-01908	TIP ASSEMBLY	.019	8	.190					
	114-01910	TIP ASSEMBLY	.019	10	.190					
	114-01912	TIP ASSEMBLY	.019	12	.190					
	114-01914	TIP ASSEMBLY	.019	14	.190					
	114-01916	TIP ASSEMBLY	.019	16	.190					
	114-01918	TIP ASSEMBLY	.019	18	.190					
	114-02110	TIP ASSEMBLY	.021	10	.240					
	114-02112	TIP ASSEMBLY	.021	12	.240					
	114-02114	TIP ASSEMBLY	.021	14	.240					
	114-02116	TIP ASSEMBLY	.021	16	.240					
	114-02118	TIP ASSEMBLY	.021	18	.240					
	114-02410	TIP ASSEMBLY	.024	10	.310					
	114-02412	TIP ASSEMBLY	.024	12	.310					
	114-02414	TIP ASSEMBLY	.024	14	.310					
	114-02416	TIP ASSEMBLY	.024	16	.310					
	114-02418	TIP ASSEMBLY	.024	18	.310					
	114-02710	TIP ASSEMBLY	.027	10	.385					
	114-02712	TIP ASSEMBLY	.027	12	.385					
	114-02714	TIP ASSEMBLY	.027	14	.385					
	114-02716	TIP ASSEMBLY	.027	16	.385					
	114-02718	TIP ASSEMBLY	.027	18	.385					

### FLUID SEAT APPLICATION CHART

APPLICATION CHART	
Carbide (Standard)	54-4960
UHMW (Optional)	54-4926

### AA10HP CONVERSION KIT

**54-5301** Kit for converting AA4000 guns with AA4 air cap to AA4000 gun with AA10HP air cap.

### ACCESSORIES

HOSES	
71-4990	15' Polyurethane Air Tubing ASM w/fittings, 3/8" O.D., 1/4" I.D.
71-4991	25' Polyurethane Air Tubing ASM w/fittings, 3/8" O.D., 1/4" I.D.
71-8087	15' 3/16" High Pressure Fluid Hose Assembly
71-8088	25' 3/16" High Pressure Fluid Hose Assembly
FITTINGS	
54-4975	1/8" NPT Male x 3/8" O.D. Push-In Tube Fitting (optional)
54-4976	1/4" NPT Female x 3/8" O.D. Push-In Tube Fitting (optional)
FLUID FILTER	
103-1241	100 Mesh Inline Filter, 4000 PSI working pressure
54-3655	100 Mesh (Element) Gun Mounted Filter, 5800 PSI w.p.
54-5010	100 Mesh (Screen) Gun Mounted Filter, 4000 PSI w.p.
54-4725	100 Mesh (Element) Gun Mounted Filter, 4000 PSI w.p.

FLUID REGULATOR	
845011	Less Gauge, 1000 to 3000 PSI regulated range
845013	Less Gauge, 2000 to 5000 PSI regulated range
CLEANING KIT	
54-4994	Cleaning Kit: Includes one standard stiff nylon pipe cleaning brush, full-size nylon brush, tip cleaner and Binks <i>Gunners Mate</i> lubricant.
TEST GAUGES	
54-5327	H.V.L.P. Test Gauge AA10

Refer to page 6 for Repair Kits.

## Binks Worldwide Sales and Service Listing: [www.binks.com](http://www.binks.com)

### ITW Industrial Finishing

Binks has authorized distributors throughout the world. For technical assistance or the distributor nearest you, see listing below.

#### U.S./Canada Technical Service Office:

195 Internationale Blvd., Glendale Heights, IL 60139  
 Toll-Free Telephone: 1-888-992-4657 (U.S.A. and Canada only)  
 Toll-Free Fax: 1-888-246-5732

### WARRANTY

This product is covered by Binks' 1 Year Limited Warranty.

**77-2839R-3** Revisions: (P8) Replaced Spray Tip Assembly Selection Charts.



An Illinois Tool Works Company