









SATAjet® K3 HVLP

Nozzle size*	0.8	1.0	1.2
 Standard version	93385	92924	93393
 DIGITAL version Pressure reading from 3-99 psi	93286	92718	93294
 DIGITAL version with stainless steel fluid passages		94060	94078
 Nozzle sets only	92783	92791	92809

Air consumption
At 36 psi / 2.5 bar inlet pressure: approx 20 cfm / 560 NL/min

*Larger nozzle sets available

SATAjet® K3 RP

Nozzle size*	0.8	1.1	1.3	1.5
 Standard version	92932	93336	93344	93351
 DIGITAL version Pressure reading from 3-99 psi	92692	93120	93138	93146
 DIGITAL version with stainless steel fluid passages		94029	94037	
 Nozzle sets only	92494	92502	92510	92528

Air consumption: At 36 psi / 2.5 bar inlet pressure: approx 15.5 cfm / 450 NL/min, Air operating pressure: 35-44 psi / 2.5-3.0 bar

*Larger nozzle sets available

Product Numbers

Recommended accessories

Accessories

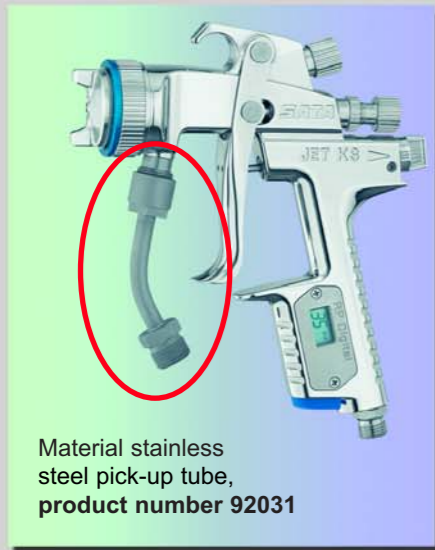

Material stainless steel pick-up tube, product number 92031

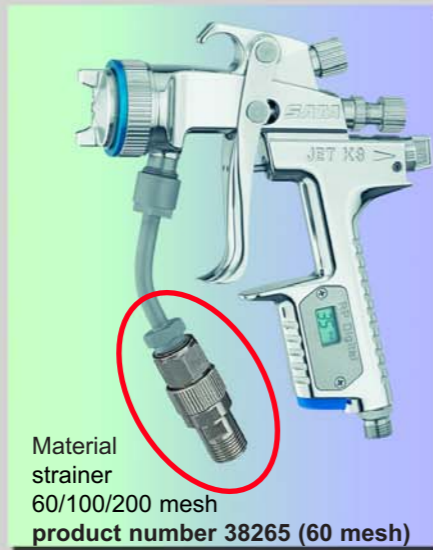

Material strainer 60/100/200 mesh product number 38265 (60 mesh)

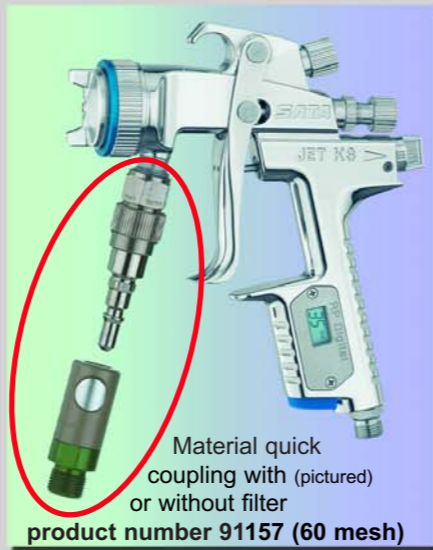

Material quick coupling with (pictured) or without filter product number 91157 (60 mesh)

In addition, SATA offers other material delivery systems, such as Vario-Top-Spray™ double dia-phragm pump in various product versions as well as pressure tanks in sizes from 2 liter to 48 liter (2 qt. to 65 gal.) capacity and air/material hoses.



Distributed nationwide by:

Dan-Am Co.®

One Sata Drive, P.O. Box 46, Spring Valley, MN 55975
 • Order Desk 800-533-8016
 • Fax 800-633-7282
 • Business 507-346-7776

www.satausa.com • e-mail: prod@satausa.com

Your SATA distributor

K3 HVLP-RP 03E 5/1/02 Printed in the USA



SATAjet K3 HVLP and SATAjet K3 RP

For achieving great work

High performance **SATAjet® K3** spray guns – the super class for material pressure fed paint systems

Also available with DIGITAL™ readout integrated in the spray gun handle for pressure setting and pressure control



DIN EN ISO 9001



"Always look for the original and distinctive SATA® design"

High performance spray guns for refined painting

SATAjet® K3 - the "Super Saver"



The SATAjet K3 HVLP ensures a paint job in a class of its own and provides perfect finish results with all paint systems. The result of innovative nozzle design is a homogeneous fan pattern with a maximum transfer rate. No other air atomizing technique offers higher transfer efficiency than HVLP. The SATAjet K3 HVLP clearly exceeds the minimum mandated 65 % transfer rate and provides unparalleled economy. Not only does it meet approved worldwide HVLP standards with a maximum 0.7 bar / 10 psi air cap pressure (at an inlet pressure of 2.5 bar / 35 psi) but it

also meets the requirement for the highest possible transfer rate. The SATA quick change feature means a quick air cap change with only 1.5 turns.

The SATAjet K3 HVLP DIGITAL model is also available with digital pressure setting and pressure control readout integrated in the spray gun handle.

Air consumption approx. 20 cfm/560 NL/min, 36 psi./2.5 bar

HVLP and RP™ two systems - one goal

The future is HVLP low pressure and RP high-pressure technology whenever air-atomizing spray guns are required. According to VOC legislation, only coating systems with high transfer rates may be used. HVLP and RP technology corresponds fully with these requirements. Material savings create significant economic advantages

§ - VOC legislation

The SATAjet K3 HVLP and SATAjet K3 RP provide material transfer rates significantly higher than 65 % and therefore meet legal requirements.

Depending on personal preference, the paint material to be used and the object to be painted, every painter may choose either the "Super Speed" SATAjet K3 RP or the "Super Saver" SATAjet K3 HVLP.

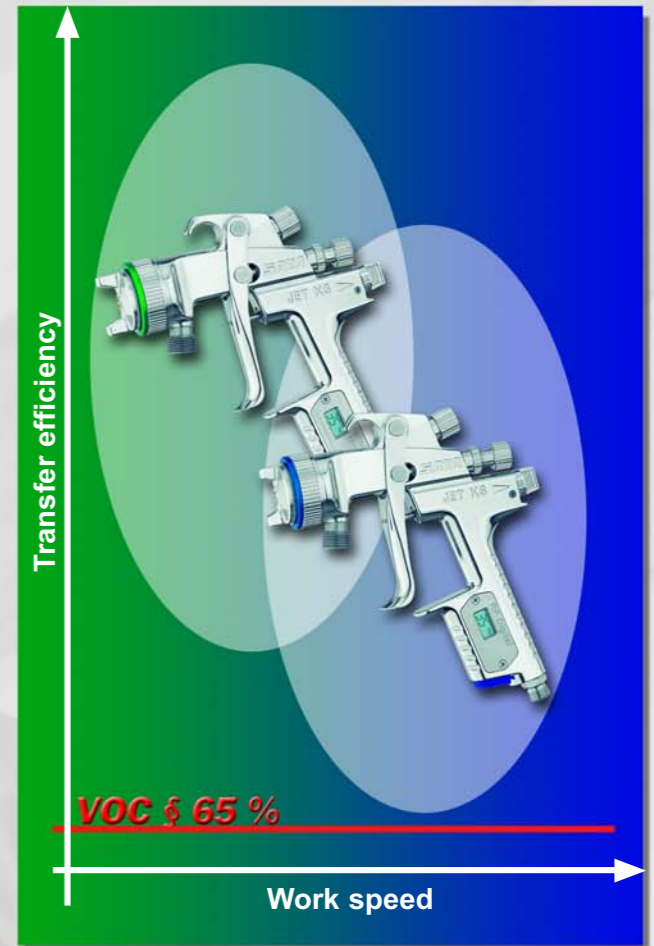

SATAjet® K3 - the "Super Speed"

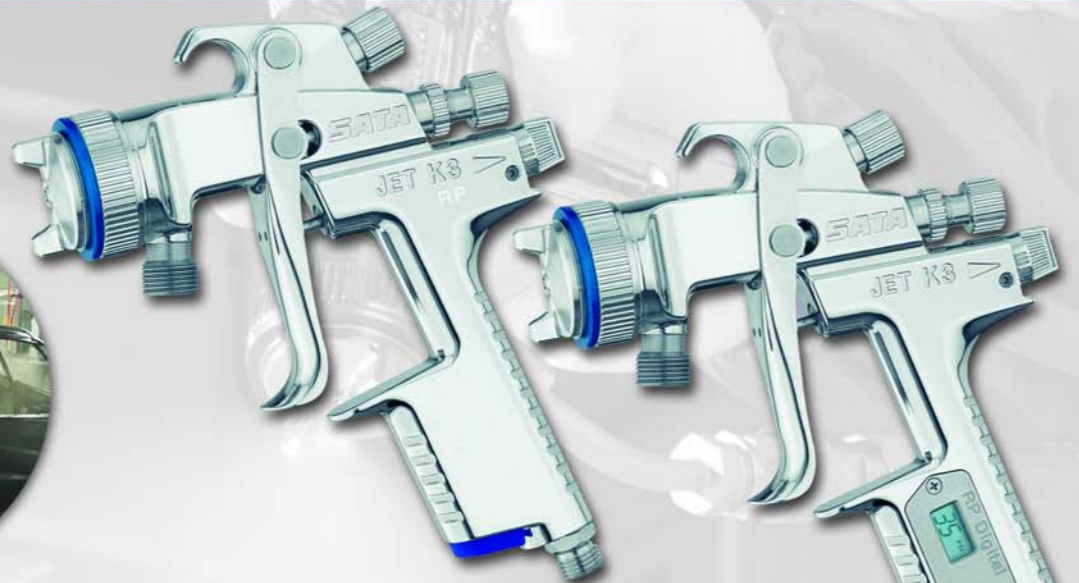

A powerful spray gun, the SATAjet K3 RP features optimized conventional high-pressure technology with remarkably high transfer efficiency. By lowering the inlet pressure, this conventional high-pressure spray gun generation combines the advantage of fast working speed with the high material transfer efficiency required by VOC legislation. The SATAjet K3 RP is no different in handling characteristics when compared to conventional spray guns.

Due to awesome ergonomics, the SATAjet K3 perfectly fits every painter's hand.

The SATAjet K3 RP DIGITAL is also available with integrated inlet pressure control adjustment and digital pressure readout in the handle.

Air consumption approx. 15.5 cfm/430 NL/min, 36 psi./2.5 bar



Advantages of the DIGITAL™ product version

Inlet pressure can now be adjusted and digitally displayed with the integrated air micrometer in the spray gun handle.

The SATAjet K3 DIGITAL spray guns are equipped with worldwide unique new technology. The inlet pressure to the spray gun can be adjusted with the integrated air micrometer in the spray gun handle. The integrated digital pressure readout displays the operating pressure exactly.

This feature fulfills an important principle for the highest color matching accuracy and precision for achieving the ultimate finish result.

The SATAjet K3 DIGITAL has been submitted for patent worldwide.

- Exact spray pressure control with digital readout
- Highest color matching accuracy – perfect finishes
- Highest transfer efficiency – unbeaten cost savings