

PERFORMANCE
JUST GOT A NEW NUMBER.



2100 SPRAY GUN

- VERSATILE
- RUGGED
- COMFORTABLE
- CORROSION RESISTANT

2100

2100 . . . THE NEXT GENERATION

THE 2100 IS A CONVENTIONAL, FULL-SIZE SPRAY GUN WHICH CAN BE USED TO SPRAY A WIDE RANGE OF MATERIALS INCLUDING ADHESIVES, EPOXY, AND ABRASIVE FLUIDS.



- Corrosion resistant stainless steel fluid passages designed for waterborne materials
- Curved, ergonomic handle reduces fatigue
- Integrated head has fewer parts for quick repair
- Stainless steel threads won't cross-thread, increasing life
- Lowered trigger pivot point reduces fatigue
- Cheater valve adjusts air at the gun, saving operator time
- New "**Maximum Delivery**" air nozzles have better atomization for greater product finish with less material

The 2100 spray gun is a durable, full-sized gun that is comfortable, well balanced, and easy to use. A specially designed grip measurably improves operator control, balance, and spray quality. Supported by the largest selection of air nozzles in the industry, the model 2100 will spray all conventional coatings, including those with high solids. The 2100 spray gun features a forged aluminum body that has been precision machined, and brass air nozzles and knobs that are nickel plated. These features ensure that the 2100 gun will withstand many years of use under the toughest working conditions.

ATION IN SPRAY GUN TECHNOLOGY.

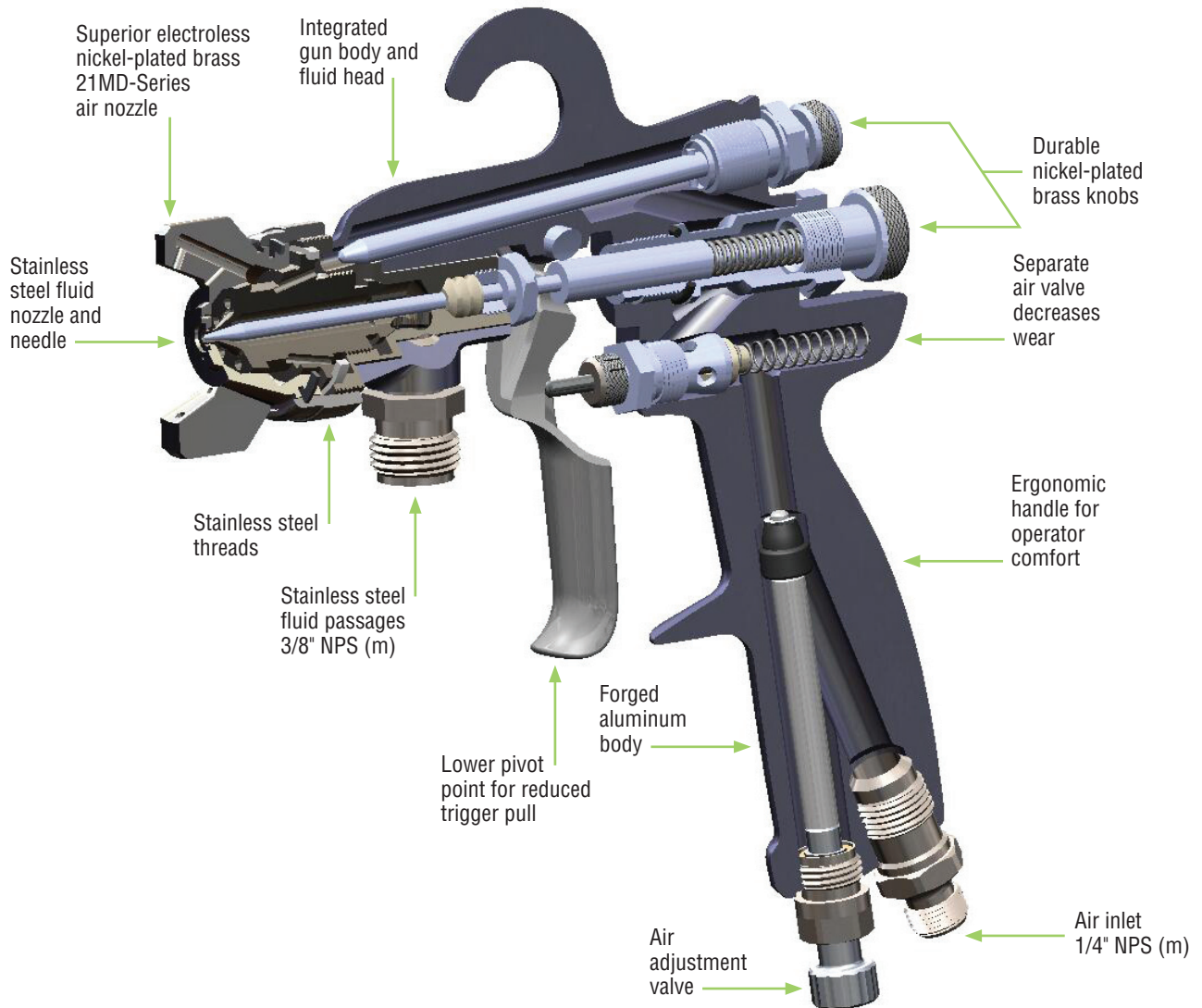

Maximum Delivery Air Nozzles								
Type of Fluid to be Sprayed	Air Nozzle	Type	CFM at			Max. Pattern @ 8"	Fluid Nozzle	Fluid Needle Numbers
			30 PSI	50 PSI	70 PSI			
VERY THIN TO MEDIUM 14-30 Sec. Zhan 2	46-21MD-1	SE	12	17.3	23	11"	66SS	565
VERY THIN TO MEDIUM 14-40 Sec. Zhan 2	46-21MD-2	SE	15.2	22.2	29.6	11"	66SS	565
	46-21MD-2	SE	12.5	18.3	24.4	13"	67SS	567
VERY THIN TO MEDIUM 14-30 Sec. Zhan 2	46-21MD-3	PE	11.6	16.6	22.2	16"	63BSS	563A

NOTE: 21MD-1 AND 21MD-2 air nozzles can be used with pressure set-ups producing spray patterns approximately 12" wide.
PE – Pressure External, SE – Siphon External

2100 SPECIFICATIONS

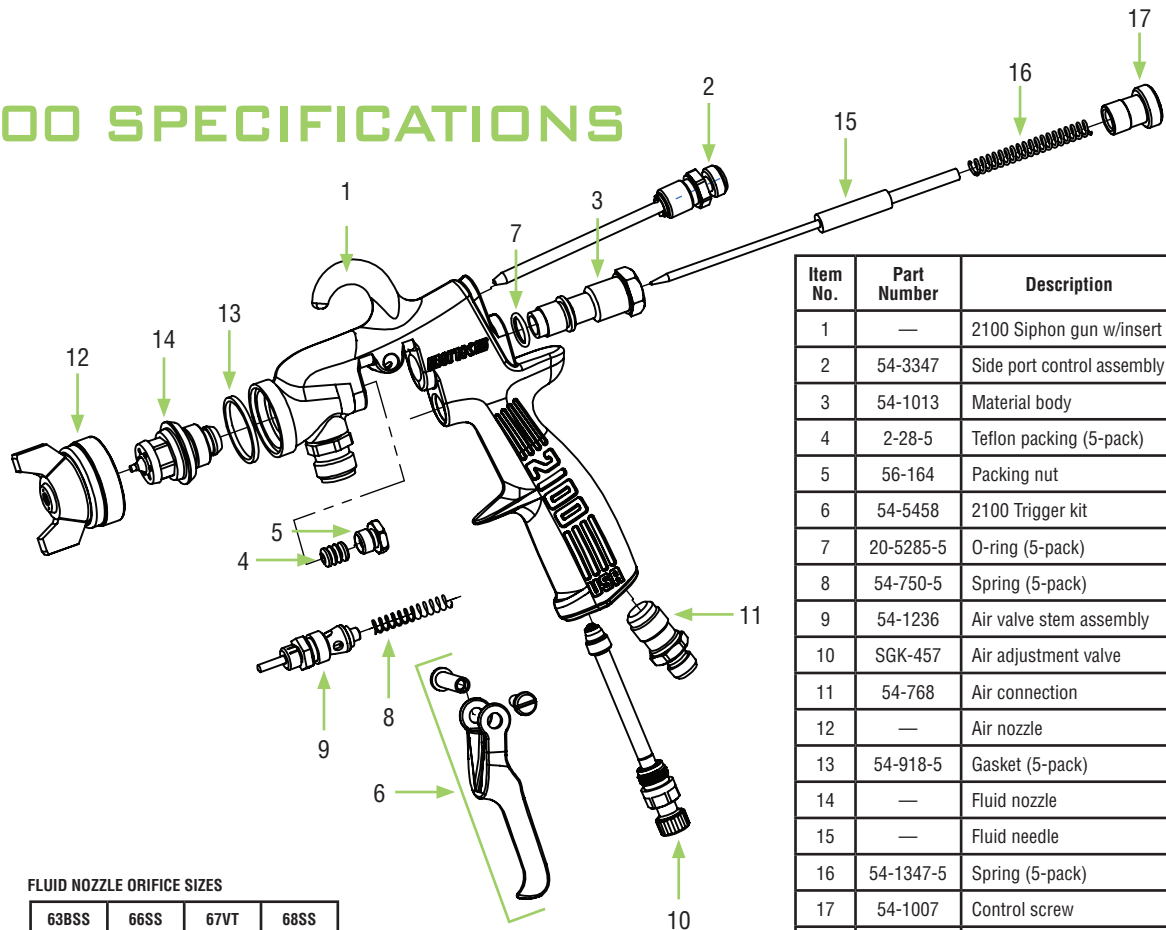

FLUID NOZZLE ORIFICE SIZES

63BSS	66SS	67VT	68SS
.046	.070	.086	.110

Item No.	Part Number	Description
1	—	2100 Siphon gun w/insert
2	54-3347	Side port control assembly
3	54-1013	Material body
4	2-28-5	Teflon packing (5-pack)
5	56-164	Packing nut
6	54-5458	2100 Trigger kit
7	20-5285-5	O-ring (5-pack)
8	54-750-5	Spring (5-pack)
9	54-1236	Air valve stem assembly
10	SGK-457	Air adjustment valve
11	54-768	Air connection
12	—	Air nozzle
13	54-918-5	Gasket (5-pack)
14	—	Fluid nozzle
15	—	Fluid needle
16	54-1347-5	Spring (5-pack)
17	54-1007	Control screw
—	6-229	Gun repair kit
—	77-2895	Part sheet

Nozzle and Needle Selection Chart

Type of Field to be Sprayed	Part Number	Type	CFM at			Max. Pattern at 8"	Fluid Nozzle	Air Nozzle	Fluid Needle Numbers
			30 PSI	50 PSI	70 PSI				
VERY THIN 14-16 secs. Zahn 2 Cup wash primers, dyes, stains, solvents, water, inks THIN 16-20 secs. No. 2 Zahn sealers, primers, lacquers, inks, lubricants, zinc chromates, acrylics	2100-2800-7	PE	9	14.3	20	14	45-6321 (63BSS)	46-6002 (63PB)	47-56310 (563A)
	2100-4307-5	SE	3.4	5.0	—	9	45-6601 (66SS)	46-6018 (66S)	47-56500 (565)
	2100-4307-9	SE	7.9	12.1	—	10.5	45-6601 (66SS)	46-6020 (66SD)	47-56500 (565)
	2100-4308-8	SE	11	15.2	19.5	13	45-6601 (66SS)	46-6082 (66SK)	47-56500 (565)
	2100-4321-1	SE	12	17.3	23	11	45-6601 (66SS)	46-21MD-1	47-56500 (565)
MEDIUM 14-30 secs. No. 2 Zahn lacquers, syn. enamels, varnishes, shellacs, fillers, primers, epoxies, urethanes, lubricants, wax emulsions	2100-4321-2	SE	15.2	22.2	29.6	13	45-6601 (66SS)	46-21MD-2	47-56500 (565)
	—	SE	12.5*	18.3*	24.4*	13	45-6701 (67SS)*	46-21MD-2	45-56700 (567)*
	2100-2821-3	PE	11.6	16.6	22.2	16	45-6321 (63BSS)	46-21MD-3	47-56310 (563A)
VERY HEAVY texture coatings, road marking paint	2100-5111-5	PE	9.5	14.1	19.1	12	45-6801 (68SS)	46-6032 (68PB)	47-56800 (568)
ADHESIVES waterbase white vinyl glues, solvent base, neoprenes (contact cement)	2100-2808-2	PE	7.9	12.1	16.2	4	45-6321 (63BSS)	46-6092 (66SD-3)	47-56310 (563A)
	2100-4308-2	PE	9.5	14.2	19.0	10	45-6601 (66SS)	46-6092 (66SD-3)	47-56500 (565)
ZINC RICH COATINGS	2100-4909-5	PE	9.5	14.1	19.1	12	45-6702 (67VT)	46-6026 (67PB)	47-56702 (567VT)
TEFLONS	2100-4307-9	SE	7.9	12.1	—	7	45-6601 (66SS)	46-6020 (66SD)	47-56500 (565)
HAMMERS	2100-4307-9	SE	7.9	12.1	—	7	45-6601 (66SS)	46-6020 (66SD)	47-56500 (565)

NOTE: PE – Pressure External SE – Siphon External PI – Pressure Internal
*To spray at the CFM's noted above, use a 45-6701 fluid nozzle and a 45-56700 fluid needle along with the standard 46-21MD-2 air nozzle.



195 Internationale Blvd.
Glendale Heights, IL 60139

800-99-BINKS (800-992-4657)

www.binks.com

©2008 ITW Industrial Finishing

A54-75 Printed in U.S.A. 10/08