

INSTRUCTIONS-PARTS LIST

This manual contains **IMPORTANT INSTRUCTIONS** and **WARNINGS**.
READ AND RETAIN FOR REFERENCE



307-623

Rev E
Supersedes D

VISCOUNT® I 3000 PUMP

1000 psi (70 bar) MAXIMUM HYDRAULIC INPUT PRESSURE
3000 psi (210 bar) MAXIMUM FLUID OUTLET PRESSURE

Model 221-080, Series A

With a Severe-Duty Displacement Pump*

*Severe-Duty Displacement Pumps have an abrasion- and corrosion-resistant displacement rod and cylinder. See the **TECHNICAL DATA**, Wetted Parts, on the back cover for further information.

U.S. Patent No. 4,383, 475
Patent 1984 Canada
Brevete 1984
Foreign Patents Pending

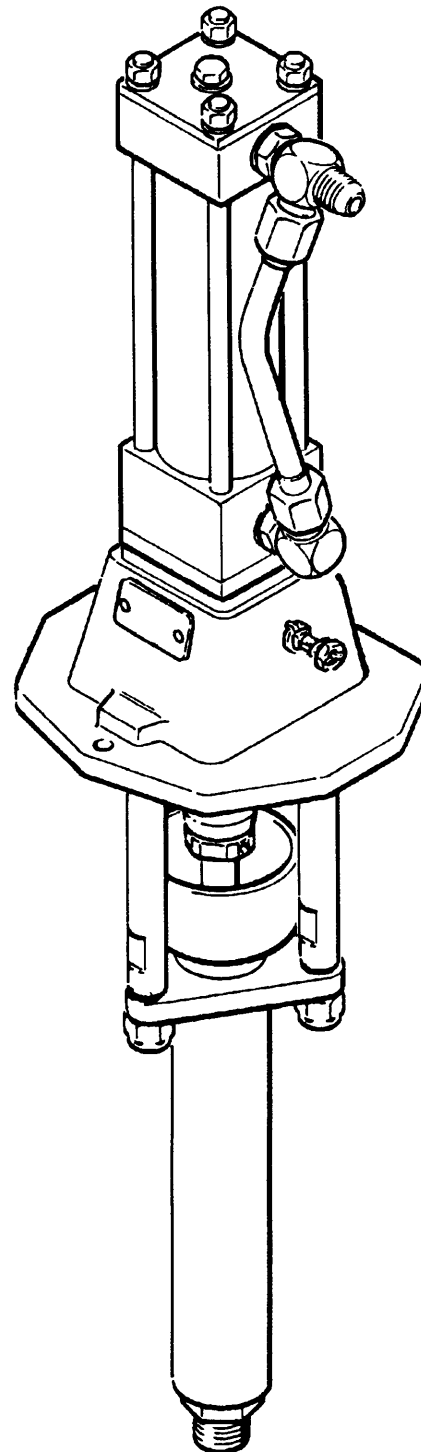

CONTENTS

Warnings	2, 3
Installation	4
Operation	5
Maintenance	5
Service	6
Troubleshooting	6
Repair	6-8
Parts List & Drawing	
Displacement Pump 217-528	9
Pump Model 218-075	10
Accessories	11
Dimensional Drawing	11
Mounting Hole Layout	11
Technical Data	Back Cover
Warranty	Back Cover

WARNINGS

**HIGH PRESSURE SPRAY CAN CAUSE SERIOUS INJURY.
FOR PROFESSIONAL USE ONLY. OBSERVE ALL WARNINGS.**

Read and understand all instruction manuals before operating equipment.

FLUID INJECTION HAZARD

General Safety

The hydraulic reciprocator and pump can generate high fluid pressure. Spray from leaks or ruptured components can inject fluid through your skin and into your body and cause extremely serious bodily injury, including the need for amputation. Also, fluid injected or splashed into the eyes or on the skin can cause severe damage.

NEVER point the dispense valve at anyone or at any part of the body. NEVER put hand or fingers over the nozzle.

ALWAYS follow the **Pressure Relief Procedure**, right, before cleaning or removing the dispense valve nozzle or servicing any system equipment.

NEVER try to stop or deflect leaks with your hand or body.

CHECK operation of all equipment safety devices before each use.

Medical Alert--Airless Spray Wounds

If any fluid appears to penetrate your skin, get **EMERGENCY MEDICAL CARE AT ONCE. DO NOT TREAT AS A SIMPLE CUT.** Tell the doctor exactly what fluid was injected.

Note to Physician: Injection into the skin is a traumatic injury. **It is important to treat the injury surgically as soon as possible.** Do not delay treatment to research toxicity. Toxicity is a concern with some exotic coatings injected directly into the blood stream. Consultation with a plastic surgeon or reconstructive hand surgeon may be advisable.

Spray Gun and Dispensing Valve Safety Devices

Be sure all gun safety devices are operating properly before each use. Do not remove or modify any part of the gun; this can cause a malfunction and result in serious bodily injury.

Safety Latch

Whenever you stop spraying, even for a moment, always set the gun safety latch in the closed or "safe" position, making the gun inoperative. Failure to set the safety latch can result in accidental triggering of the gun.

Trigger Guard

NEVER operate the gun with the trigger guard removed. The trigger guard reduces the risk of accidentally triggering the gun if it is dropped or bumped.

Diffuser (on Spray Guns)

The gun diffuser breaks up spray and reduces the risk of fluid injection when the tip is not installed. Check diffuser operation regularly. Follow the **Pressure Relief Procedure**, below, then remove the spray tip. Aim the gun into a metal pail, holding the gun firmly to the pail. Using the lowest possible pressure, trigger the gun. If the fluid emitted is **not** diffused into an irregular stream, replace the diffuser immediately.

Tip Guard (on Spray Guns)

ALWAYS have the tip guard in place on the spray gun while spraying. The tip guard alerts you to the fluid injection hazard and helps reduce, but does not prevent, accidentally placing your fingers or any part of your body close to the spray tip.

Spray Tip and Nozzle Safety

Use extreme caution when cleaning or changing spray tips or nozzles. If the spray tip or nozzle clogs while spraying, engage the gun safety latch immediately. ALWAYS follow the **Pressure Relief Procedure**, below, and then remove the spray tip or nozzle to clean it.

Pressure

Pressure Relief Procedure

To reduce the risk of serious bodily injury, including fluid injection, injury from moving parts, and splashing in the eyes or on the skin, always follow this procedure whenever you shut off the pump, when checking or servicing any part of the spray system, when installing, cleaning or changing dispense valve nozzles, and whenever you stop dispensing.

- 1 Engage the spray gun or dispensing valve safety latch.
- 2 Close the supply line shutoff valve, and then the return line shutoff valve. Shut off the hydraulic power supply.
- 3 Disengage the gun safety latch. Hold a metal part of the gun or valve firmly to a grounded metal waste pail and trigger it to relieve the fluid pressure.
- 4 Engage the spray gun or dispensing valve safety latch.
- 5 Open the pump outlet drain valve, having a container ready to catch the drainage.
- 6 Leave the drain valve open until you are ready to spray again.

If you suspect that the dispense valve nozzle or hose is completely clogged, or that pressure has not been fully relieved after following the steps above, VERY SLOWLY loosen the tip guard retaining nut or hose end coupling to relieve pressure gradually, then loosen completely. Now clear the obstruction.

MOVINGPARTSHAZARD

Moving parts can pinch or amputate your fingers or other body parts. KEEP CLEAR of moving parts when starting or operating the pump. Follow the **Pressure Relief Procedure** on above before checking or servicing the pump to prevent it from starting accidentally.

EQUIPMENT MISUSE HAZARD

General Safety

Any misuse of the dispensing equipment or accessories, such as overpressurizing, modifying parts, using incompatible chemicals and fluids, or using worn or damaged parts, can cause them to rupture and result in injection or other serious bodily injury, fire, explosion or property damage.

NEVER alter or modify any part of this equipment; doing so could cause it to malfunction.

CHECK all spray equipment regularly and repair or replace worn or damaged parts immediately.

ALWAYS read and follow the fluid and solvent manufacturer's recommendations regarding the use of protective eyewear, clothing and equipment, including respirators.

HOSE SAFETY

High pressure fluid in the hydraulic hoses and pump fluid outlet hoses can be very dangerous. If a hose develops a leak, split or rupture due to any kind of wear, damage or misuse, the high pressure spray emitted from it can cause a fluid injection injury or other serious bodily injury or property damage.

ALL FLUID SPRAY HOSES MUST HAVE SPRING GUARDS ON BOTH ENDS! The spring guards help protect the hose from kinks or bends at or close to the coupling which can result in hose rupture.

TIGHTEN all fluid connections securely before each use. High pressure fluid can dislodge a loose coupling or allow high pressure spray to be emitted from the coupling.

FIRE/EXPLOSION HAZARD

Static electricity is created by the high velocity flow of fluid through the reciprocator, pump and hose. If the pump is not properly grounded, sparking may occur, and the system may become hazardous. Sparks from any source can ignite fumes from solvents and the fluid being dispensed, dust particles and other flammable substances, and can cause a fire or explosion and serious bodily injury and property damage. Do not smoke, and do not plug in or unplug any power supply cords in the spray area when there is any chance of igniting vapors still in the air.

If you experience any static sparking or even a slight shock while using this equipment, STOP SPRAYING IMMEDIATELY. Do not use the system again until the problem has been identified and corrected.

Grounding

To reduce the risk of static sparking, ground the pump. CHECK your local electrical code for detailed grounding instructions for your area and type of equipment.

- Pump:** use ground wire and clamp as shown to the right.
- Hydraulic Hoses and Fluid Outlet Hoses:** use only electrically conductive hoses. Refer also to **HOSE SAFETY** above.
- Hydraulic Power Supply and Air Compressor:** follow manufacturer's recommendations.
- Spray gun:** obtain grounding through connection to a properly grounded fluid hose and pump.
- Fluid supply container;** according to local code.
- Object being sprayed:** according to local code.
- Any pails used when flushing:** Use only metal, grounded pails when flushing. Make firm metal-to-metal contact between the a metal pan of the spray gun and the pail. Use the lowest possible pressure.

Fluid Compatibility

BE SURE that all fluids and solvents used are chemically compatible with the **wetted parts** shown in the **TECHNICAL DATA** shown on page 12. Always read the fluid and solvent manufacturer's literature before using them in your system.

System Pressure

The maximum hydraulic input pressure for this reciprocator is 1000 psi (70 bar). The maximum fluid outlet pressure is 3000 psi (210 bar). Be sure that any components added to the reciprocator power supply side are rated to withstand this pressure.

Consult your separate pump instruction manual for the maximum working pressure of the complete pump.

NEVER use a damaged hose. Before each use, check entire hose for cuts, leaks, abrasion, bulging cover, or damage or movement of the hose couplings. If any of these conditions exist, replace the hose immediately. DO NOT recouple high pressure hose. Never use **tape** or any device to try to mend the hoses; it cannot contain the high pressure fluid.

HANDLE AND ROUTE HOSES CAREFULLY. Do not pull on hoses to move equipment. Do not use fluids or solvents which are not compatible with the inner tube and cover of the hose. DO NOT expose **Graco** hose to temperatures above **180°F (82°C)** or below **-40°F (-40°C)**.

- To maintain grounding continuity when flushing or relieving pressure, always hold a metal part of the gun firmly to the side of a metal pail, and then open the spray gun.*

To ground the pump, loosen the grounding lug locknut (W) and washer (X). Insert one end of a 12 ga (1.5 mm 2) minimum ground wire (Y) into the slot in lug (Z) and tighten the locknut securely. Connect the other end of the wire to a true earth ground. Refer to page 11 to order a ground wire and clamp.

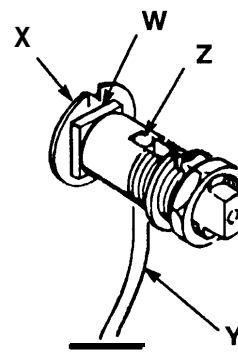

Fig 1

Flushing Safety

Reduce the risk of fluid injection injury, static sparking, or splashing by following the specific flushing procedure given on page 5. Be sure to relieve pressure and then remove the spray tip before flushing. Hold a metal pan of the gun firmly to the side of a grounded metal pail and use the lowest possible fluid pressure during flushing.

IMPORTANT

United States Government safety standards have been adopted under the Occupational Safety and Health Act. These standards—particularly the General Standards, Part 191 O—should be consulted.

INSTALLATION

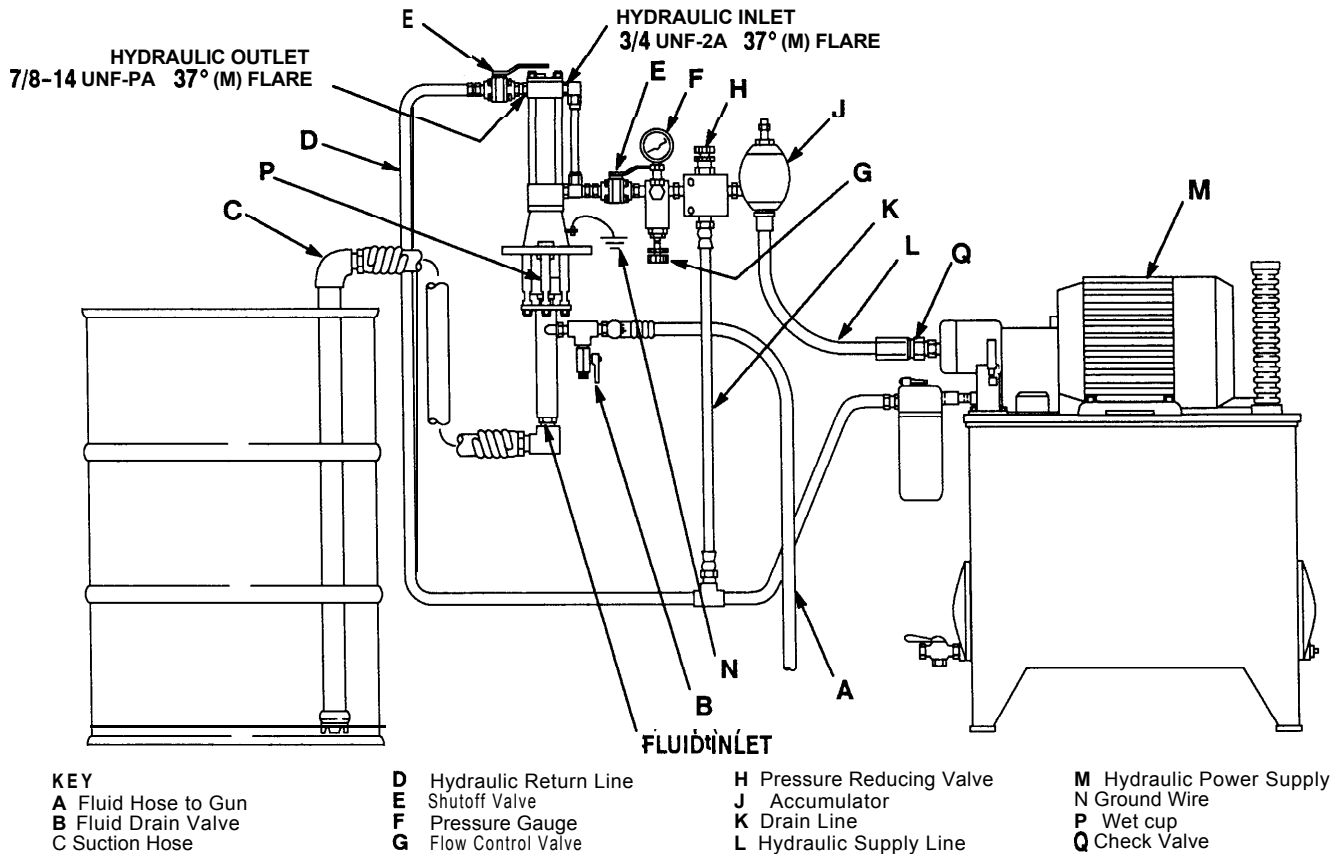

Fig 2

CAUTION

Keep the hydraulic system clean

To reduce the risk of damaging the hydraulic power supply, blow out all hydraulic lines with air, flush thoroughly with solvent, and then blow out with air again before connecting the lines to the reciprocator.

Always plug the hydraulic inlets, outlets and lines when disconnecting them to avoid introducing dirt and other contaminants into the system.

Carefully follow the manufacturer's recommendations on reservoir and filter cleaning, and periodic changes of hydraulic fluid.

CAUTION

Recommended Hydraulic Oil:

Use Graco-approved Hydraulic Oil or the equivalent. The equivalent is a premium, ISO grade 46 petroleum-based hydraulic oil containing rust and oxidation inhibitors and anti-wear agents. See **ACCESSORIES** on page 11.

Before using any other type of oil in this Graco reciprocator, contact Graco Product Service, 1-800-328-0211. Unauthorized use of lesser grade oil or substitutes may void the warranty.

The Typical Installation shown above is only representative. Contact your Graco distributor for specific information. Graco mounting accessories and the pump dimensions and mounting hole layout are shown on page 11.

Hydraulic Power Supply

Be sure that the hydraulic power supply is equipped with a suction filter to the hydraulic pump and a system return line filter of 10 micron size. Carefully follow the manufacturer's recommendations on reservoir and filter cleaning, and periodic changes of hydraulic fluid.

Hydraulic Lines

Supply Line (L): Connect a 1/2 in. minimum ID to the 3/4-16 UNF-2a, 37° male flare inlet of the reciprocator.

Return line (D): Connect a 5/8 in. minimum ID to the 7/8-14 UNF-2a, 37° male flare outlet of the reciprocator.

On the hydraulic supply line (L), install the following accessories:

- A shutoff valve (E) to isolate the system for servicing.
- A fluid pressure gauge (F) to monitor the hydraulic oil pressure to the reciprocator and avoid overpressurizing the reciprocator or displacement pump
- A pressure- and temperature-compensated flow control valve (G) to prevent the reciprocator from running too fast.
- A pressure-reducing valve (H) with a drain line (K) running directly into the hydraulic return line.
- An accumulator (J) to reduce the hammering effect caused by the reciprocator reversing direction.

On the hydraulic return line (D), install a shutoff valve (E) for isolating the reciprocator for servicing.

INSTALLATION

WARNING

To reduce the risk of serious bodily injury, including fluid injection, your system must include a drain valve installed near the pump fluid outlet to help relieve fluid pressure in the displacement pump and hoses when shutting off the pump. See Fig 2.

Install a fluid drain valve (B) and a grounded dispense hose (A) to the 3/8 npt fluid outlet on the displacement pump. Connect a suction hose to the 3/4 npt pump fluid intake. See Fig 2.

Grounding

Ground the pump and system as described on page 3.

OPERATION

WARNING

Do not overpressurize the system

To reduce the risk of overpressurizing the system, which could result in serious bodily injury, including fluid injection:

- NEVER exceed the maximum working pressure of the lowest rated accessory in your system (hydraulic input or fluid output), or the stated maximum working pressures of this pump.
- Regulate the hydraulic input and fluid output pressures, as appropriate, to maintain safe working pressures.

Before you start the pump, check the hydraulic fluid level, and add fluid as necessary to fill the lines.

Flush the pump before using it for the first time to remove the light oil which was left in after factory test. Be sure the solvent used is compatible with the fluid to be sprayed and the wetted parts of the pump.

Fill the displacement pump wet-cup (121) 1/3 full with Graco Throat Seal Liquid or a compatible solvent, to prevent fluid from drying on the displacement rod or damaging the packings. See Fig 3.

WARNING

How to relieve pressure

To reduce the risk of serious bodily injury whenever you shut off the pump, check, service, clean or repair any part of the system, always follow the Pressure Relief Procedure on page 2.

Be sure you ALWAYS shut off the supply line shutoff valve (E) first, and then the return line shutoff valve. This is to prevent overpressurizing the reciprocator or its seals. When starting up the hydraulic system, open the return line shutoff valve first.

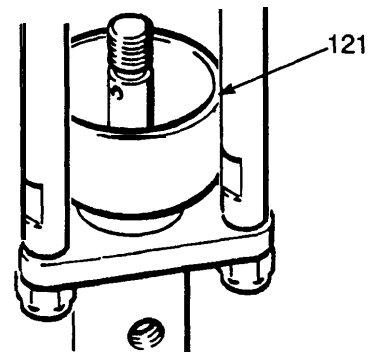

Fig 3

CAUTION

Hydraulic Oil Working Temperature

The recommended hydraulic oil operating temperature is 80 – 115° F (27 – 45° C). The reciprocator seals will wear faster and leakage may occur if the pump is operated at higher oil temperatures.

If the hydraulic oil temperature approaches 130° F (54° C), check the hydraulic fluid supply cooling system, filters, etc. and clean or repair as needed.

WARNING

Be sure the entire system and flushing pails are properly grounded before flushing. Always use the lowest possible pressure, and maintain firm metal-to-metal contact between the gun and pail to reduce the risk of static sparking and splashing.

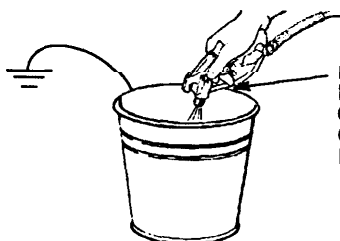

Pump Startup

1. Turn on the hydraulic power supply.
2. Open the return line shutoff valve first, and then open the supply line valve.
3. Slowly open the flow control valve.
4. Use the lowest pressure needed to get good fluid flow or atomization. Higher pressures increase tip wear and pump wear.

In a direct supply system, the pump will start when the gun or valve is opened, and stall when it is closed.

In a circulating system, the pump will operate continuously until the hydraulic power supply is turned off.

MAINTENANCE

Hydraulic leaking at the reciprocator fittings. All of the fittings (7, 8 and 10) going into the upper and lower cylinder caps are self-sealing and have replaceable o-rings. See the Parts Drawing. If you experience any leaking at these fittings, tighten them. If the leaking persists, remove the fitting and replace the worn o-ring.

Check the tightness of the packing nut weekly. Always follow the **Pressure Relief Procedure**, page 2, before adjusting it. The packing nut should be tight enough to stop leakage, but no tighter. Overtightening will compress and damage the packings and result in pump leaking.

Carefully monitor the fluid supply. If the pump empties the supply container, air is sucked into the pump, causing it to run too fast and to be damaged. If the pump runs too fast, shut it off immediately. Fill the supply container and prime the pump and hose to remove all air, or flush the pump and hose with a compatible solvent and leave it filled with an oil-base solvent to protect pump parts from corrosion.

CAUTION

Never leave water-based fluid or air in the pump when it is not in use. Flush the pump and fill it with mineral spirits or other oil-based solvent to prevent pump corrosion or fluid hardening in it.

TROUBLESHOOTING GUIDE

WARNING

To reduce the risk of serious bodily injury, including fluid injection, injury from moving parts, and splashing in the eyes or on the skin, always follow the **Pressure Relief Procedure** on page 2 whenever you shut off the pump, check, service, clean or repair any part of the system.

- 1 Stop pump immediately if it is running too fast; check fluid supply. If empty, refill and reprime the pump; eliminate all air from system. Or flush the pump and store with mineral spirits in it.
- 2 Relieve pressure. Disconnect fluid line. If pump starts when hydraulic power is restored, the hydraulic line, valves, filters, etc are clogged.
- 3 Always stop the pump at the bottom of its stroke and keep the packing nut 1/3 full with TSL.

PROBLEM	CAUSE	SOLUTION
Pump operates, but output low on both strokes	Restricted lines or inadequate hydraulic supply.	Clear lines; increase hydraulic supply.
	Insufficient hydraulic pressure; closed or clogged valves, etc.	Open; clean.
	Exhausted fluid supply.	Refill and reprime, or flush.
	Clogged fluid line, valves, etc.	Clear ² .
	Packing nut too tight.	Loosen.
	Loose packing nut or worn packings.	Tighten; replace.
Pump operates, but output low on down stroke	Held open or worn intake valve.	Clear; service.
Pump operates, but low on up stroke	Held open or worn piston or packings.	Clear; service.
Erratic pump operation	Exhausted fluid supply.	Refill and reprime, or flush ¹
	Held open or worn intake valve or piston packings.	Clear; service.
	Excessive hydraulic fluid supply volume.	Lower.
	Air entrained in fluid.	Purge all air; change fluid.
Pump fails to operate	Restricted lines or inadequate hydraulic supply.	Clear; increase.
	Insufficient hydraulic pressure: closed or clogged valves, etc.	Open; clean.
	Exhausted fluid supply.	Refill and reprime, or flush.
	Clogged fluid line, valves, etc.	Clear ² .
	Damaged hydraulic reciprocator.	Service; see manual 307-654.
	Dried fluid seizure of displacement pump.	Service ³ .

NOTE:

1. Packing Repair 220-397 is available. Use all the parts in the kit for best results, even if the old ones still look good.
2. An asterisk behind a reference number in the text, for example (114*), indicates that the part is included in the repair kit.
3. Clean all parts of the pump as you disassemble them and inspect them for wear or damage. Replace parts as necessary. Use a high grade, lithium-base lubricant when lubrication is specified. Use Loctite® Grade CV thread sealant when thread sealant is specified.

Removing the Displacement Pump (See Fig 4)

1. Flush the pump if possible. Follow the **Press&eke-
lief Procedure Warning**, on page 2. Stop the pump at the bottom of its stroke.
2. Disconnect all hoses from the displacement pump.
3. If you remove the pump from its mounting, disconnect the hydraulic hoses first, and plug all hydraulic connections and lines to prevent contamination.
4. Remove the pin (17) from the top of the displacement rod (115).
5. Unscrew and remove the three tie rod locknuts (15).
6. Unscrew the displacement rod (115) from the reciprocator connecting rod and pull the pump off.
7. **See Displacement Pump Repair** on page 8.

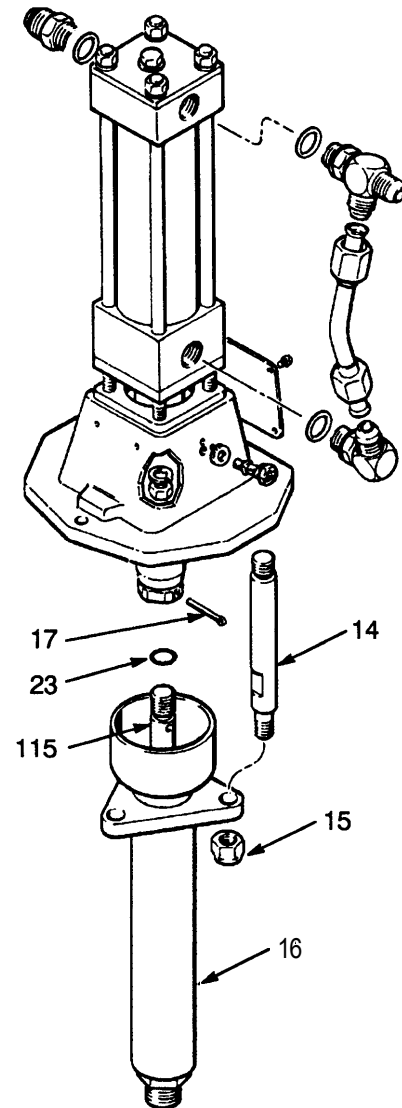

Fig 4

DISPLACEMENT PUMP REPAIR

Intake Valve (See Fig 5)

1. Unscrew the intake valve housing (119) and remove the ball stop pin (1 IO), retainer (112), o-ring (1 1 1*), ball guide (116) and ball (103*).
2. Reassemble the intake valve with a new o-ring and ball.

Piston, Sleeve or Displacement Rod (See Fig 5)

1. Screw the intake valve housing (119) out of the pump housing (120).
2. Loosen the packing nut/wet-cup (121).
3. Push the displacement rod (115) down until the flats of the piston clear the bottom of the housing.
4. Loosen the piston stud (117) and pull it and the rod out the bottom of the housing.
5. Screw the piston out of the rod and remove the ball, glands, and packing retainer and packings.
6. Inspect the outside of the displacement rod and the smooth inner surface of the sleeve (106) for scoring or other surface defects. A worn or damaged rod or sleeve will cause packings to wear faster and result in pump leakage.
7. To remove the sleeve, pull it out the bottom of the pump housing. If you cannot get it out, contact your nearest Graco Factory Branch or Service Department. Install a new sleeve so the beveled edge is at the bottom of the pump housing.
8. Lubricate the inside of the sleeve (106), the rod (115).
9. Lubricate the new packings and glands and the outside of the piston stud (117). One at a time, stack the packings and glands on the piston stud (117), in the order shown in the PARTS DRAWING on page 9. Be sure the lips of the v-packings face up.
10. Place a new ball (102*) on the seat. Apply thread sealant to the threads of the piston stud (117). Screw the assembly into the displacement rod (115). Torque the piston to 65-75 ft-lb (88-102 N.m).

Throat Packings (See Fig 5)

1. Screw the intake valve (122) out of the pump housing.
2. Remove the piston and displacement rod assembly.
3. Unscrew and remove the packing nut/wet-cup (121). Remove the packings and glands from the cavity of the pump housing.
4. Lubricate the new packings and glands. One at a time, stack the packings and glands in the top of the pump housing (120) in the order shown in the PARTS DRAWING on page 9. Be sure the lips of the v-packings face down.
5. Install and tighten the packing nut just enough to stop leakage, but no tighter.
6. Reconnect the displacement pump to the reciprocator.
7. Fill the packing nut/wet-cup (121) 1/3 full with Graco Throat Seal Liquid or a compatible solvent.
8. Reconnect the ground wire if it was disconnected for servicing the pump.

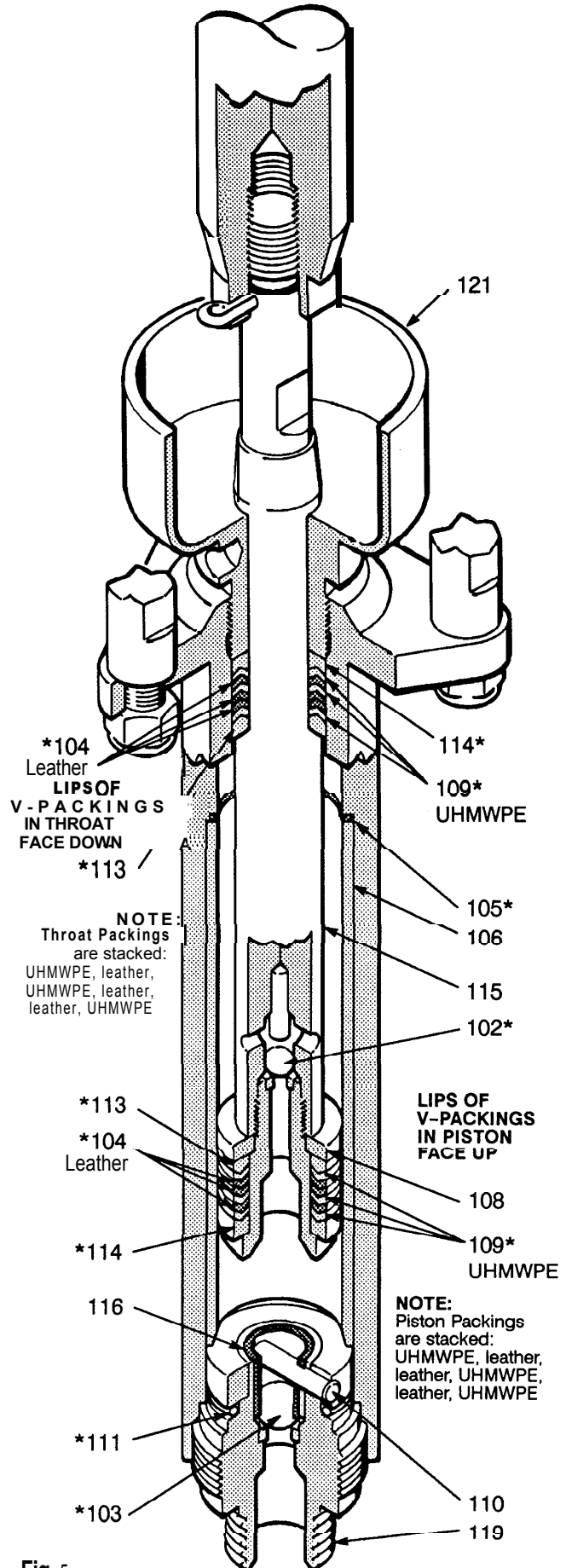

Fig 5

PARTS LIST

PARTS DRAWING

Model 217-528 Displacement Pump Series C, Includes items 101 to 123

REF NO.	PART NO.	DESCRIPTION	QTY
102	101-823*	BALL, stainless steel (piston)	1
103	101-874*	BALL, stainless steel; dia (intake)	1
104	164-477*	V-PACKING; leather	6
105	164-480*	GASKET, flat; PTFE	1
106	178-902**	SLEEVE, housing	1
108	164-484	RETAINER, packing; piston	1
109	108-453*	V-PACKING; UHMWPE	6
110	165-049	PIN, str. headless; ball stop	1
111	165-052*	O-RING; PTFE	1
112	165-279	RETAINER, seal	1
113	183-621*	GLAND, packing; male	2
114	183-622*	GLAND, packing; female	2
115	217-541	DISPLACEMENT ROD	1
116	170-257	GUIDE, ball	1
117	206-345	STUD, piston	1
119	205-981	HOUSING, intake valve	1
120	207-011	HOUSING, disp pump	1
121	207-731	NUT, packing; with lubricant cup	1
122	205-982	FLUID INTAKE VALVE Includes items 103, 110, 111, 112, 116, and 119	1
123	172-479	TAG, warning (not shown)	1

*Included in repair kit 220-397.
Purchase separately.

**Recommended spare parts. Keep on hand
to reduce down time.

SERVICE INFORMATION

Assembly Changed	Part Status	Ref No.	Part No.	Name
221-080 Pump	Old New	16	221-073 218-528	D. Pump D. Pump

NOTE: There is no difference between the old
and new pump.

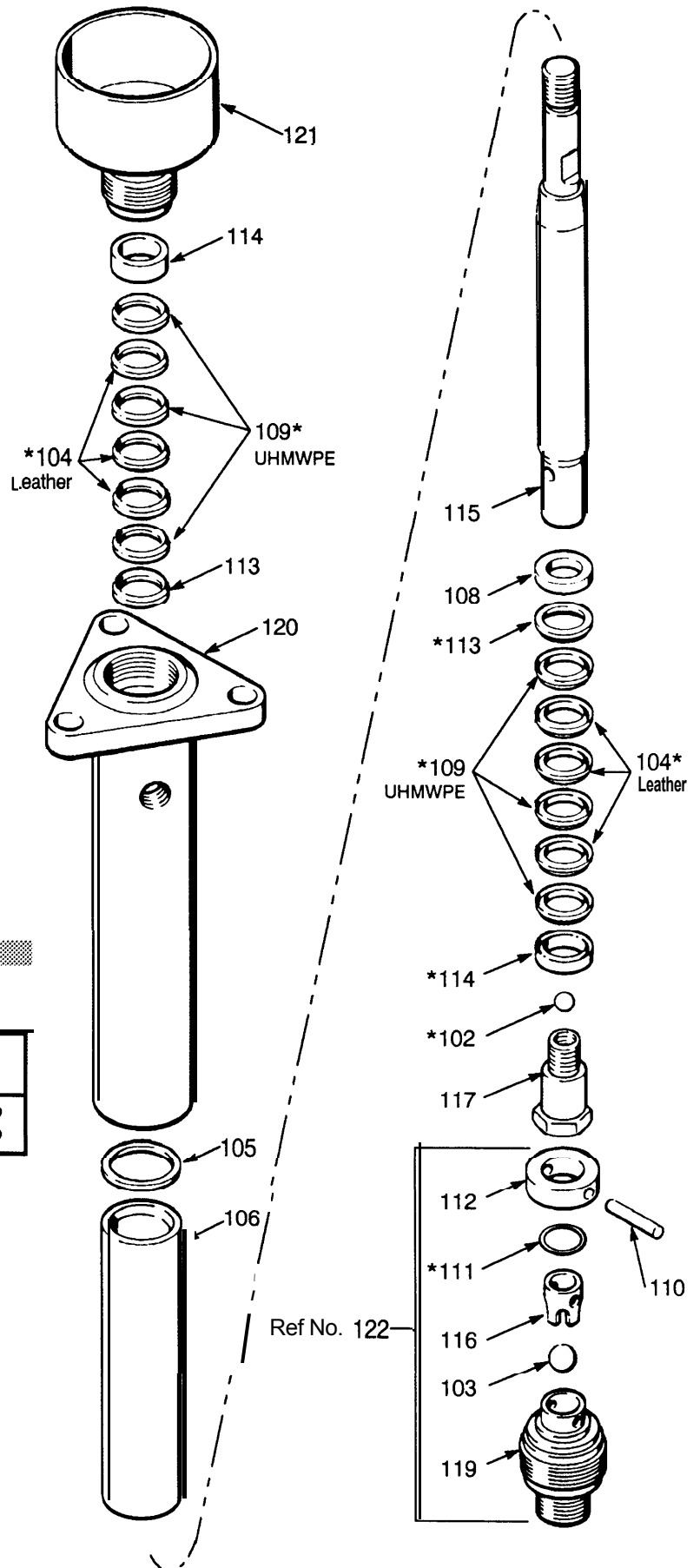

PARTS LIST

PARTS DRAWING

Model 221-080 Viscount I 3000 Pump Series A, Stubby Length

REF	NO.	PART NO.	DESCRIPTION	QTY
	2	100-508	SCREW, mach	4
	3	179-884	PLATE, identification	1
	5	100-133	LOCKWASHER	4
	6	217-222	VISCOUNT I reciprocator See manual 307-654 for parts	1
	7	107-195	ADAPTER, straight thd; 7/8-14 UNF -2a; 37° flare(m) Includes 1 of item 24	1
	8	106-470	ELBOW, straight thd, 3/4-16 UNF -2a; 37° flare includes 1 of item 24	1
	9	217-221	TUBE, inlet, 1/2" ID	1
	10	107-197	TEE, run, straight thd; 3/4-16 UNF -2a; 37° flare(m) Includes 1 of item 24	1
	11	104-029	CLAMP, grounding	1
	12	104-582	WASHER, tab	1
	13	179-882	BASE, reciprocator	1
	14	168-221	ROD, tie; 5-3/4" (146 mm) long	3
	15	102-021	LOCKNUT, hex; 3/8-16 thd size	3
	16	217-528	DISPLACEMENT PUMP See separate parts list on page 9	1
	17	100-103	PIN, cotter	1
	18	106-292	NUT, hex, 3/8"	4
	23	156-082	O-RING	1
	24	110-926	O-RING	3

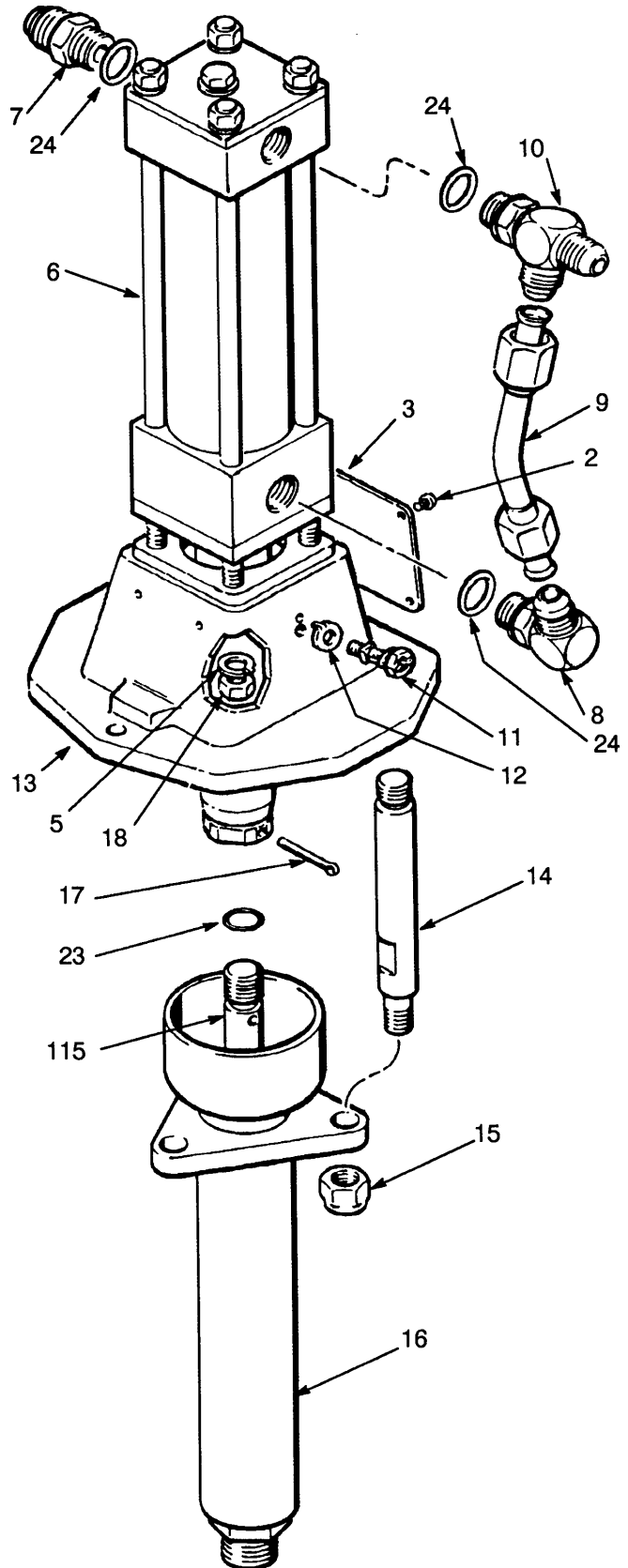

IMPORTANT PHONE NUMBERS

TO PLACE AN ORDER, contact your Graco distributor, or call this number to identify the distributor closest to you: **1-800-328-021 1 Toll Free**

FOR TECHNICAL ASSISTANCE, service repair information or assistance regarding the application of equipment: **1-800-543-0339 Toll Free** Graco

ACCESSORIES

Must be purchased separately

THROAT SEAL LIQUID (TSL)

Non-evaporating liquid for wet-cups
 206-995 1 quart (0.95 liter) size
 206-996 1 gallon (3.8 liter) size

HYDRAULIC SUPPLY AND RETURN HOSE

1500 psi (104 bar) Maximum Working Pressure

For return line; 5/8" ID, coupled 3/4 npt(m) x 7/8"-14
 Sae 37° (f) flare, 90° swivel elbow, grounded

180-091 3 feet (0.9 m) long
 180-092 6 feet (1.9 m) long

For supply line; 1/2" ID, coupled 1/2 npt(m) x 3/4"-16
 Sae 37° (f) flare, 90° swivel elbow, grounded

180-090 3 feet (0.9 m) long
 180-093 6 feet (1.9 m) long

HYDRAULIC SHUTOFF VALVES

102-644 3/4 npt(f) for supply line
 102-645 1" npt(f) for return line

GRACO-APPROVED HYDRAULIC FLUID

169-236 5 gallon (20 liter)
 207-428 1 gallon (3.8 liter)

SUCTION HOSE 214-961

For petroleum base solvent flushing and water base
 fluids. 6 ft (1.8 m) long.

SUCTION TUBE 206-266

55 gallon

Ref No.	Part No.	Description	Qty
1	100-220	THUMBSCREW	1
2	176-684	ADAPTER, bung	1
3	156-591	ELBOW, 90°, 3/4 npt; 1.5"-24 NS	1
4	156-592	TUBE, riser	1
5	156-593	SEAL, o-ring	1
6	159-100	RETAINER, screen	1
7	161-377	SCREEN, filter	1

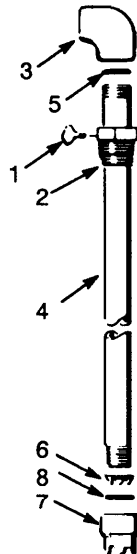

WALL MOUNTING BRACKET 206-221

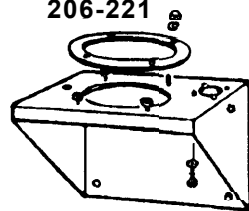

GROUNDING CLAMP 103-358

GROUNDING WIRE 208-950

25 ft (7.6 m) long

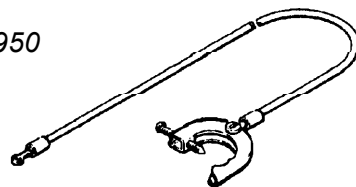

DIMENSIONS

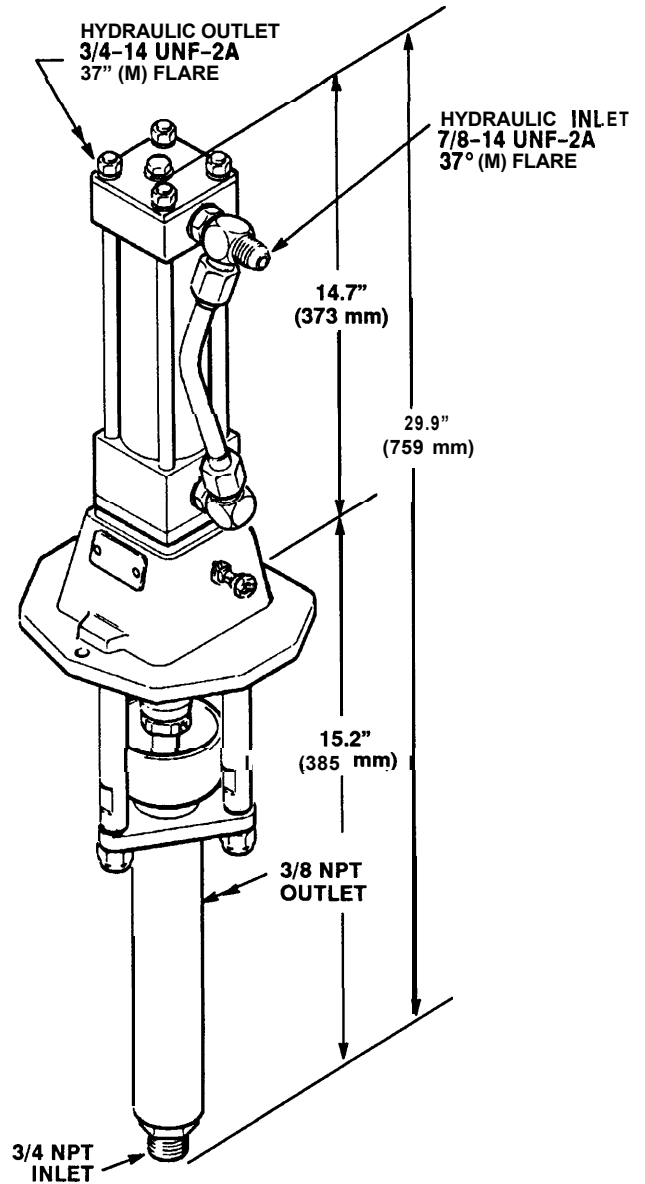

MOTOR MOUNTING DIAGRAM

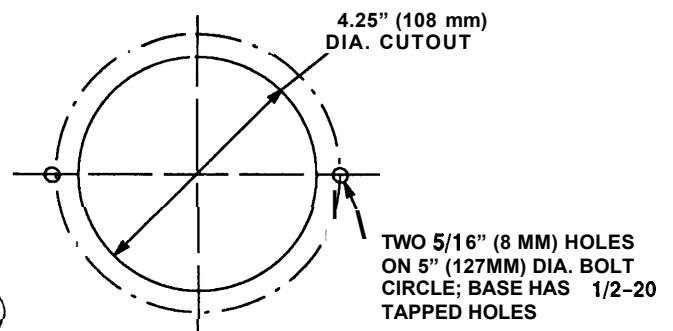

TECHNICAL DATA

Maximum outlet pressure	3000 psi (210 bar)
Fluid delivery rate	5/8 gpm (3 l/min) at 2500 psi (170,bar)
Fluid outlet size	3/8 npt(f)
Fluid inlet size	3/4 npt(m)
Maximum recommended pump speed	40 cycles/min.
Hydraulic fluid consumption	6.5 ounces (0.195 liter) per cycle; or one gallon per 19.5 cycles
Hydraulic input pressure	1000 psi (70 bar) maximum
Hydraulic inlet	3/4-16 UNF-2A, 37 flare(m)
Hydraulic outlet size	7/8-14 UNF-2A, 37 flare(m)
Wetted parts..	Carbon Steel, #440 Stainless Steel (Balls), Hard Chrome Over Stainless Steel (Rod and Sleeve), Ultra High Molecular Weight Polyethylene (UHMWPE) PTFE , Leather
#304 Weight	37 lb (15.75 Kg)

Locktite® is a registered trademark of the Locktite Corporation.

THE GRACO WARRANTY AND DISCLAIMERS

WARRANTY

Graco warrants all equipment manufactured by it and bearing its name to be free from defects in material and workmanship on the date of sale by an authorized Graco distributor to the original purchaser for use. As purchaser's sole remedy for breach of this warranty, Graco will, for a period of twelve months from the date of sale, repair or replace any part of the equipment proven defective. This warranty applies only when the equipment is installed, operated and maintained in accordance with Graco's written recommendations.

This warranty does not cover, and Graco shall not be liable for, any malfunction, damage or wear caused by faulty installation, misapplication, abrasion, corrosion, inadequate or improper maintenance, negligence, accident, tampering, or substitution of non-Graco component parts. Nor shall Graco be liable for malfunction, damage or wear caused by the incompatibility with Graco equipment of structures, accessories, equipment or materials not supplied by Graco, or the improper design, manufacture, installation, operation or maintenance of structures, accessories, equipment or materials not supplied by Graco.

This warranty is conditioned upon the prepaid return of the equipment claimed to be defective to an authorized Graco distributor for verification of the claim. If the claimed defect is verified, Graco will repair or replace free of charge any defective parts. The equipment will be returned to the original purchaser transportation prepaid. If inspection of the equipment does not disclose any defect in material or workmanship, repairs will be made at a reasonable charge, which charges may include the costs of parts, labor and transportation.

DISCLAIMERS AND LIMITATIONS

THE TERMS OF THIS WARRANTY CONSTITUTE PURCHASER'S SOLE AND EXCLUSIVE REMEDY AND ARE IN LIEU OF ANY OTHER WARRANTIES (EXPRESS OR IMPLIED), INCLUDING WARRANTY OF MERCHANTABILITY OR WARRANTY OF FITNESS FOR A PARTICULAR PURPOSE, AND OF ANY NON-CONTRACTUAL LIABILITIES. INCLUDING PRODUCT LIABILITIES, BASED ON NEGLIGENCE OR STRICT LIABILITY. EVERY FORM OF LIABILITY FOR DIRECT, SPECIAL OR CONSEQUENTIAL DAMAGES OR LOSS IS EXPRESSLY EXCLUDED AND DENIED. IN NO CASE SHALL GRACO'S LIABILITY EXCEED THE AMOUNT OF THE PURCHASE PRICE. ANY ACTION FOR BREACH OF WARRANTY MUST BE BROUGHT WITHIN TWO (2) YEARS OF THE DATE OF SALE.

EQUIPMENT NOT COVERED BY GRACO WARRANTY

GRACO MAKES NO WARRANTY, AND DISCLAIMS ALL IMPLIED WARRANTIES OF MERCHANTABILITY AND FITNESS FOR A PARTICULAR PURPOSE, WITH RESPECT TO ACCESSORIES, EQUIPMENT, MATERIALS, OR COMPONENTS SOLD BUT NOT MANUFACTURED BY GRACO. These items sold, but not manufactured by Graco (such as electric reciprocator, switches, hose, etc.) are subject to the warranty, if any, of their manufacturer. Graco will provide purchaser with reasonable assistance in making any claim for breach of these warranties.

Factory Branches: Atlanta, Chicago, Dallas, Detroit, Los Angeles, West Caldwell (N.J.)
Subsidiary and Affiliate Companies: Canada; England; Switzerland; France; Germany; Hong Kong; Japan

GRACO INC. P.O. BOX 1441 MINNEAPOLIS, MN 55440-1441

PRINTED IN U.S.A. 307-623 3-84 Revised 4-90

PARTS CHANGE NOTICE

Some parts in Rev. E of manual 307-623 have changed but have not yet been changed in the instruction manual. Please note the changes below and mark them in your manual or keep this sheet with your manual.

Assembly Changed	Old Part No	Replaced by Part No.	Description
Model 221-080 Viscount Pump, to Series B	217-528	223-587	Displacement Pump <i>Refer to manual 306-981, supplied, for parts and service information.</i>
	110-926	Qty: 1	Part of item 7.
	None	110-987	Qty: 2. Part of items 8 and 10.

REPAIR KIT NOTE: New Displacement Pump 223-587 is PTFE/leather packed. It uses Repair Kit 235-635. To convert to UHMWPE/leather packings, use Repair Kit 223-675.

NOTE: On page 11, change the Wall Mounting Bracket from Part No. 206-221 to Part No. 207-365. Change the Grounding Clamp and Wire from Part Nos. 103-358 and 208-950 to Part No. 222-011.

