

TRITON[®] 3D350HP Diaphragm Pump

311689F

Used to pump waterborne and solvent-based paints and catalysts.

Part No. 253707, Series D

3:1 Ratio Air-Operated Double Diaphragm Pump, with BSPP Fittings

Part No. 253708, Series D

3:1 Ratio Air-Operated Double Diaphragm Pump, with npt Fittings

0.6 MPa, 6 bar (88 psi) Maximum Air Input Pressure

1.8 MPa, 18 bar (260 psi) Maximum Fluid Working Pressure



Important Safety Instructions

Read all warnings and instructions in this manual.
Save these instructions.

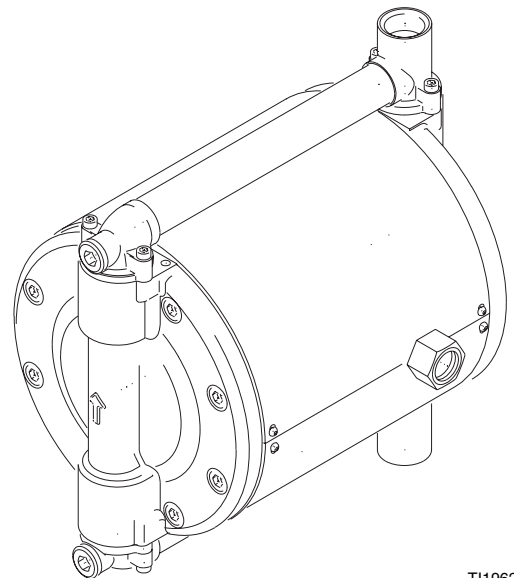





T11962A



Contents

Warning	3
Installation	5
General Information	5
Tighten Threaded Connections	5
Mounting the Pump	6
Air Line	7
Fluid Suction Line	7
Fluid Outlet Line	7
Grounding	9
Operation	10
Pressure Relief Procedure	10
Flush the Pump Before First Use	10
Starting and Adjusting the Pump	10
Pump Shutdown	10
Maintenance	11
Lubrication	11
Flushing and Storage	11
Tighten Threaded Connections	11
Preventive Maintenance Schedule	11
Troubleshooting	12
Repair	14
Prepare the Pump for Repair	14
General Repair Notes	14
Fault Indications	14
Tools Required	14
Replace the Diaphragms	15
Repair the Air Valve	17
Replace the Ball Check Valves	19
Replace the Cylinder and Piston Seals	21
Parts	23
Technical Data	25
Performance Charts	26
Dimensions	27
Wall Mount Hole Pattern	27
Graco Standard Warranty	28
Graco Information	28

The following warnings are for the setup, use, grounding, maintenance, and repair of this equipment. The exclamation point symbol alerts you to a general warning and the hazard symbol refers to procedure-specific risk. Refer back to these warnings. Additional, product-specific warnings may be found throughout the body of this manual where applicable.

 Warning	
	<p>EQUIPMENT MISUSE HAZARD</p> <p>Equipment misuse can cause the equipment to rupture or malfunction and result in serious injury.</p> <ul style="list-style-type: none"> • This equipment is for professional use only. • Read all instruction manuals, tags, and labels before operating the equipment. • Use the equipment only for its intended purpose. If you are not sure, call your Graco distributor. • Do not alter or modify this equipment. Use only genuine Graco parts and accessories. • Check equipment daily. Repair or replace worn or damaged parts immediately. • Do not exceed the maximum working pressure of the lowest rated system component. Refer to the Technical Data on page 25 for the maximum working pressure of this equipment. • Use fluids and solvents which are compatible with the equipment wetted parts. Refer to the Technical Data section of all equipment manuals. Read the fluid and solvent manufacturer's warnings. • Do not use hoses to pull equipment. • Route hoses away from traffic areas, sharp edges, moving parts, and hot surfaces. Do not expose Graco hoses to temperatures above 82°C (180°F) or below -40°C (-40°F). • Wear hearing protection when operating this equipment. • Comply with all applicable local, state, and national fire, electrical, and safety regulations.
	<p>PRESSURIZED EQUIPMENT HAZARD</p> <p>Spray from the gun, hose leaks, or ruptured components can splash fluid in the eyes or on the skin and cause serious injury.</p> <ul style="list-style-type: none"> • Do not point the gun at anyone or at any parts of the body. • Do not stop or deflect leaks with your hand, body, glove, or rag. • Follow the Pressure Relief Procedure on page 10 whenever you are instructed to relieve pressure; stop spraying; clean, check, or repair the equipment; and install or clean the spray nozzle. • Tighten all fluid connections before operating the equipment. • Check the hoses, tubes, and couplings daily. Replace worn, damaged, or loose parts immediately. Permanently coupled hoses cannot be repaired; replace the entire hose.
	<p>FIRE AND EXPLOSION HAZARD</p> <p>Improper grounding, poor ventilation, open flames or sparks can cause a hazardous condition and result in a fire or explosion and serious injury.</p> <ul style="list-style-type: none"> • Ground the equipment and the object being sprayed. Refer to Grounding on page 9. • If there is any static sparking or you feel an electric shock while using this equipment, stop the equipment immediately. Do not use the equipment until you identify and correct the problem. • Provide fresh air ventilation to avoid the buildup of flammable fumes from solvents or the fluid being sprayed. • Keep the work area free of debris, including solvent, rags, and gasoline. • Eliminate all ignition sources such as pilot lights, cigarettes, and static arcs from plastic drop cloths. Do not plug in or unplug power cords or turn lights on or off in the spray area.

 **Warning**



TOXIC FLUID HAZARD

Hazardous fluid or toxic fumes can cause serious injury or death if splashed in the eyes or on the skin, inhaled, or swallowed.

- Know the specific hazards of the fluid you are using.
- Store hazardous fluid in an approved container. Dispose of hazardous fluid according to all local, state and national guidelines.
- Always wear protective eyewear, gloves, clothing and respirator as recommended by the fluid and solvent manufacturer.
- If a diaphragm fails, fluid is exhausted along with the air. When pumping hazardous fluids, place the pump in an appropriate container to catch the fluid if a diaphragm ruptures.



MOVING PARTS HAZARD

Moving parts, such as the diaphragm shaft, can pinch or amputate your fingers.

- Before servicing the equipment, follow the **Pressure Relief Procedure** on page 10 to prevent the equipment from starting unexpectedly.



PERSONAL PROTECTIVE EQUIPMENT

You must wear appropriate protective equipment when operating, servicing, or when in the operating area of the equipment to help protect you from serious injury, including eye injury, inhalation of toxic fumes, burns, and hearing loss. This equipment includes but is not limited to:

- Protective eyewear
- Clothing and respirator as recommended by the fluid and solvent manufacturer
- Gloves
- Hearing protection

Installation

General Information

- FIG. 3 on page 8 is only a guide for installing system components and accessories. It is not an actual system design. Contact your Graco distributor for assistance in designing a system to suit your particular needs.
- Always use Genuine Graco Parts and Accessories, available from your Graco distributor. If you supply your own accessories, be sure they are adequately sized and pressure-rated for your system.
- Reference numbers and letters in parentheses refer to the reference numbers in the figures and the parts list on page 23.

Tighten Threaded Connections

1. Before each use, check all hoses for wear or damage and replace as necessary.
2. Check to be sure all threaded connections are tight and leak-free.
3. Check and re-torque all screws and fasteners at least every two months. Re-torque the fluid cover screws first, followed by the manifold screws. Note: Before using pump, loosen fluid cover screws (31) 1-2 turns and then re-torque to 27 N•m (20 ft-lb).

Mounting the Pump

For ease of operation and service, mount the pump so the air inlet, fluid inlet, and fluid outlet ports are easily accessible. The inlet port must point down and the outlet port must point up.

Use 5/8 in. lag screws or bolts for mounting.

 To ensure proper operation, mount the pump in a horizontal position.

Wall Mount Installation

1. Wall Mount Kit 245875 is available. See FIG. 1.
2. Be sure the wall can support the weight of the pump, bracket, hoses and accessories, as well as the stress caused during operation.
3. Using the wall bracket (B) as a template, drill 5/8 in. mounting holes in the wall. See page 27 for a wall mounting diagram. Mount the bracket 1.2-1.5 m (4-5 ft) above the floor.
4. Attach the bracket (B) to the pump (A) with the screws (C) and washers (D) provided in the kit.
5. Attach the bracket to the wall. Use screws (E) that are long enough to keep the pump from vibrating during operation. Be sure the pump is level.

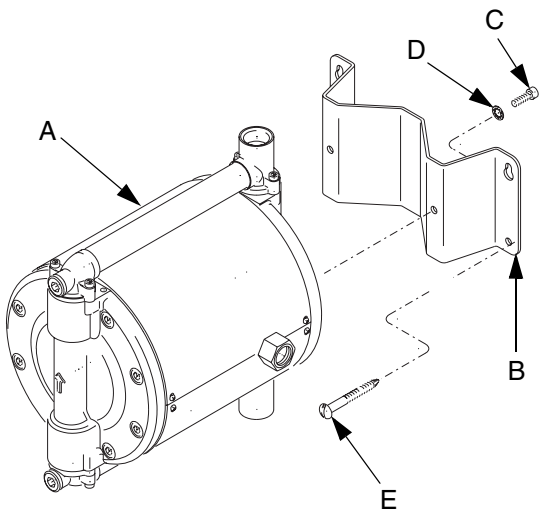

T12079B

FIG. 1: Wall Mount Kit

Floor Stand Installation

Floor Stand Kit 245874 is available. See FIG. 2 to assemble.

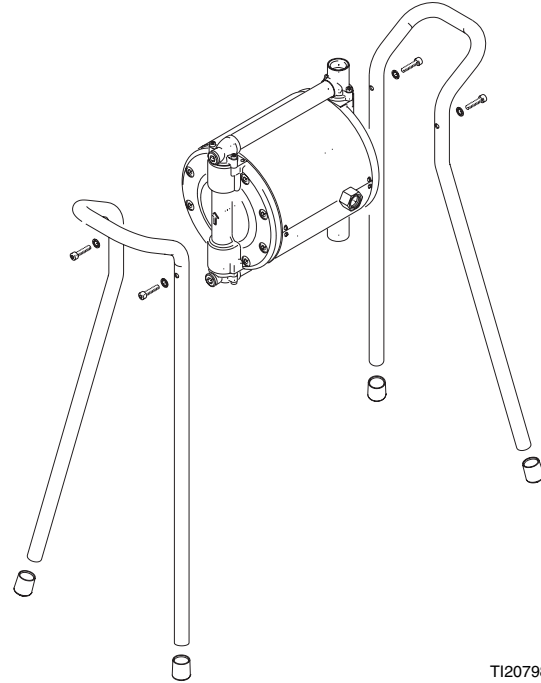

T120798

FIG. 2: Floor Stand Installation

Air Line

1. Install the air line accessories as shown in FIG. 3. Mount these accessories on the wall or on a bracket. Be sure the air line supplying the accessories is grounded.
 - a. Install an air regulator (C) and gauge to control the fluid pressure. The fluid outlet pressure will be three times the setting of the air regulator.
 - b. A bleed-type master air valve (B) is required in your system to relieve air trapped between it and the pump when the valve is closed. Trapped air can cause the pump to cycle unexpectedly which could result in serious injury including splashing in the eyes or on the skin, or injury from moving parts. Be sure the bleed valve is easily accessible from the pump, and is located downstream from the air regulator.
 - c. The air line filter (D) removes harmful dirt and moisture from the compressed air supply.
 - d. A second bleed-type air valve (T) isolates the air line accessories for servicing. Locate upstream from all other air line accessories.
2. Install a grounded, flexible air hose (A) between the accessories and the pump air inlet. See **Technical Data** on page 25 to determine the air inlet size of your pump. Use a minimum 13 mm (1/2 in.) ID air hose.
3. Screw an air line quick disconnect coupler (N) onto the end of the air hose (A), and screw the mating fitting into the pump air inlet snugly. Do not connect the coupler to the fitting until you are ready to operate the pump.

Fluid Suction Line

- Use conductive hoses (E). See FIG. 3.
- See **Technical Data** on page 25 to determine the fluid inlet size of your pump.
- For maximum suction lift (wet and dry) information, see **Technical Data** on page 25.

Fluid Outlet Line

1. Use conductive fluid hoses (J). See FIG. 3. See **Technical Data** on page 25 to determine the fluid outlet size of your pump.
2. Install a fluid drain valve (G) near the fluid outlet. The fluid drain valve is required to relieve pressure in the hose and gun. The drain valve reduces the risk of serious injury, including splashing in the eyes or on the skin, or injury from toxic fluids.
3. Install a shutoff valve (H) in the fluid outlet line.

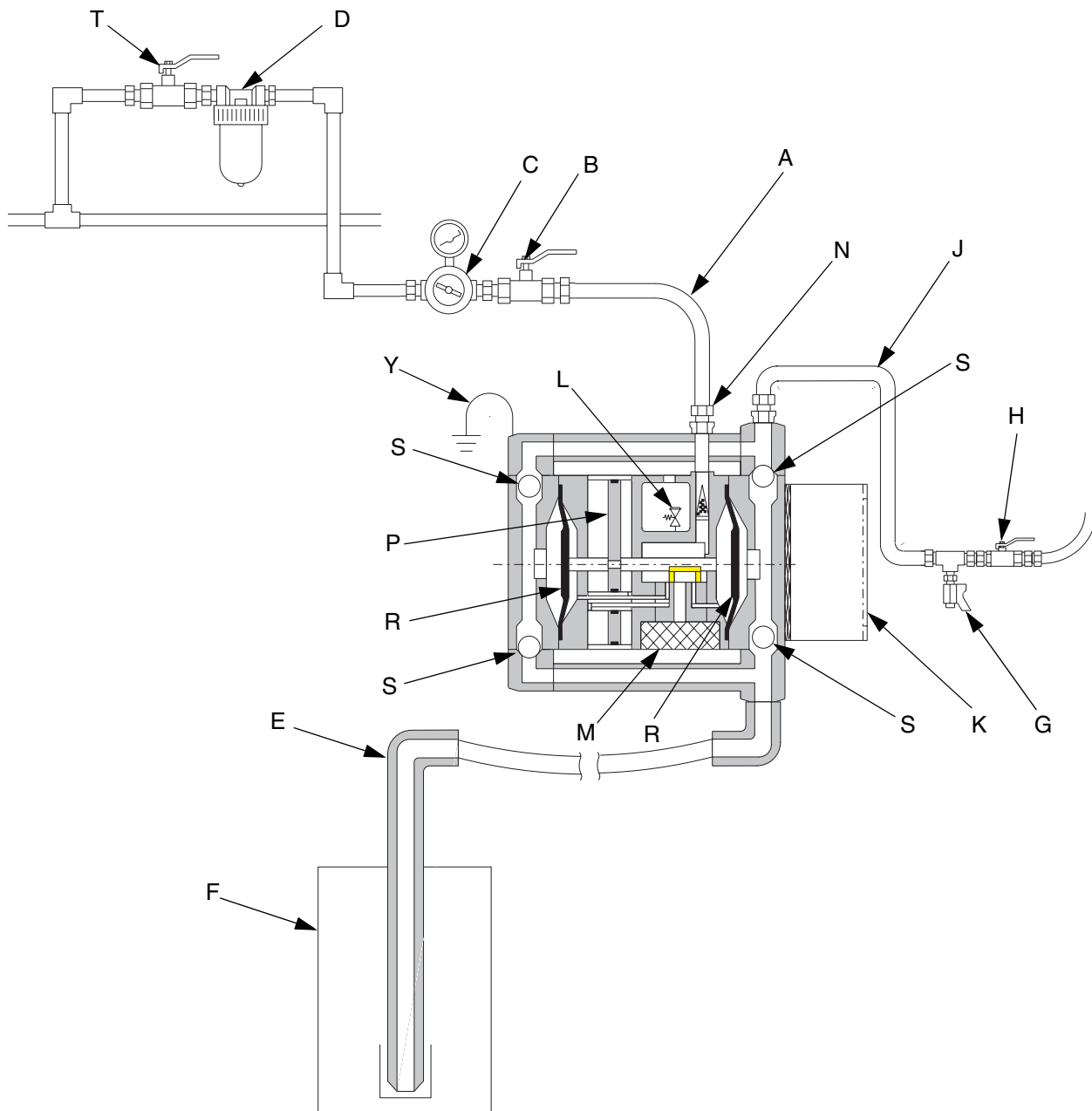

T11961B

Key:

- | | |
|-------------------------------|-------------------------------------|
| A Air Supply Line | K Mounting Bracket |
| B Bleed-Type Master Air Valve | L Internal Air Relief Valve |
| C Air Regulator | M Muffler |
| D Air Line Filter | N Air Line Quick Disconnect Coupler |
| E Fluid Suction Line | P Pump Air Piston |
| F Fluid Supply | R Pump Diaphragms |
| G Fluid Drain Valve | S Pump Ball Checks |
| H Fluid Shutoff Valve | T Air Shutoff Valve |
| J Fluid Line | Y Pump Ground Wire |

FIG. 3. Typical Installation

Grounding

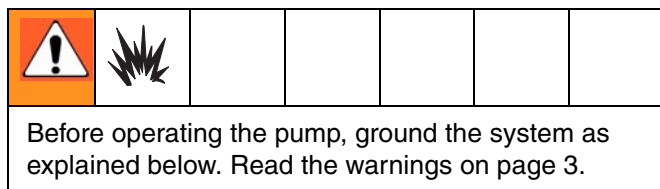

Ground all of this equipment:

- *Pump:* use a ground wire and clamp. See FIG. 4. Loosen the grounding screw (X). Insert one end of a 1.5 mm² (12 ga) minimum ground wire (Y) into the pump's grounding clamp (8) and tighten the screw (X) securely. Connect the other end of the wire to a true earth ground. For a ground wire and clamp, order Part No. 238909.
- *Air and fluid hoses:* Use only electrically conductive hoses.
- *Air compressor:* Follow manufacturer's recommendations.
- *Fluid supply drum:* Follow your local code.
- *All solvent pails used when flushing:* Follow your local code. Use only metal pails, which are conductive, placed on a grounded surface. Do not place the pail on a nonconductive surface, such as paper or cardboard, which interrupts the grounding continuity.

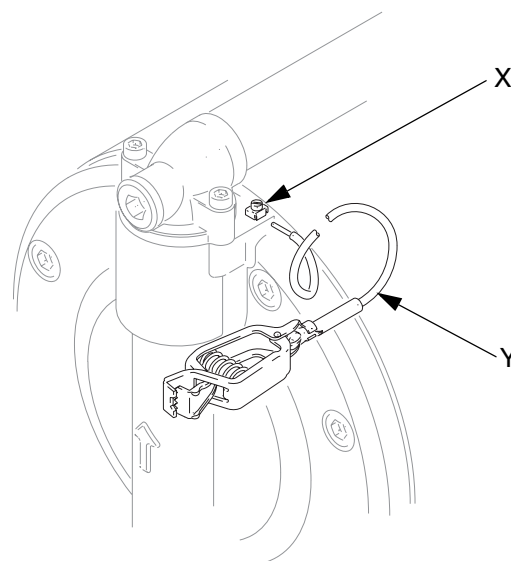





TI2085A

FIG. 4. Grounding the Pump

Operation

Pressure Relief Procedure

						
<p>Read the warnings on page 3, and follow the Pressure Relief procedure below whenever you:</p> <ul style="list-style-type: none"> • are instructed to relieve pressure • stop spraying • check or service any of the equipment • install or clean the fluid nozzle. 						

1. Shut off the air to the pump.
2. Open the dispensing valve, if used.
3. Open the fluid drain valve to relieve all fluid pressure, having a container ready to catch the drainage.

Flush the Pump Before First Use

The pump was tested in oil. If the oil could contaminate the fluid you are pumping, flush the pump thoroughly with a compatible solvent. Follow the steps under **Starting and Adjusting the Pump**.

Starting and Adjusting the Pump

1. Be sure the pump is properly grounded. Refer to **Grounding** on page 9.
2. Check all fittings to be sure they are tight. Be sure to use a compatible liquid thread sealant on all male threads.
3. Re-torque all screws and fasteners before startup. Re-torque the fluid cover screws first, followed by the manifold screws.
4. Place the suction tube (E) in the fluid to be pumped.
5. Place the end of the fluid hose (J), see FIG. 3, into an appropriate container.
6. Close the fluid drain valve (G). Open the fluid shutoff valve (H).

7. With the pump air regulator (C) closed, open the bleed-type master air valve (B).
8. If the fluid hose has a dispensing device, hold it open while continuing with the following step.
9. Slowly open the air regulator (C) until the pump starts to cycle. Allow the pump to cycle slowly until all air is pushed out of the lines and the pump is primed.

If you are flushing, run the pump long enough to thoroughly clean the pump and hoses. Close the air regulator. Remove the suction tube (E) from solvent and place it in the fluid to be pumped.



Operating the pump beyond the maximum air input pressure will decrease diaphragm life.

Do not operate the pump dry for long periods of time to avoid reducing diaphragm life.

Pump Shutdown

Short Term Shutdown

For a short term shutdown, relieve the pressure (see at left).

Long Term Shutdown

For a long term shutdown, such as several hours or overnight:

1. Flush the pump thoroughly.
2. Leave compatible solvent in the pump.
3. Relieve the pressure (see at left).

Maintenance

Lubrication

CAUTION
Lubrication of the pump is not required. Oil is exhausted through the muffler, which could contaminate the fluid supply or other equipment. Excessive lubrication can also cause the pump to malfunction.

Flushing and Storage

Flush the pump with a compatible solvent often enough to prevent the fluid you are pumping from drying in the pump and damaging it. Follow the **Pressure Relief Procedure** on page 10 before storing it for any length of time.

Tighten Threaded Connections

1. Before each use, check all hoses for wear or damage, and replace as necessary.
2. Check to be sure all threaded connections are tight and leak-free.
3. Check and re-torque all screws and fasteners at least every two months. Re-torque the fluid cover screws first, followed by the manifold screws.
NOTE: Before using pump, loosen fluid cover screws (31) 1-2 turns and then re-torque to 27 N•m (20 ft-lb).

Preventive Maintenance Schedule

Establish a preventive maintenance schedule, based on the service history of the pump. This is especially important for prevention of spills or leakage due to diaphragm failure.

Troubleshooting

 Relieve the pressure (page 10) before checking or servicing the equipment.

 Check all possible problems and causes before disassembling the pump.

Problem	Cause	Solution
Pump cycles at stall or fails to hold pressure at stall.	Worn check valve balls (56), seats (53), or ball guides (57).	Replace. See page 19.
Pump will not cycle, or cycles once and stops.	Stuck or dirty air valve.	Disassemble and clean air valve. See page 17. Use filtered air.
	Check valve ball (56) severely worn and wedged in seat (53).	Replace ball and seat. See page 19.
	Check valve ball (56) wedged in seat (53) due to overpressurization.	Replace. See page 19. Do not exceed the maximum fluid working pressure, see page 25.
	Clogged fluid dispensing valve.	Relieve pressure and clear valve.
	Pinched hose line.	Check lines.
Pump operates erratically.	Clogged suction line.	Inspect; clear.
	Sticky or leaking check valves.	Clean or replace balls (56) and seats (53). See page 19.
	Ruptured diaphragm (14).	Replace. See page 15. Do not exceed maximum air input pressure.
	Restricted exhaust.	Remove restriction.
Air bubbles in fluid.	Loose suction line.	Tighten.
	Ruptured diaphragm (14).	Replace. See page 15.
Pump running irregularly. Stroke frequency dropping, coming to standstill.	Worn parts.	Replace worn parts. Check compressed air supply.
	Icing caused by: compressed air too moist, stroke frequency too high, local temperature too low.	Remove ice by changing operating conditions.
Air escapes continually from muffler.	Damaged air valve cup (47) or seat (33).	Replace damaged parts. See page 17.
	Foreign matter inside pump.	Check air filter.
Pump does not start, or pressure fluctuates.	Worn check valve seats (53).	Replace. See page 19.
	Inlet strainer blocked, maximum suction exceeded, hose or seal defective.	Clean strainer. Replace defective parts.
	Contaminated fluid. Pump installed or operated incorrectly.	Check fluid supply. Follow installation and operation instructions in this manual.

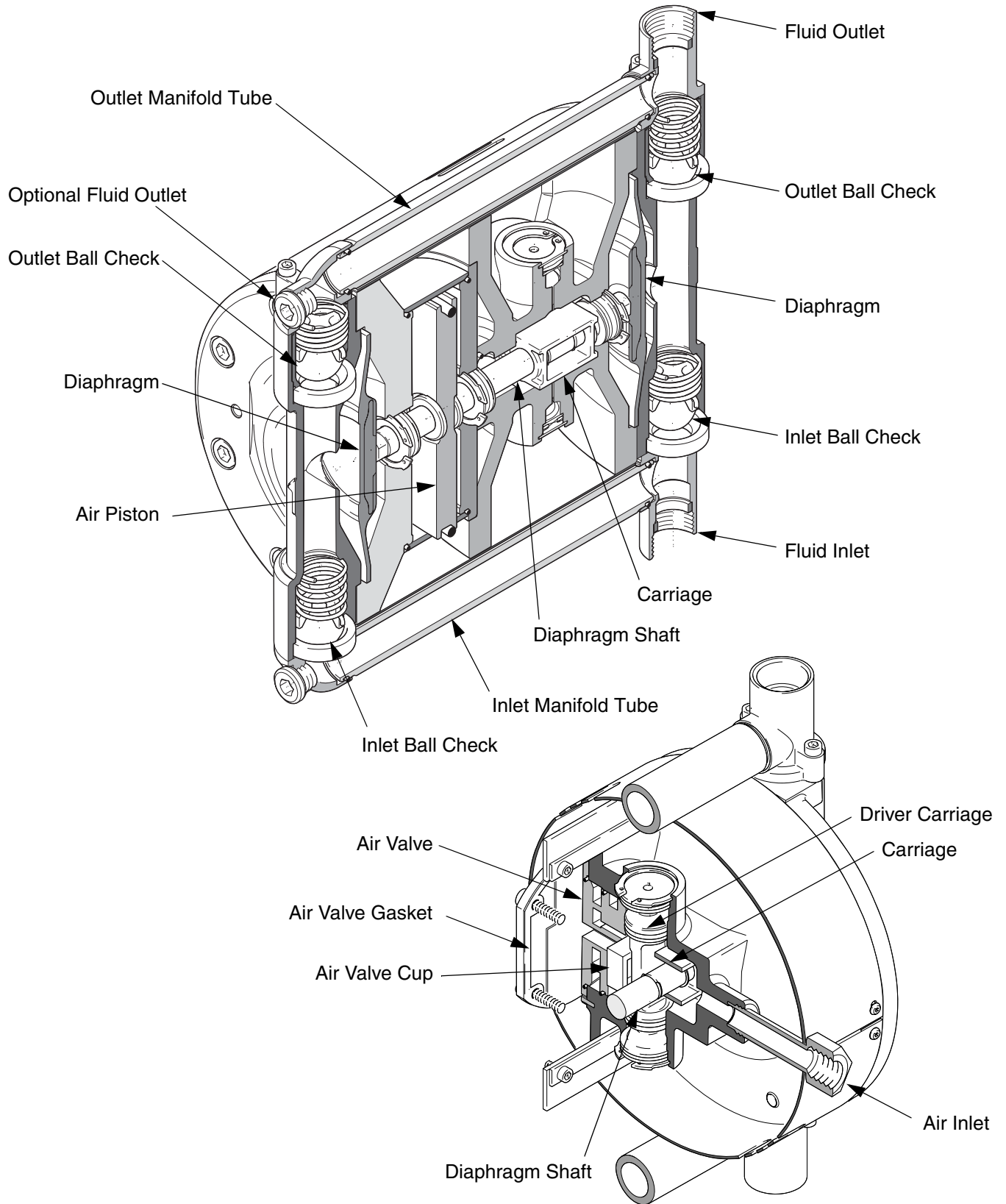
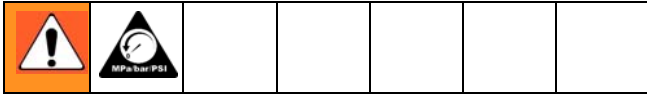

FIG. 5. Cutaway Views of Pump and Air Valve

Repair



Prepare the Pump for Repair

1. Flush the pump if possible, page 11.
2. Relieve the pressure, page 10.
3. Disconnect the air and fluid hoses.
4. Remove the pump from its mounting and take it to the work bench.

General Repair Notes



- A qualified technician should make all repairs.
- Inspect and clean all parts thoroughly before reassembly.
- Use only genuine Graco replacement parts, available from your Graco distributor.
- Be careful not to damage sealing surfaces.
- Replace all o-rings removed from the pump.
- Follow all lubrication, torque, and repair notes in the repair procedures.
- Do not use silicone or silicone-based grease.

Fault Indications

During operation, check for indications of worn or damaged parts, such as:

- major pressure fluctuations
- change in the pump's operating sound
- irregular operation.

Always replace worn or damaged parts immediately to prevent additional damage.

Tools Required

- 4, 5, 6, 8 and 10 mm allen wrenches
- 13 mm open end wrench
- 28 mm open end wrench, or adjustable wrench
- two flat blade screwdrivers
- #2 Phillips screwdriver
- internal snap ring pliers
- dowel rod (wood or plastic)
- o-ring pick
- diaphragm installation tool (part number 261695)

Replace the Diaphragms



Diaphragm Repair Kit 243152 is available. Parts included in the kit are marked, for example (14*). For the best results, replace both diaphragms and all o-rings (13*).

Diaphragm Repair Tool 261695 is available to assist with diaphragm installation.



Operating the pump beyond the maximum air input pressure will decrease diaphragm life.



Do not operate the pump dry for long periods of time to avoid reducing diaphragm life.

Disassembly

1. Prepare the pump for repair, page 14.
 2. Remove the screws (31) from one fluid cover (1). Pull the cover assembly off, separating it from the fluid tubes (12). See FIG. 6.
 3. Remove the fluid tubes (12) from the other cover assembly.
 4. Remove the screws (31) and the remaining fluid cover (1).
 5. Install diaphragm (14) using the diaphragm repair tool to force the shaft all the way to one side. Press the short, wide boss on the tool directly on the diaphragm. The part number on the tool should face away from the pump. See FIG. 6.
 6. Unscrew the opposite diaphragm (14) from the shaft by turning it counterclockwise by hand.
 7. Push the shaft in the opposite direction by installing the diaphragm repair tool on the opposite side of the pump. Press the tall boss on the tool directly on the pump shaft. The part number on the tool should face toward the pump. See FIG. 6.
 8. Unscrew the remaining diaphragm (14) from the shaft by turning it counterclockwise by hand.
2. Depress the first diaphragm (14*) using the diaphragm repair tool and install the opposite diaphragm (14*) by hand.
 3. Remove the o-rings (13) from the fluid tubes (12) and replace with new o-rings (13*) from the kit.
 4. Install the cover assembly that has the tube housings (4) attached. The arrow must point toward the top of the pump and the air inlet (40) must be to the right of the cover (1). Torque the screws (31) to 27 N•m (20 ft-lb).
 5. Lubricate the o-rings (13*) and ends of the fluid tubes (12) and push the tubes into the tube housings (4) so they are securely seated.
 6. Install the cover assembly that has the fluid inlet (3) and outlet (2) housings attached. The arrow must point toward the top of the pump. Seat the cover securely on the fluid tubes (12). Torque the screws (31) oppositely and evenly to 27 N•m (20 ft-lb).

Reassembly

1. While the diaphragm repair tool holds the shaft to one side, screw the new diaphragm (14*) into the shaft by hand. See FIG. 6.

-  Lubricate.
-  Torque to 27 N•m (20 ft-lb)

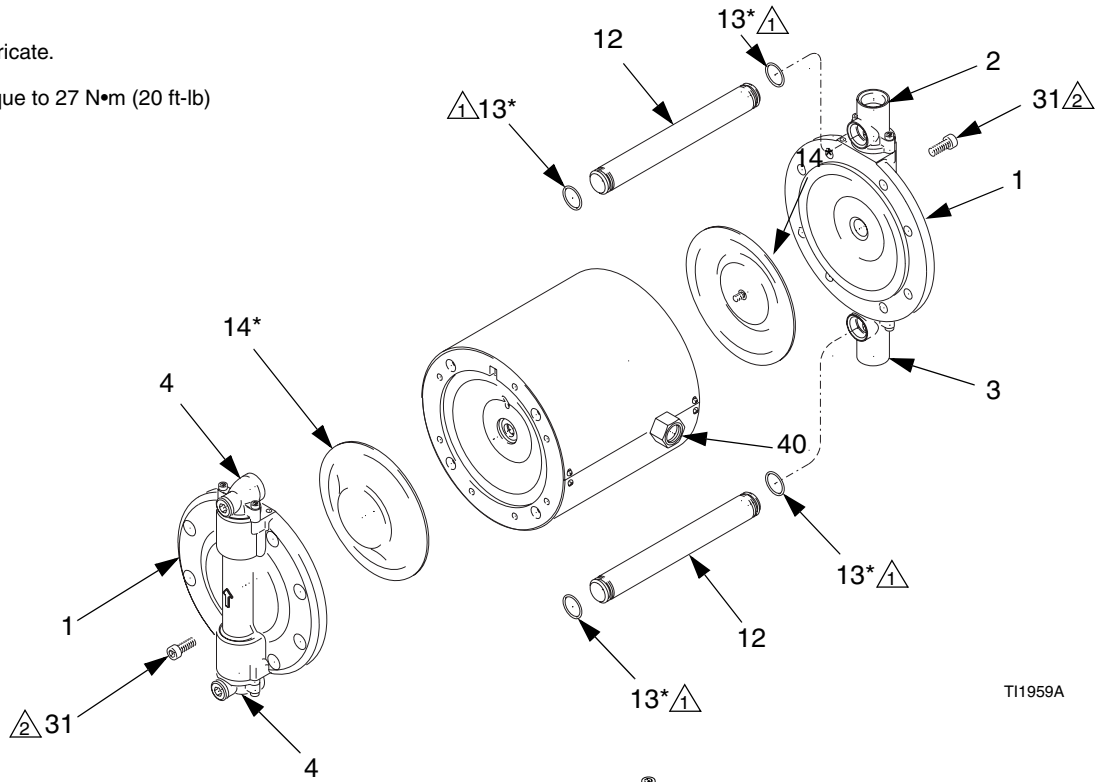

T11959A

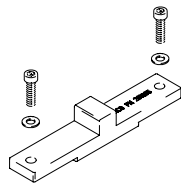

T18632A

Diaphragm Repair Tool 261695

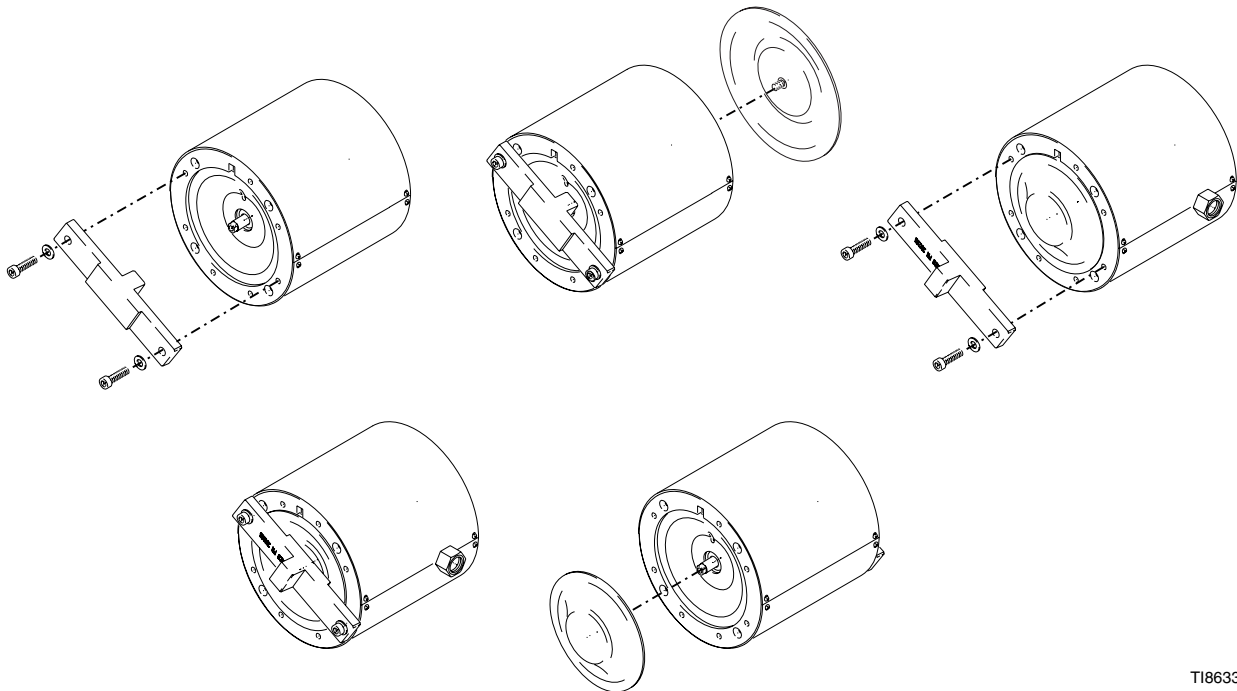

T18633A

FIG. 6. Replace the Diaphragms

Repair the Air Valve

 Air Valve Repair Kit 243153 is available. Parts included in the kit are marked, for example (33†). For the best results, use all parts in the kit.

Disassembly

1. Prepare the pump for repair, page 14.
2. Remove the screws (31) from one fluid cover (1). Pull the cover assembly off, separating it from the fluid tubes (12). See FIG. 7.
3. Remove the screws (31) and the other fluid cover (1) assembly, keeping the fluid tubes (12) attached.
4. Remove the air inlet fitting (40).
5. Remove the screws (68) and the top (67) and bottom (66) covers.
6. Remove the diaphragms (14), page 15.
7. Remove the four screws (38) and washers (37), air valve cover (36), and gasket (35).
8. Pry the air valve seat (33) out of the housing (5), using two screwdrivers inserted in the recesses on the seat. Remove the o-rings (43, 44, and 80) from the seat.
9. Remove the cup (47) from the center housing.
10. Remove the two clips (46) from the shaft (17).
11. Remove the screws (30), cylinder outer cover (11), and cylinder (7). Do not lose the o-rings (22).
12. Pull out the piston (16) and shaft assembly.
13. Remove the screws (29) and inner cover (6).
14. Remove the clips (50) from the air valve plugs (51). Thread a screw (38) partially into each plug and pull the plugs out. Remove the o-rings (52).
15. Push the driver carriage (48) out of its bore. Remove the o-rings (49).
16. Remove the clips (21) and push the bearings (18) out of the center housing (5), inner cover (6), and outer cover (11). Remove the o-rings (19, 20) from the bearings.
17. Remove the carriage (45).

Reassembly

 Lubricate all o-rings when reassembling the pump.

1. Install the o-rings (19†, 20†) on the three bearings (18). Install the bearings in the center housing (5), cylinder inner cover (6), and cylinder outer cover (11). Secure with the clips (21).
2. Install the carriage (45) in the center housing (5), oriented as shown.
3. Install the o-rings (49†) on the driver carriage (48†). Push the driver carriage into its bore, oriented as shown.
4. Install the o-rings (52†) on the air valve plugs (51). Install the plugs and secure with clips (50).
5. Check that the o-rings (42 and 28) are in place in the center housing (5).
6. Check that the o-rings (22 and 25) are in place on the cylinder inner cover (6).
7. Check that the o-ring (23), packing (26), and quad ring (32) are in place on the piston (16).
8. Insert the air valve tube (24) through the cylinder inner cover (6). Install the cover on the center housing (5). Seat the air valve tube securely in the center housing, oriented with the spring pin (27). Torque the screws (29) to 8 N•m (5.9 ft-lb).
9. Lubricate the diaphragm shaft (17), then slide it into the center housing (5), guiding the air valve tube (24) through the hole in the piston. Install the two clips (46) on the shaft.
10. Liberally grease the inside of the cylinder (7) and the piston o-ring (23). Install the cylinder, making sure it is seated on the inner cover (6).
11. Install the o-ring (22) on the cylinder outer cover (11). Install the outer cover. Torque the screws (30) to 15 N•m (11 ft-lb).

12. Install the cup (47†) in the center housing.
13. Install the o-rings (43†, 44†, and 80†) on the air valve seat (33†). Lubricate the o-rings. Install the seat in the center housing (5), oriented with the spring pin (34).
14. Install the gasket (35†), cover (36), and screws and washers (38, 37). Torque to 6 N•m (4.4 ft-lb).
15. Reinstall the diaphragms (14), page 15.
16. Install the fluid covers (1). The arrows must point up. Torque the screws (31) to 27 N•m (20 ft-lb).
17. Check that the felt strips (71) are in place on the inside of the top (67) and bottom (66) covers. Install the covers. The hole for the air inlet fitting must align with the port in the center housing (5). Tighten the screws (68).
18. Install the air inlet fitting (40).

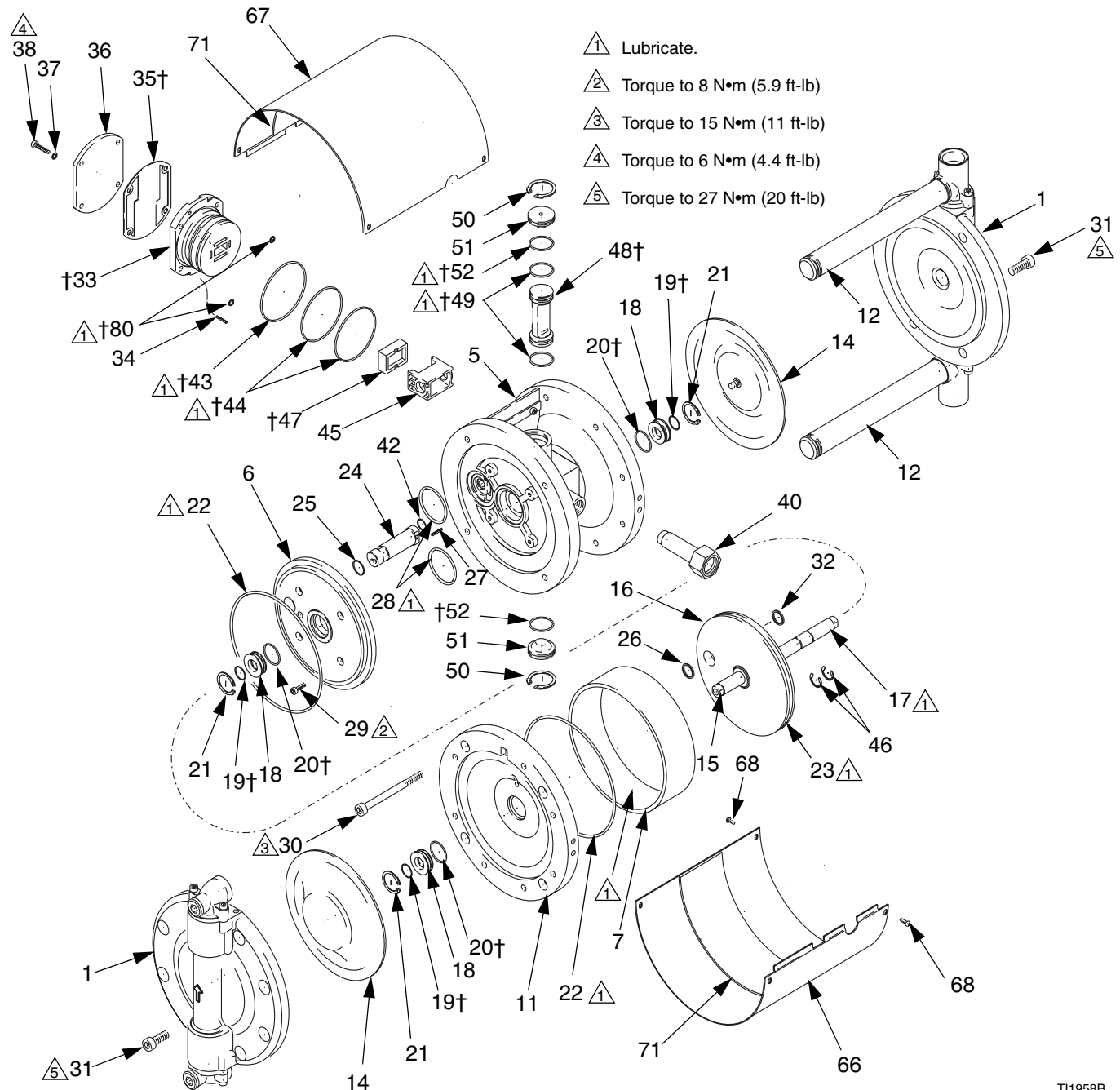

FIG. 7. Repair the Air Valve

Replace the Ball Check Valves



Ball Check Valve Repair Kit 243154 is available. Parts included in the kit are marked, for example (56‡). For the best results, use all parts in the kit.



Sealing Ring Repair Kit 243156 is available. Parts included in the kit are marked, for example (55★). For the best results, use all parts in the kit.

Disassembly

1. Prepare the pump for repair, page 14.
2. Remove the screws (38) and take the tube assemblies off the pump. See FIG. 8.
3. Remove the springs (65), ball guides (57), and balls (56) from the outlet (top) check valves.



If the ball is stuck in the seat, pry it loose with a screwdriver.



Some parts will be reused, so be careful not to drop or lose parts.

4. Insert a dowel through the outlet seats (53) and push the inlet (bottom) valve parts (65, 57, 56, 53, 58) out of the pump. Remove the flat seal (59).
5. Insert a dowel through the inlet ports and push the outlet valve seats (53) and sleeves (54) out of the pump. Remove the flat seals (55, 59).

Reassembly

CAUTION

The outlet ball check valves must be installed exactly as shown in FIG. 8:

- beveled side of seat (53) must face the ball (56)
- beveled end of sleeve (54) must face the seat (53)
- open end of ball guide (57) must face the ball (56)
- turned down end of spring (65) must face the ball guide (57)

1. Install the outlet check valves into the fluid covers (1): a flat seal (59★), seat (53‡), seal (59★), sleeve (54), ball (56‡), ball guide (57‡), spring (65‡), and seal (55★).

2. Install the outlet tube assembly. Torque the screws (38) to 10 N•m (7.4 ft-lb).

CAUTION

The inlet ball check valves must be installed exactly as shown in FIG. 8:

- turned down end of spring (65) must face the ball guide (57)
 - open end of ball guide (57) must face the ball (56)
 - beveled side of seat (53) must face the ball (56)
 - wide end of seal (58) must face the seat (53)
3. Install the inlet check valves into the fluid covers (1): a spring (65‡), ball guide (57‡), ball (56‡), seat (53‡), flat seal (59★), and seal (58).
 4. Install the inlet tube assembly. Torque the screws (38) to 10 N•m (7.4 ft-lb).

 Torque to 10 N•m (7.4 ft-lb)

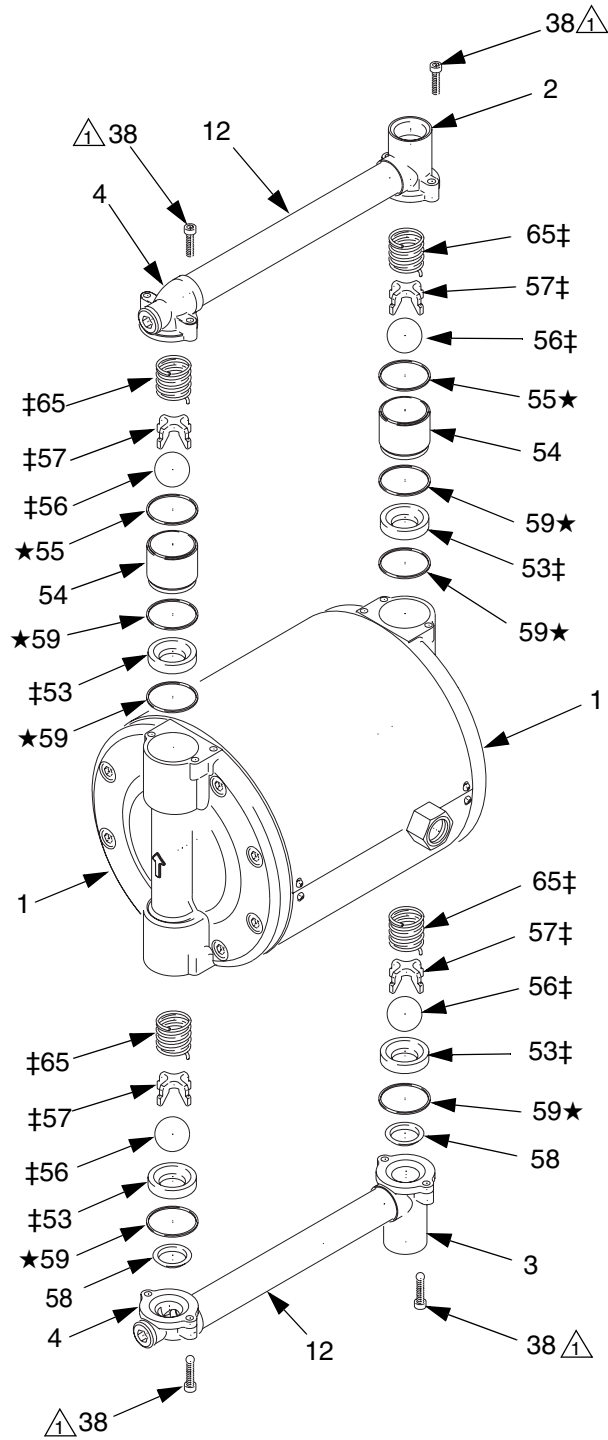

FIG. 8. Replace the Ball Check Valves

T11960A

Replace the Cylinder and Piston Seals



Cylinder Seal Repair Kit 243155 is available. Parts included in the kit are marked, for example (22♦). For the best results, use all parts in the kit.

Disassembly

1. Prepare the pump for repair, page 14.
 2. Remove the screws (38) and tube assemblies. See FIG. 9.
 3. Disassemble the ball check valves, page 19. The flat seals (55, 59) are included with this repair kit.
 4. Remove the air inlet fitting (40).
 5. Remove the screws (68) and the top (67) and bottom (66) covers.
 6. Remove the screws (31) and fluid covers (1).
 7. Remove the diaphragms (14), page 15.
 8. Remove the four screws (38) and washers (37), the air valve cover (36), and the gasket (35).
 9. Pry the air valve seat (33) out of the center housing (5), using two screwdrivers inserted in the recesses on the seat.
 10. Remove the o-rings (80) from the housing.
 11. Remove the cup (47) from the housing.
-  To further disassemble and repair the air valve, see page 17.
12. Remove the two clips (46) from the shaft (17).
 13. Remove the screws (30), cylinder outer cover (11), cylinder (7), and cylinder o-rings (22). Inspect the inner wall of the cylinder for damage.
 14. Pull the piston (16) and shaft out of the center housing (5). Remove the piston o-ring (23), quad ring (32), and packing (26). Inspect the piston and shaft for damage. If these parts need replacement, unscrew the piston shaft (15) from the diaphragm shaft (17) and remove the piston (16).

15. Remove the screws (29) and cylinder inner cover (6). Remove the air valve tube (24) and o-ring (25) from the inner cover. Do not lose the o-ring (25).
16. Remove the o-rings (28, 42) from the center housing (5). Do not lose the o-ring (28).

Reassembly



Lubricate all o-rings during reassembly.

1. Install the o-rings (42♦, 28) in the housing (5).
2. Install the o-rings (22♦, 25) on the inner cover (6).
3. Install the o-ring (23♦), packing (26♦), and quad ring (32♦) on the piston (16).
4. Insert the air valve tube (24) through the inner cover (6). Install the cover on the housing (5). Seat the tube securely in the housing, oriented with the spring pin (27). Torque the screws (29) to 8 N•m (5.9 ft-lb).
5. If the piston (16) was removed from the piston shaft (15), reassemble a washer (61), the piston, and another washer on the shaft. Screw the diaphragm shaft (17) onto the piston shaft.
6. Lubricate the shaft (17) and slide it into the housing (5), guiding the tube (24) through the hole in the piston. Install the two clips (46) on the shaft.
7. Liberally grease the inside of the cylinder (7) and the piston o-ring (23♦). Seat the cylinder securely on the inner cover (6).
8. Install the o-ring (22♦) on the outer cover (11). Install the outer cover and torque the screws (30) to 15 N•m (11 ft-lb).
9. Install the cup (47) in the center housing (5).
10. Install the o-rings (80). Check that the o-rings (43, 44) are in place on the air valve seat (33). Lubricate the o-rings. Install the seat in the center housing (5), oriented with the spring pin (34).
11. Install the gasket (35), cover (36), and screws and washers (38, 37). Torque to 6 N•m (4.4 ft-lb).

12. Install the diaphragms (14), page 15.
13. Install the fluid covers (1). The arrows must point up. Torque the screws (31) to 27 N•m (20 ft-lb).
14. Check that the felt strips (71) are in place on the inside of the top (67) and bottom (66) covers. Install the covers. The hole for the air inlet fitting must align with the port in the center housing (5). Tighten the screws (68).
15. Install the air inlet fitting (40).
16. Install the flat seals (55♦, 59♦) and the other ball check parts, see page 19.
17. Install the tube assemblies. Torque the screws (38) to 10 N•m (7.4 ft-lb).

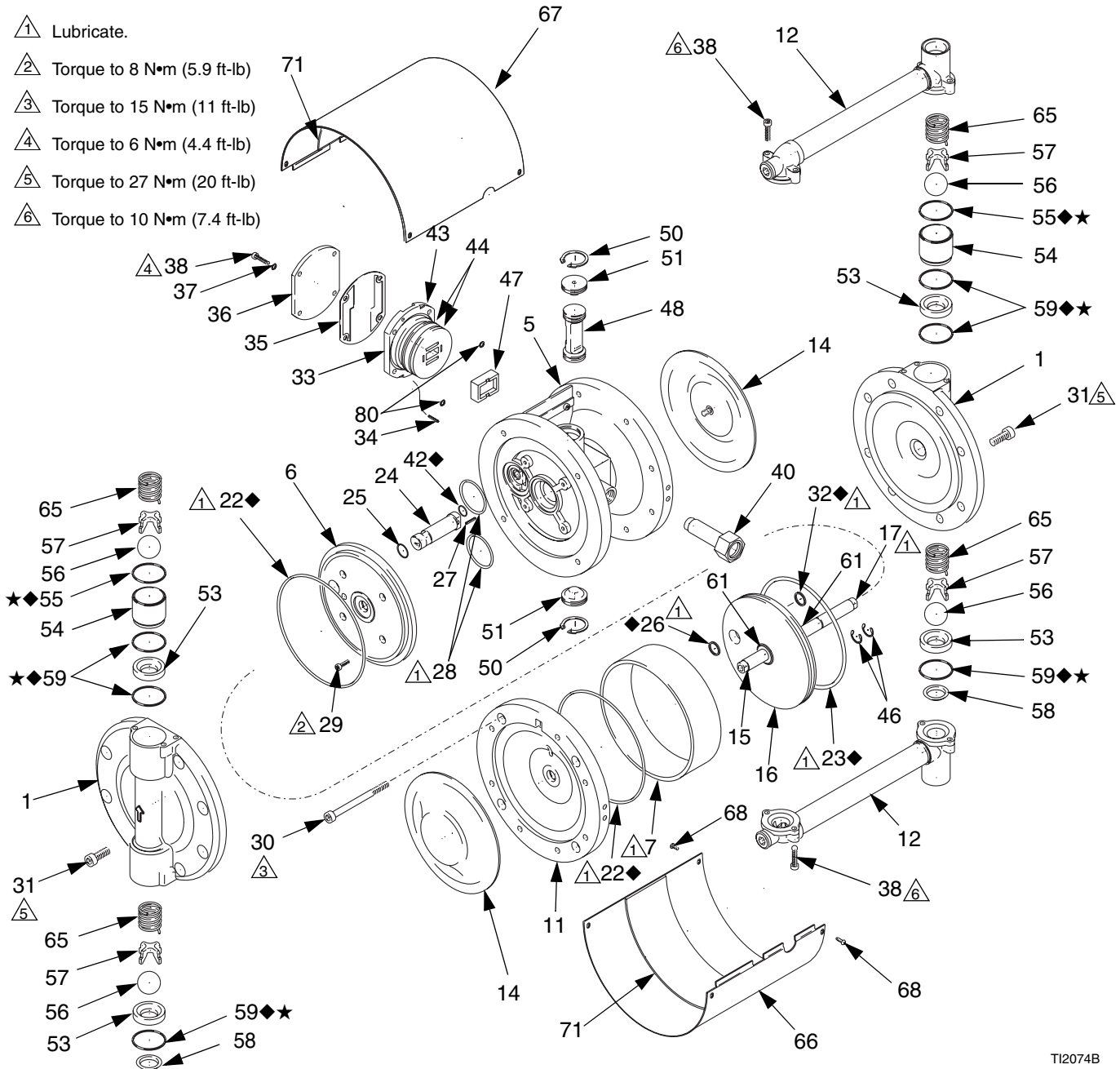

FIG. 9. Replace the Cylinder and Piston Seals

T12074B

Parts

Part No. 253707 includes items 1-81

Part No. 253708 includes items 1-8,10-59, 61-81

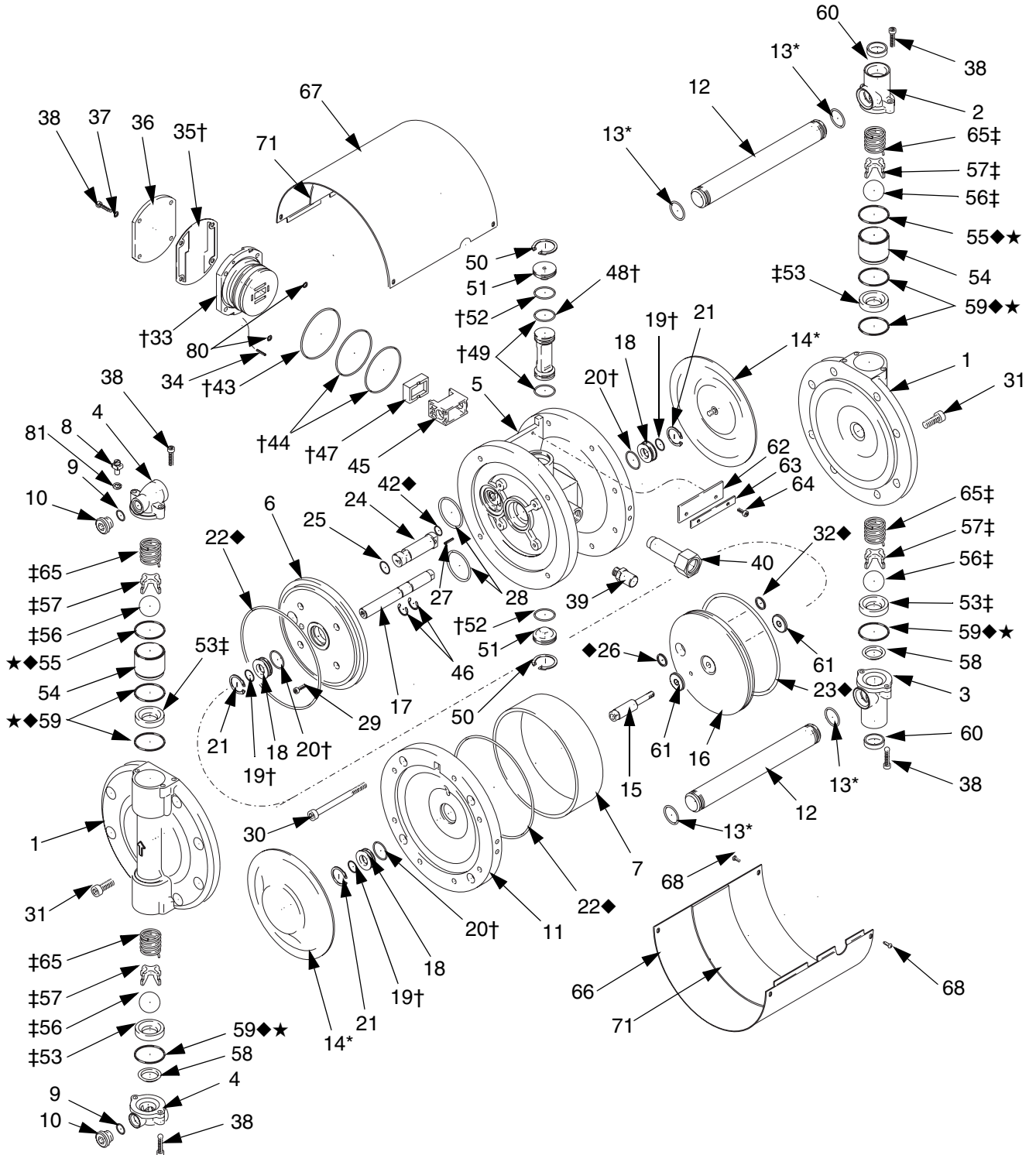

T11957B

Part No. 253707 includes items 1-81

Part No. 253708 includes items 1-8,10-59, 61-81

Ref. No.	Part No.	Description	Qty	Ref. No.	Part No.	Description	Qty
				38	117029	SCREW, cap, socket-hd; M6 x 25	12
1	15A010	COVER, fluid	2	39	117019	VALVE, safety, relief	1
2	15A000	HOUSING, outlet, fluid; for 253707	1	40	15A790	FITTING, inlet, air; for 253707	1
	15A003	HOUSING, outlet, fluid; for 253708	1		15A044	FITTING, inlet, air; for 253708	1
3	15A002	HOUSING, inlet, fluid; for 253707	1	42◆		O-RING; nitrile	1
	15A003	HOUSING, inlet, fluid; for 253708	1	43†		O-RING; nitrile	1
4	15A001	HOUSING, tube, fluid; for 253707	2	44†		O-RING; nitrile	2
	15A004	HOUSING, tube, fluid; for 253708	2	45	15A033	CARRIAGE	1
5	15A032	HOUSING, center	1	46	117022	CLIP, c-spring	2
6	15A051	COVER, inner, cylinder	1	47†		CUP, air valve	1
7	15A050	CYLINDER	1	48†		CARRIAGE, driver	1
8	116343	CLAMP, grounding	1	49†		O-RING; nitrile	2
9	116898	WASHER; for 253707 only	2	50	117020	CLIP, c-spring	2
10	116902	PLUG, socket-hd; for 253707	2	51	15A009	PLUG, air valve	2
	112306	PLUG, pipe; for 253708	2	52†		O-RING; nitrile	2
11	15A052	COVER, outer, cylinder	1	53‡		SEAT, valve	4
12	15A037	TUBE, fluid	2	54	15A026	SLEEVE, ball guide	2
13*		O-RING; chemically resistant fluoroelastomer	4	55◆★		SEAL, flat; UHMWPE	2
				56‡		BALL, 30 mm; acetal	4
14*		DIAPHRAGM; PTFE	2	57‡		GUIDE, ball	4
15	15A042	SHAFT, piston	1	58	15A036	SEAL; acetal homopolymer	2
16	15A038	PISTON	1	59◆★		SEAL, flat; UHMWPE	6
17	15A043	SHAFT, diaphragm	1	60	15A005	BUSHING; for 253707 only	2
18	15A006	BEARING	3	61	15A482	WASHER	2
19†		O-RING; fluoroelastomer	3	62	15A016	DAMPENER, noise	2
20†		O-RING; nitrile	3	63	15A028	PLATE	2
21	117021	CLIP, c-spring	3	64	117026	SCREW, cap, socket-hd; M5 x 12	4
22◆		O-RING; nitrile	2	65‡		SPRING, compression	4
23◆		O-RING; nitrile	1	66	15J373	COVER, bottom	1
24	15A031	TUBE, air valve	1	67	15J375	COVER, top	1
25	117006	O-RING; nitrile	1	68	116595	SCREW; M4 x 0.7	8
26◆		PACKING, PTFE	1	70▲	188621	LABEL, warning (not shown)	1
27	117023	PIN, spring	1	71	15A008	DAMPENER, felt	2
28	117012	O-RING; fluoroelastomer	2	80†	158486	O-ring, nitrile	2
29	117028	SCREW, socket-hd; M6 x 16	4	81	111307	WASHER	1
30	117034	SCREW, socket-hd; M8 x 100	4				
31	116900	SCREW, cap, socket-hd; M10 x 25	16			* Included in Diaphragm Repair Kit 243152.1	
32◆		RING, quad; nitrile	1			† Included in Air Valve Repair Kit 243153.	
33†		SEAT, air valve	1			‡ Included in Ball Check Valve Repair Kit 243154.	
34	117024	PIN, spring	1			◆ Included in Cylinder Seal Repair Kit 243155.	
35†		GASKET	1			★ Included in Sealing Ring Repair Kit 243156.	
36	15A035	COVER, air valve	1			▲ Replacement Warning labels, signs, tags, and cards are available at no cost.	
37	117018	WASHER	4				

Technical Data

Category	Data
Maximum fluid working pressure	1.8 MPa, 18 bar (260 psi)
Maximum air input pressure	0.6 MPa, 6 bar (88 psi)
Ratio	3:1
Maximum recommended flow rate (continuous duty)	7.6 liters/min (2.0 gpm)
Maximum recommended cycle rate	20 cycles/minute
Maximum flow rate	114 liters/min (30 gpm)
Volume per cycle (double stroke)	350 cc/cycle (11 oz/cycle)
Operating temperature range	10-80°C (50-176°F)
Dry suction lift	2.5 m (8.2 ft)
Wet suction lift	6.7 m (22 ft)
Air inlet size	<i>Model 253707: 1/2 BSPP(f)</i> <i>Model 253708: 1/2 npt(f)</i>
Fluid inlet size	<i>Model 253707: 1 in. BSPP(f)</i> <i>Model 253708: 1 in. npt(f)</i>
Fluid outlet size	<i>Model 253707: 1 in. BSPP(f)</i> <i>Model 253708: 1 in. npt(f)</i>
Sound power level at 15 cycles/min, 0.6 MPa, 6 bar (88 psi) air inlet pressure. Tested per ISO 9614-2.	66 dB(A)
Weight (approximate)	29 kg (64 lb)
Wetted parts	303 and 316 stainless steel, acetal, fluorocarbon, ultra-high molecular weight polyethylene, PTFE

Performance Charts

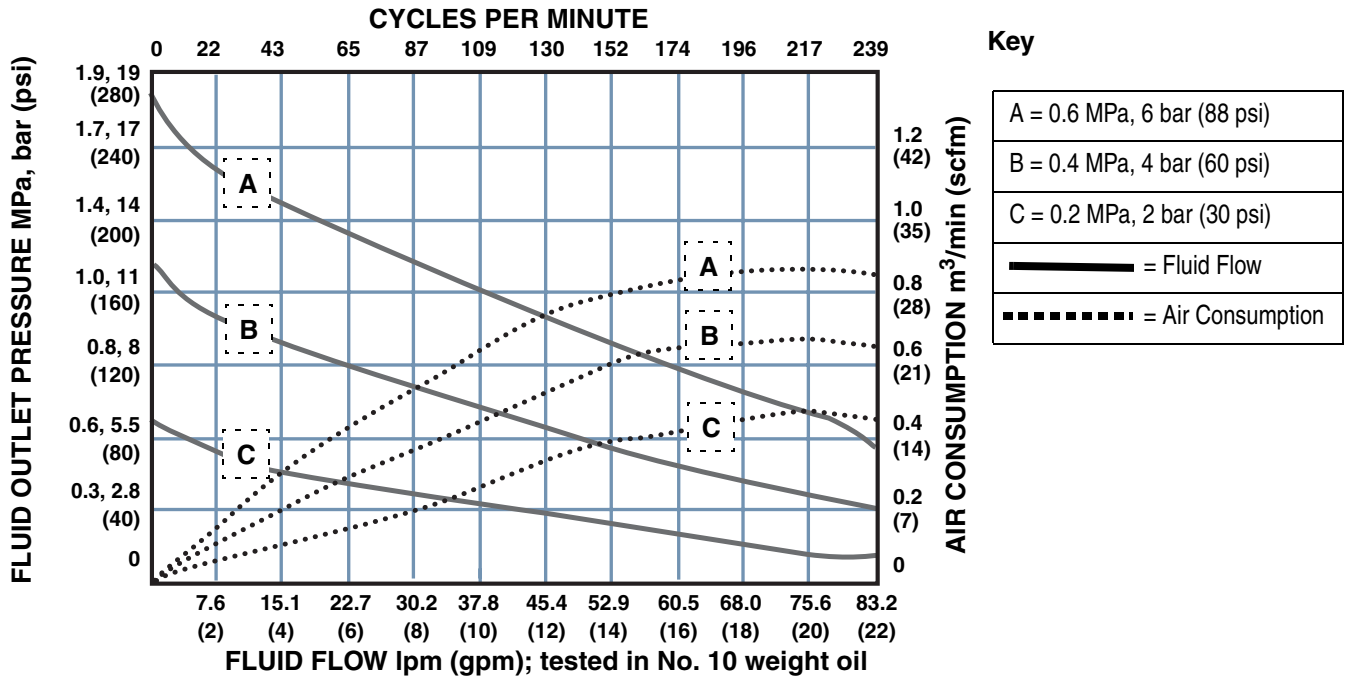

Recommended Performance for Continuous Duty

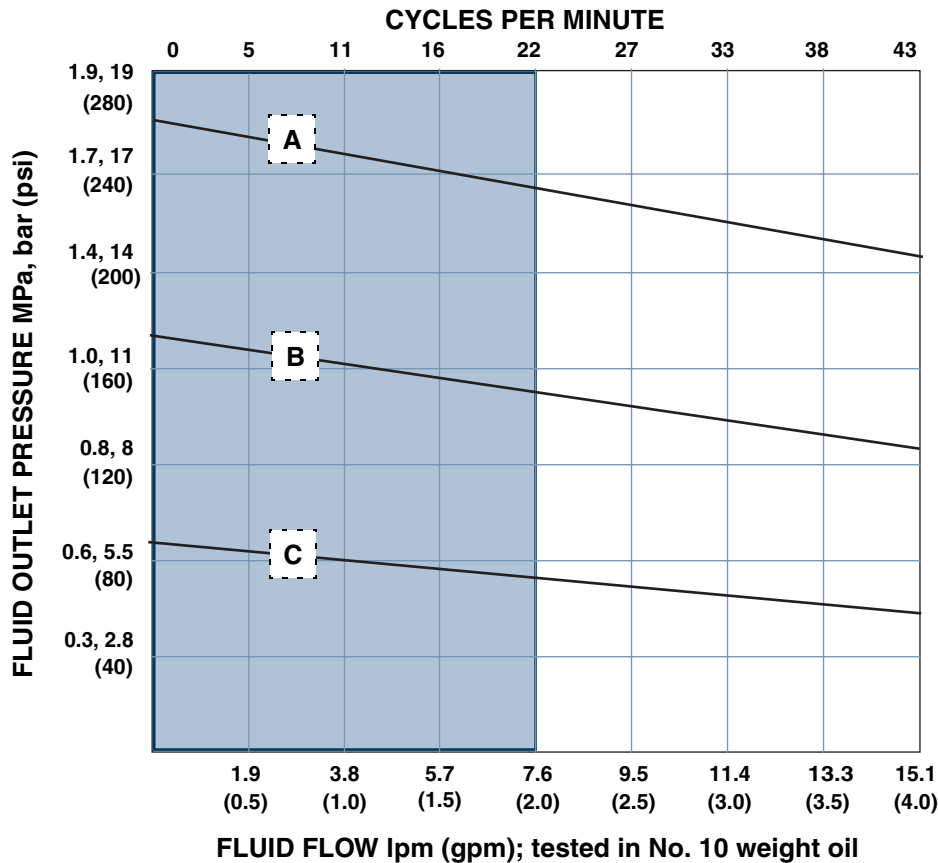

Dimensions

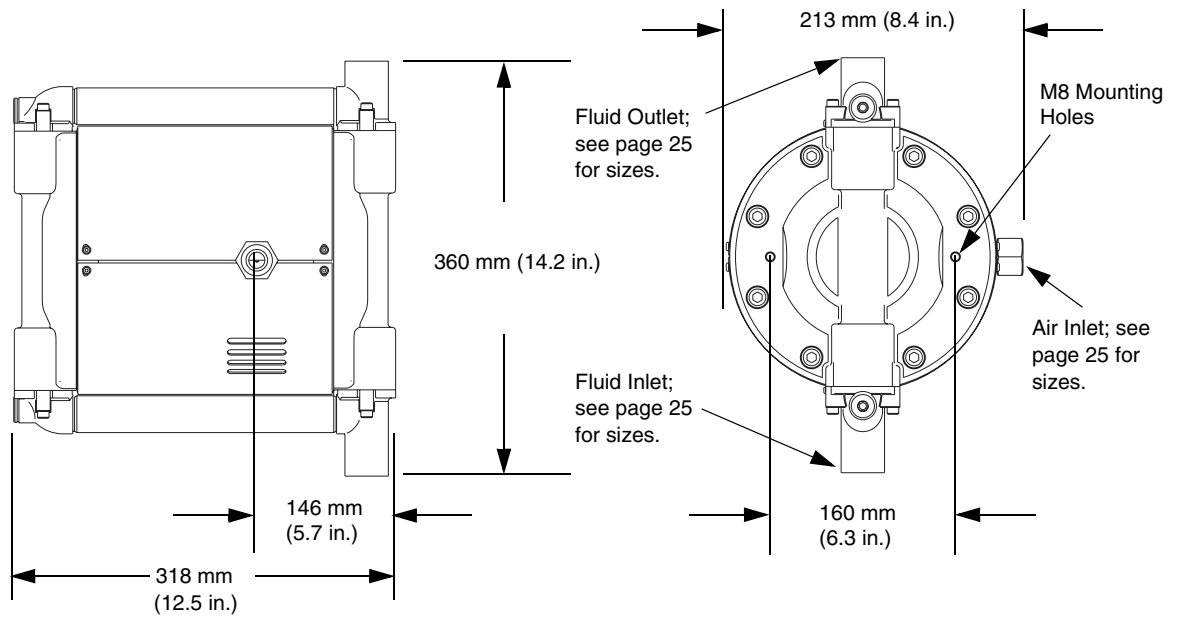

TI1964A
TI1963A

Wall Mount Hole Pattern

For Accessory Wall Mount Kit 245875

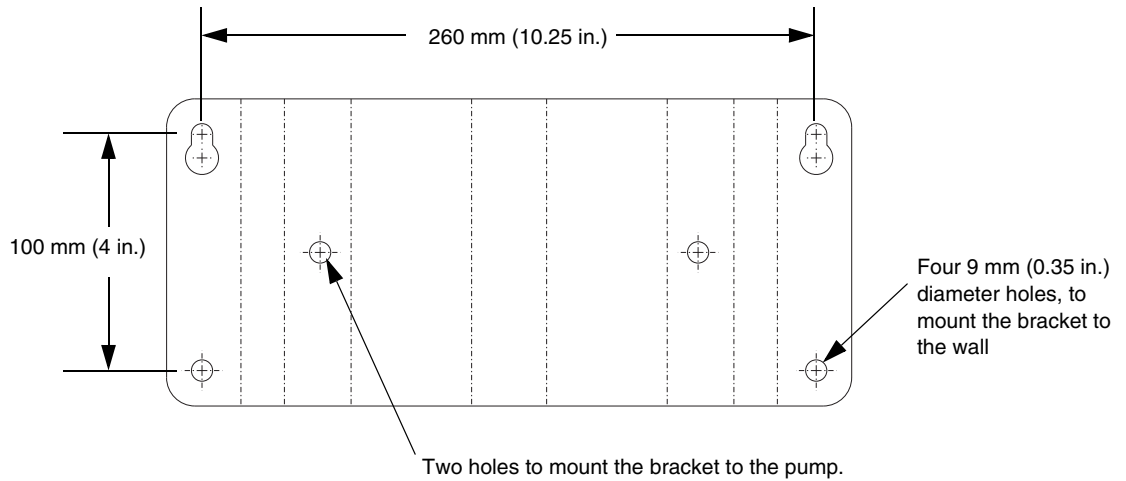

TI2118

Graco Standard Warranty

Graco warrants all equipment referenced in this document which is manufactured by Graco and bearing its name to be free from defects in material and workmanship on the date of sale to the original purchaser for use. With the exception of any special, extended, or limited warranty published by Graco, Graco will, for a period of twelve months from the date of sale, repair or replace any part of the equipment determined by Graco to be defective. This warranty applies only when the equipment is installed, operated and maintained in accordance with Graco's written recommendations.

This warranty does not cover, and Graco shall not be liable for general wear and tear, or any malfunction, damage or wear caused by faulty installation, misapplication, abrasion, corrosion, inadequate or improper maintenance, negligence, accident, tampering, or substitution of non-Graco component parts. Nor shall Graco be liable for malfunction, damage or wear caused by the incompatibility of Graco equipment with structures, accessories, equipment or materials not supplied by Graco, or the improper design, manufacture, installation, operation or maintenance of structures, accessories, equipment or materials not supplied by Graco.

This warranty is conditioned upon the prepaid return of the equipment claimed to be defective to an authorized Graco distributor for verification of the claimed defect. If the claimed defect is verified, Graco will repair or replace free of charge any defective parts. The equipment will be returned to the original purchaser transportation prepaid. If inspection of the equipment does not disclose any defect in material or workmanship, repairs will be made at a reasonable charge, which charges may include the costs of parts, labor, and transportation.

THIS WARRANTY IS EXCLUSIVE, AND IS IN LIEU OF ANY OTHER WARRANTIES, EXPRESS OR IMPLIED, INCLUDING BUT NOT LIMITED TO WARRANTY OF MERCHANTABILITY OR WARRANTY OF FITNESS FOR A PARTICULAR PURPOSE.

Graco's sole obligation and buyer's sole remedy for any breach of warranty shall be as set forth above. The buyer agrees that no other remedy (including, but not limited to, incidental or consequential damages for lost profits, lost sales, injury to person or property, or any other incidental or consequential loss) shall be available. Any action for breach of warranty must be brought within two (2) years of the date of sale.

GRACO MAKES NO WARRANTY, AND DISCLAIMS ALL IMPLIED WARRANTIES OF MERCHANTABILITY AND FITNESS FOR A PARTICULAR PURPOSE, IN CONNECTION WITH ACCESSORIES, EQUIPMENT, MATERIALS OR COMPONENTS SOLD BUT NOT MANUFACTURED BY GRACO. These items sold, but not manufactured by Graco (such as electric motors, switches, hose, etc.), are subject to the warranty, if any, of their manufacturer. Graco will provide purchaser with reasonable assistance in making any claim for breach of these warranties.

In no event will Graco be liable for indirect, incidental, special or consequential damages resulting from Graco supplying equipment hereunder, or the furnishing, performance, or use of any products or other goods sold hereto, whether due to a breach of contract, breach of warranty, the negligence of Graco, or otherwise.

FOR GRACO CANADA CUSTOMERS

The Parties acknowledge that they have required that the present document, as well as all documents, notices and legal proceedings entered into, given or instituted pursuant hereto or relating directly or indirectly hereto, be drawn up in English. Les parties reconnaissent avoir convenu que la rédaction du présente document sera en Anglais, ainsi que tous documents, avis et procédures judiciaires exécutés, donnés ou intentés, à la suite de ou en rapport, directement ou indirectement, avec les procédures concernées.

Graco Information

TO PLACE AN ORDER, contact your Graco distributor, or call this number to identify the distributor closest to you:

1-800-328-0211 Toll Free

612-623-6921

612-378-3505 Fax

*All written and visual data contained in this document reflects the latest product information available at the time of publication.
Graco reserves the right to make changes at any time without notice.*

This manual contains English. MM 311689

Graco Headquarters: Minneapolis

International Offices: Belgium, China, Japan, Korea

GRACO INC. P.O. BOX 1441 MINNEAPOLIS, MN 55440-1441

Copyright 2006, Graco Inc. is registered to I.S. EN ISO 9001

www.graco.com

Revised 6/2008