

Merkur[®] Pump Assembly

312794D

For high-performance finishing and coating applications in hazardous or non-hazardous locations.



Important Safety Instructions

Read all warnings and instructions in this manual.
Save these instructions.

See page 4 for model information, including maximum working pressure.



T112811a

Contents

Pump Part Number Matrix	3	Maintenance	13
Pump Models	4	Preventive Maintenance Schedule	13
Warnings	5	Tighten Threaded Connections	13
Related Manuals	6	Flush the Pump	13
Component Identification	7	Wet Cup	13
Installation	8	Troubleshooting	14
General Information	8	Repair	15
Prepare the Operator	8	General Information	15
Prepare the Site	8	Disconnect the Displacement Pump	15
Grounding	8	Reconnect the Displacement Pump	16
Mount the Pump	9	Disconnect the Air Motor	17
Air and Fluid Hoses	9	Reconnect the Air Motor	17
Accessories	9	Pump Parts	18
Typical Installation	10	Parts That Vary by Model	19
Operation	11	Repair Kits	20
Pressure Relief Procedure	11	Performance Charts	21
Flush Before Using Equipment	11	Pump Dimensions	28
Trigger Lock	11	Wall Bracket Mounting Dimensions	29
Wet Cup	11	Technical Data	29
Prime and Adjust the Pump	12	Graco Standard Warranty	30
Shutdown and Care of the Pump	12	Graco Information	30

Pump Part Number Matrix

Check your pump's identification plate (ID) for the 6-digit part number. Use the following matrix to define the construction of your pump, based on the six digits. For example, Part No. **W 1 5 A A S** represents a wet cup pump (**W**), 15 to 1 ratio (**15**), 25 cc lower (**A**), 3 UHMWPE/2 PTFE packings with chromex rod coating, no data monitoring, low noise exhaust (**A**), and stainless steel construction (**S**).

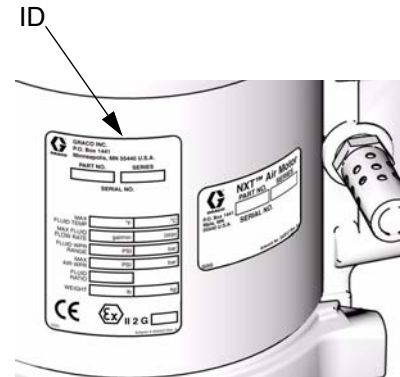

ti12922a

W	15	A		A		S
First Digit (Wet cup)	Second and Third Digits (pressure ratio - XX:1)	Fourth Digit (Displacement pump volume per cycle*)		Fifth Digit (Packings - X UHMWPE:X PTFE/ Piston Rod Coating/ Data Monitoring/Exhaust)		Sixth Digit (lower material)
W	10	A	25 cc	A	3:2/Chromex/No Monitoring/Low Noise	S Stainless steel
	15	B	50 cc	B	3:2/Chromex/DataTrak™/Low Noise	
	18	C	75 cc	E	3:2/Chromex/DataTrak™ Cycle Count Only/Low Noise	
	23	D	100 cc			
	24	E	125 cc			
	28	F	150 cc			
	30					
	36					
	45					
	48					





* Cycle refers to combination of one upstroke and one downstroke.





Pump Models

Model, Series	Air Motor	Displacement Pump	Maximum Fluid Working Pressure psi (MPa, bar)	Flow Rate at 60 cpm gpm (lpm)	Fluid Inlet	Fluid Outlet	Air Inlet
W10CAS, Series A	M04LN0	LW075A	1000 (6.9, 69)	1.2 (4.5)	3/4 in. npt	3/8 in. npt	1/4 npt(f)
W10CBS, Series A	M04LTO						
W15AAS, Series A	M02LN0	LW025A	1500 (10.3, 103)	0.4 (1.5)	1/2 in. npt	3/8 in. npt	1/4 npt(f)
W15BAS, Series A	M04LN0	LW050A	1500 (10.3, 103)	0.8 (3.0)	3/4 in. npt	3/8 in. npt	1/4 npt(f)
W15BBS, Series A	M04LTO						
W15FAS, Series A	M12LN0	LW150A	1500 (10.3, 103)	2.4 (9.0)	1 in. npt	3/4 in. npt	1/2 npt(f)
W15FBS, Series A	M12LTO						
W18EAS, Series A	M12LN0	LW125A	1800 (12.4, 124)	2.0 (7.5)	1 in. npt	1/2 in. npt	1/2 npt(f)
W18EBS, Series A	M12LTO						
W23DAS, Series A	M12LN0	LW100A	2300 (15.8, 158)	1.6 (6.0)	3/4 in. npt	3/8 in. npt	1/2 npt(f)
W23DBS, Series A	M12LTO						
W24FAS, Series A	M18LN0	LW150A	2400 (16.5, 165)	2.4 (9.0)	1 in. npt	3/4 in. npt	1/2 npt(f)
W24FBS, Series A	M18LTO						
W28EAS, Series A	M18LN0	LW125A	2800 (19.3, 193)	2.0 (7.5)	1 in. npt	1/2 in. npt	1/2 npt(f)
W28EBS, Series A	M18LTO						
W30AAS, Series A	M04LN0	LW025A	3000 (20.7, 207)	0.4 (1.5)	1/2 in. npt	3/8 in. npt	1/4 npt(f)
W30ABS, Series A	M04LTO						
W30CAS, Series A	M12LN0	LW075A	3000 (20.7, 207)	1.2 (4.5)	3/4 in. npt	3/8 in. npt	1/2 npt(f)
W30CBS, Series A	M12LTO						
W36DAS, Series A	M18LN0	LW100A	3600 (24.8, 248)	1.6 (6.0)	3/4 in. npt	3/8 in. npt	1/2 npt(f)
W36DBS, Series A	M18LTO						
W45BAS, Series A	M12LN0	LW050A	4500 (31.0, 310)	0.8 (3.0)	3/4 in. npt	3/8 in. npt	1/2 npt(f)
W45BBS, Series A	M12LTO						
W48CAS, Series A	M18LN0	LW075A	4800 (33.1, 331)	1.2 (4.5)	3/4 in. npt	3/8 in. npt	1/2 npt(f)
W48CBS, Series A	M18LTO						

Warnings

The following warnings are for the setup, use, grounding, maintenance, and repair of this equipment. The exclamation point symbol alerts you to a general warning and the hazard symbol refers to procedure-specific risk. Refer back to these warnings. Additional, product-specific warnings may be found throughout the body of this manual where applicable.

 WARNING	
	<p>FIRE AND EXPLOSION HAZARD</p> <p>Flammable fumes, such as solvent and paint fumes, in work area can ignite or explode. To help prevent fire and explosion:</p> <ul style="list-style-type: none"> • Use equipment only in well ventilated area. • Eliminate all ignition sources; such as pilot lights, cigarettes, portable electric lamps, and plastic drop cloths (potential static arc). • Keep work area free of debris, including solvent, rags and gasoline. • Do not plug or unplug power cords, or turn power or light switches on or off when flammable fumes are present. • Ground all equipment in the work area. See Grounding instructions. • Use only grounded hoses. • Hold gun firmly to side of grounded pail when triggering into pail. • If there is static sparking or you feel a shock, stop operation immediately. Do not use equipment until you identify and correct the problem. • Keep a working fire extinguisher in the work area.
	<p>EQUIPMENT MISUSE HAZARD</p> <p>Misuse can cause death or serious injury.</p> <ul style="list-style-type: none"> • Do not operate the unit when fatigued or under the influence of drugs or alcohol. • Do not exceed the maximum working pressure or temperature rating of the lowest rated system component. See Technical Data in all equipment manuals. • Use fluids and solvents that are compatible with equipment wetted parts. See Technical Data in all equipment manuals. Read fluid and solvent manufacturer's warnings. For complete information about your material, request MSDS forms from distributor or retailer. • Check equipment daily. Repair or replace worn or damaged parts immediately with genuine manufacturer's replacement parts only. • Do not alter or modify equipment. • Use equipment only for its intended purpose. Call your distributor for information. • Route hoses and cables away from traffic areas, sharp edges, moving parts, and hot surfaces. • Do not kink or over bend hoses or use hoses to pull equipment. • Keep children and animals away from work area. • Comply with all applicable safety regulations.
	<p>SKIN INJECTION HAZARD</p> <p>High-pressure fluid from gun, hose leaks, or ruptured components will pierce skin. This may look like just a cut, but it is a serious injury that can result in amputation. Get immediate surgical treatment.</p> <ul style="list-style-type: none"> • Do not point gun at anyone or at any part of the body. • Do not put your hand over the spray tip. • Do not stop or deflect leaks with your hand, body, glove, or rag. • Do not spray without tip guard and trigger guard installed. • Engage trigger lock when not spraying. • Follow Pressure Relief Procedure in this manual, when you stop spraying and before cleaning, checking, or servicing equipment.

 WARNING	
	<p>PRESSURIZED EQUIPMENT HAZARD</p> <p>Fluid from the gun/dispense valve, leaks, or ruptured components can splash in the eyes or on skin and cause serious injury.</p> <ul style="list-style-type: none"> • Follow Pressure Relief Procedure in this manual, when you stop spraying and before cleaning, checking, or servicing equipment. • Tighten all fluid connections before operating the equipment. • Check hoses, tubes, and couplings daily. Replace worn or damaged parts immediately.
	<p>MOVING PARTS HAZARD</p> <p>Moving parts can pinch or amputate fingers and other body parts.</p> <ul style="list-style-type: none"> • Keep clear of moving parts. • Do not operate equipment with protective guards or covers removed. • Pressurized equipment can start without warning. Before checking, moving, or servicing equipment, follow the Pressure Relief Procedure in this manual. Disconnect power or air supply.
	<p>TOXIC FLUID OR FUMES HAZARD</p> <p>Toxic fluids or fumes can cause serious injury or death if splashed in the eyes or on skin, inhaled, or swallowed.</p> <ul style="list-style-type: none"> • Read MSDS's to know the specific hazards of the fluids you are using. • Store hazardous fluid in approved containers, and dispose of it according to applicable guidelines. • Always wear impervious gloves when spraying or cleaning equipment.
	<p>PERSONAL PROTECTIVE EQUIPMENT</p> <p>You must wear appropriate protective equipment when operating, servicing, or when in the operating area of the equipment to help protect you from serious injury, including eye injury, inhalation of toxic fumes, burns, and hearing loss. This equipment includes but is not limited to:</p> <ul style="list-style-type: none"> • Protective eyewear • Clothing and respirator as recommended by the fluid and solvent manufacturer • Gloves • Hearing protection

Related Manuals

Manual	Description
312792	Merkur Displacement Pump
312796	NXT™ Air Motor
312797	Merkur Non-Heated Spray Packages
312798	Merkur Electrostatic Spray Packages, Ambient and Heated
313255	Merkur Heated Spray Packages

Component Identification

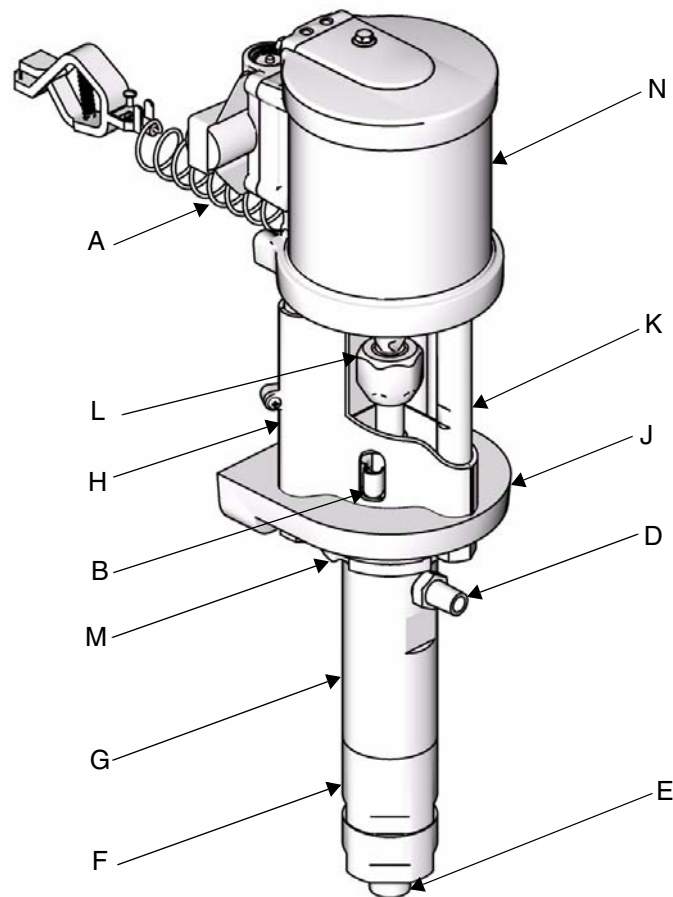

ti11700a

FIG. 1. Component Identification

Key:

- A Ground Wire
- B TSL Reservoir
- C Wet Cup (not visible, under TSL reservoir)
- D Fluid Outlet
- E Fluid Inlet
- F Lower Cylinder
- G Upper Cylinder
- H Tie Rod Shield
- J Displacement Pump Adapter
- K Tie Rod
- L Coupling Nut
- M Jam Nut
- N Air Motor

Installation

General Information

 Reference numbers and letters in parentheses in the text refer to the callouts in the figures and the parts drawing.

 Always use Genuine Graco Parts and Accessories, available from your Graco distributor. If you supply your own accessories, be sure they are adequately sized and pressure-rated for your system.

Prepare the Operator

All persons who operate the equipment must be trained in the operation of all system components as well as the proper handling of all fluids. All operators must thoroughly read all instruction manuals, tags, and labels before operating the equipment.

Prepare the Site

Ensure that you have an adequate compressed air supply.

Bring a compressed air supply line from the air compressor to the pump location. Be sure all air hoses are properly sized and pressure-rated for your system. Use only electrically conductive hoses.

Keep the site clear of any obstacles or debris that could interfere with the operator's movement.

Have a grounded, metal pail available for use when flushing the system.

Grounding

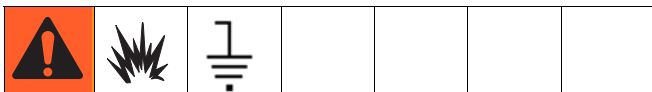

The equipment must be grounded. Grounding reduces the risk of static and electric shock by providing an escape wire for the electrical current due to static build up or in the event of a short circuit.

Pump: See FIG. 2. Verify that the ground screw (GS) is attached and tightened securely to the air motor. Connect the other end of the ground wire (U) to a true earth ground.

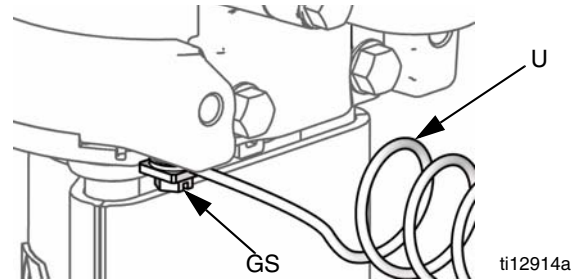

FIG. 2. Ground screw and wire

Air and fluid hoses: Static electricity may build up when fluids flow through pumps, hoses, and sprayers. At least one hose must be electrically conductive, with a maximum of 500 ft. (150 m) combined hose length to ensure grounding continuity. Check electrical resistance of hose. If total resistance to ground exceeds 25 megohms, replace hose immediately.

Air compressor: follow manufacturer's recommendations.

Spray gun / Dispense valve: Ground the spray gun through connection to a Graco-approved grounded fluid hose.

Fluid supply container: follow local code.

Object being sprayed: follow local code.

Solvent pails used when flushing: follow local code. Use only conductive metal pails, placed on a grounded surface. Do not place the pail on a nonconductive surface, such as paper or cardboard, which interrupts grounding continuity.

To maintain grounding continuity when flushing or relieving pressure: hold metal part of the spray gun/dispense valve firmly to the side of a grounded metal pail, then trigger the gun/valve.

Mount the Pump

Mount the pump only to Graco wall bracket 15T795, or to a Graco cart, available from your distributor. Pump dimensions are shown on page 28. For wall mounted pumps, follow these guidelines:

1. Be sure the wall can support the weight of the pump, bracket, hoses and accessories, as well as the stress caused during operation.
2. Position the wall bracket about 1.2-1.5 m (4-5 ft) above the floor. For ease of operation and service, make sure the pump air inlet, fluid inlet, and fluid outlet ports are easily accessible.
3. Using the wall bracket as a template, drill 10 mm (0.4 in.) mounting holes in the wall. Wall mounting dimensions are shown on page 29.
4. Attach the bracket to the wall. Use 9 mm (3/8 in.) screws that are long enough to keep the pump from vibrating during operation.

NOTE: Be sure the bracket is level.

Air and Fluid Hoses



Be sure all air hoses (N) and fluid hoses (M) are properly sized and pressure rated for your system. See FIG. 3. Use only electrically conductive fluid hoses.

Accessories

Install the following accessories in the order shown in FIG. 3, using adapters as necessary.

Air Line

- **Bleed-type master air valve (E):** required in your system to relieve air trapped between it and the air motor and gun when the valve is closed.

						
Trapped air can cause the pump to cycle unexpectedly, which could result in serious injury from splashing or moving parts.						

Be sure the valve is easily accessible from the pump and located downstream from the air regulator.

- **Pump air regulator (H):** controls pump speed and outlet pressure. Locate it close to the pump.
- **Air line filter (B):** removes harmful dirt and moisture from compressed air supply.
- **Air shutoff valve (A):** isolates air line accessories for servicing. Locate upstream from all other air line accessories.
- **Gun air regulator (D):** controls air pressure to the air-assisted spray gun.

Fluid Line

- **Fluid filter (P):** with a 60 mesh (250 micron) stainless steel element to filter particles from the fluid as it leaves the pump.
- **Fluid drain valve (W):** required in your system, to relieve fluid pressure in the hose and gun.
- **Gun or valve (L):** dispenses the fluid. The gun shown in FIG. 3 is an air-assisted spray gun for light to medium viscosity fluids.
- **Fluid line swivel (K):** for easier gun movement.
- **Suction kit (V):** enables the pump to draw fluid from a container.

Typical Installation

- | | | | |
|---|--|---|--|
| A | Air Shutoff Valve | L | Air-Assisted Spray Gun |
| B | Air Filter (optional accessory) | M | Gun Fluid Supply Hose |
| C | Gun Air Pressure Gauge | N | Gun Air Supply Hose |
| D | Gun Air Pressure Regulator | P | Fluid Filter |
| E | Bleed Type Master Air Valve | R | Pump Fluid Outlet |
| F | DataTrak | S | Grounding Wire |
| G | Pump Air Pressure Gauge | T | Wet-Cup (not visible, see FIG. 4, page 11) |
| H | Pump Air Pressure Regulator | U | Pump Fluid Inlet |
| J | Solenoid Release Button
(not visible) | V | Suction Hose |
| K | Gun Swivel | W | Fluid Drain Valve |

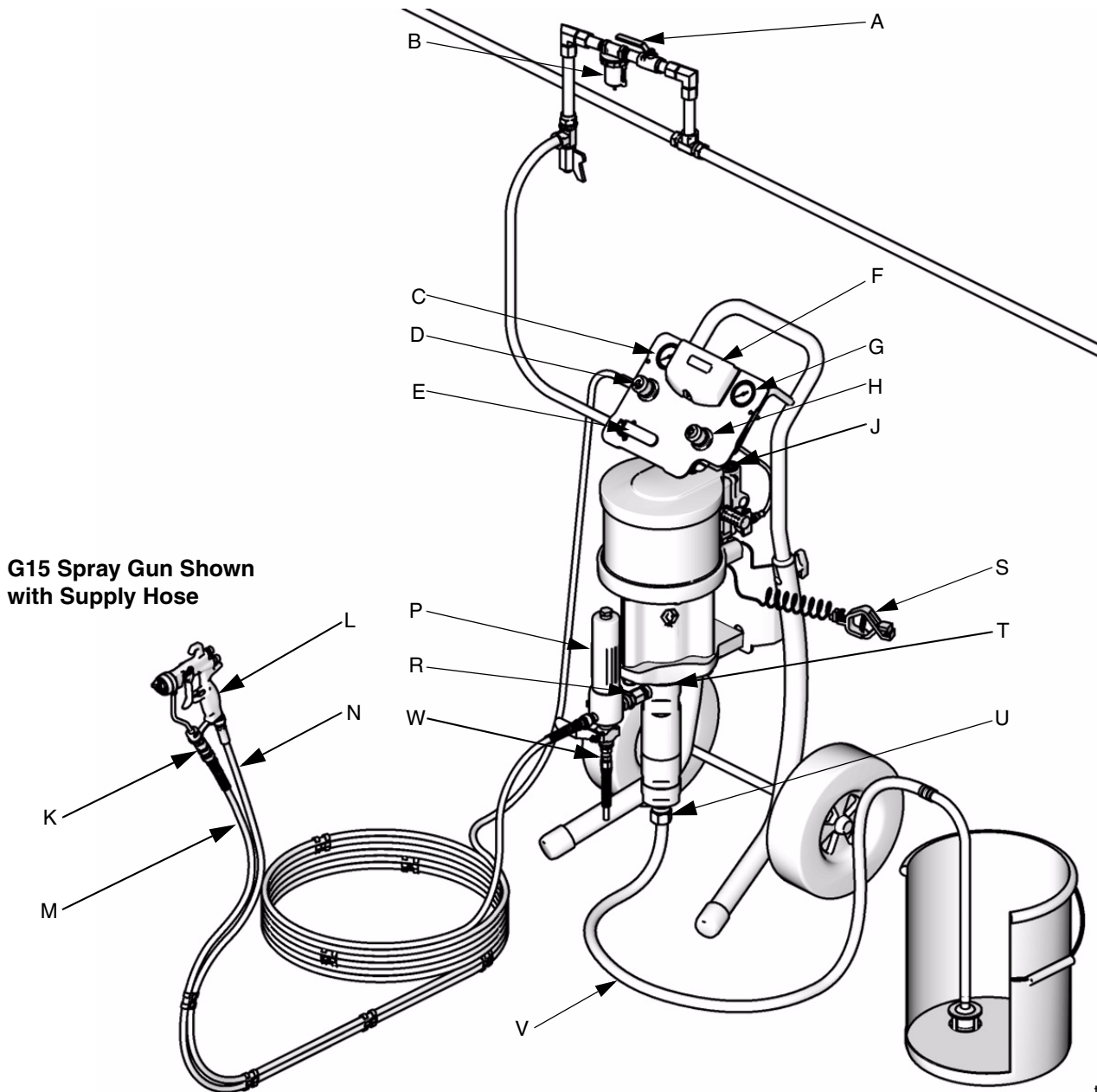



ti12800a

FIG. 3. Typical Installation. (Graco Cart-Mounted Package Shown.)

Operation

Pressure Relief Procedure

						
<p>Trapped air can cause the pump to cycle unexpectedly, which could result in serious injury from splashing or moving parts.</p>						

1. Engage the trigger lock.
2. Close the bleed-type master air valve.
3. Disengage the trigger lock.
4. Hold a metal part of the gun firmly to a grounded metal pail. Trigger the gun to relieve pressure.
5. Engage the trigger lock.
6. Open all fluid drain valves in the system, having a waste container ready to catch drainage. Leave drain valve(s) open until you are ready to spray again.
7. If you suspect the spray tip or hose is clogged or that pressure has not been fully relieved after following the steps above, **VERY SLOWLY** loosen tip guard retaining nut or hose end coupling to relieve pressure gradually, then loosen completely. Clear hose or tip obstruction.



Flush Before Using Equipment

The equipment was tested with lightweight oil, which is left in the fluid passages to protect parts. To avoid contaminating your fluid with oil, flush the equipment with a compatible solvent before using the equipment. See **Maintenance**, page 13.

Trigger Lock

Always engage the trigger lock when you stop spraying to prevent the gun from being triggered accidentally by hand or if dropped or bumped.

Wet Cup

						
---	--	---	--	--	--	--

Before starting, fill wet cup (T) 1/3 full with Graco Throat Seal Liquid (TSL) or compatible solvent.

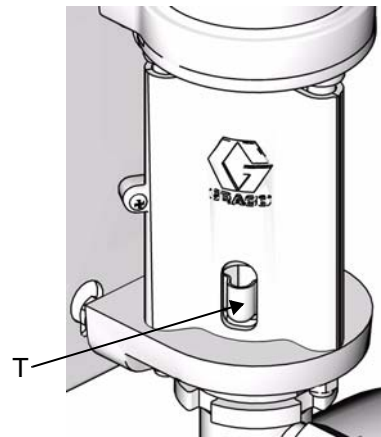

ti11927a

FIG. 4. Fill Wet Cup

Prime and Adjust the Pump

1. Lock gun trigger. Remove tip guard and spray tip from gun. Refer to gun manual.
2. Close gun air regulator and pump air regulator (H) by turning knobs counterclockwise reducing pressure to zero. Close bleed-type air valve (E). Also verify that all drain valves are closed.
3. Check that all fittings throughout system are tightened securely.
4. Position pail close to pump. Do not stretch suction hose tight/let it hang to assist fluid flow into pump.

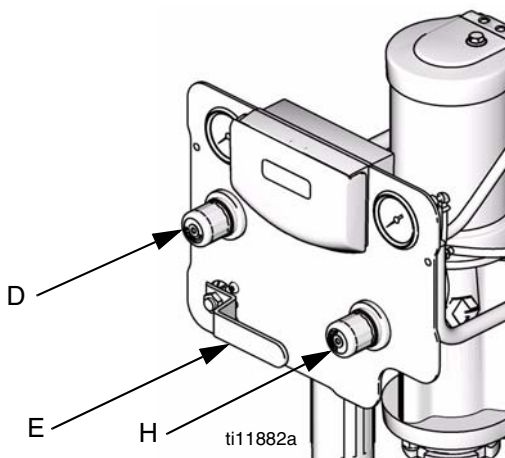

FIG. 5

5. Hold metal part of gun (L) firmly to side of grounded metal pail, unlock trigger, and hold trigger open.
6. *Pumps with runaway protection:* Enable the prime/flush function by pushing the prime/flush button on the DataTrak.
7. Open bleed-type air valve (E). Slowly open the pump air regulator (H) until the pump starts.
8. Cycle pump slowly until all air is pushed out and the pump and hoses are fully primed.
9. *Pumps with runaway protection:* Disable the prime/flush function by pushing the prime/flush button on the DataTrak.
10. Release gun trigger and lock trigger safety. Pump should stall against pressure.
11. With the pump and lines primed, and with adequate air pressure and volume supplied, the pump will start and stop as you open and close the gun/valve.

12. Use the air regulator to control the pump speed and the fluid pressure. Always use the lowest air pressure necessary to get the desired results. Higher pressures cause premature tip/nozzle and pump wear.

NOTICE

Never allow the pump to run dry of the fluid being pumped. A dry pump quickly accelerates to a high speed, possibly damaging itself. If your pump accelerates quickly, or is running too fast, stop it immediately and check the fluid supply. If the supply container is empty and air has been pumped into the lines, refill the container and prime the pump and the lines with fluid, or flush and leave it filled with a compatible solvent. Be sure to eliminate all air from the fluid system.

Shutdown and Care of the Pump

For a brief shutdown, relieve the pressure, page 11. Stop the pump at the bottom of its stroke to prevent fluid from drying on the exposed displacement rod and damaging the throat packings.

For a longer shutdown, or overnight, always flush the pump before the fluid dries on the displacement rod. Relieve the pressure, page 11.

Maintenance

Preventive Maintenance Schedule

The operating conditions of your particular system determine how often maintenance is required. Establish a preventive maintenance schedule by recording when and what kind of maintenance is needed, and then determine a regular schedule for checking your system.

Tighten Threaded Connections

Before each use, check all hoses for wear or damage. Replace as necessary. Check that all threaded connections are tight and leak-free.

Flush the Pump

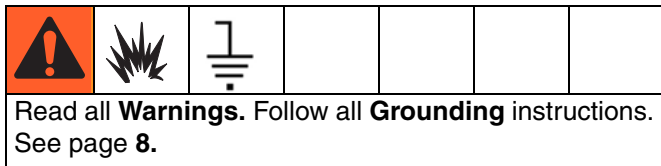

Flush the pump:

- Before first use
- When changing colors or fluids
- Before repairing equipment
- Before fluid dries or settles out in a dormant pump (check the pot life of catalyzed fluids)
- At the end of the day
- Before storing the pump.

Flush at the lowest pressure possible. Flush with a fluid that is compatible with the fluid you are pumping and with the wetted parts in your system. Check with your fluid manufacturer or supplier for recommended flushing fluids and flushing frequency.





1. Follow **Pressure Relief Procedure**, page 11.
2. Remove tip guard and spray tip from gun. Refer to separate gun manual.

3. Place siphon tube in grounded metal pail containing cleaning fluid.
4. Set pump to lowest possible fluid pressure, and start pump.
5. Hold a metal part of the gun firmly to a grounded metal pail.
6. *Units with runaway protection only:* enable the prime/flush function by pushing the prime/flush button on the DataTrak.
7. Trigger gun. Flush system until clear solvent flows from gun.
8. *Units with runaway protection only:* disable the prime/flush function by pushing the prime/flush button on the DataTrak.
9. Follow **Pressure Relief Procedure**, page 11.
10. Clean the tip guard, spray tip, and fluid filter element separately, then reinstall them.
11. Clean inside and outside of suction tube.

Wet Cup

Fill the wet cup one-half full with Graco Throat Seal Liquid (TSL). Maintain level daily.

Troubleshooting

						
<p>Relieve the pressure before checking or servicing the equipment.</p>						

NOTICE
<p>Check all possible problems and causes before disassembling the pump.</p>

Problem	Cause	Solution
Pump output low on both strokes.	Restricted air supply lines.	Clear any obstructions; be sure all shutoff valves are open; increase pressure, but do not exceed maximum working pressure.
	Exhausted fluid supply.	Refill and reprime pump.
	Clogged fluid outlet line, valves, etc.	Clear.
	Worn piston packing.	Replace. See displacement pump manual 312792.
Pump output low on only one stroke.	Held open or worn ball check valves.	Check and repair.
	Worn piston packings.	Replace.
No output.	Improperly installed ball check valves.	Check and repair.
Pump operates erratically.	Exhausted fluid supply.	Refill and reprime pump.
	Held open or worn ball check valves.	Check and repair.
	Worn piston packing.	Replace.
Pump will not operate.	Restricted air supply lines.	Clear any obstructions; be sure all shut off valves are open; increase pressure, but do not exceed maximum working pressure.
	Exhausted fluid supply.	Refill and reprime pump.
	Clogged fluid outlet line, valves, etc.	Clear.
	Damaged air motor.	See air motor manual 312796.
	Fluid dried on piston rod.	Disassemble and clean pump. See page 15 and manual 312792. In future, stop pump at bottom of stroke.
	Runaway solenoid has tripped.	Retract solenoid. See air motor manual 312796.

Repair

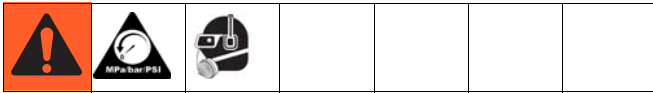

General Information

NOTICE

- Reference numbers and letters in parentheses in the text refer to the callouts in the figures and the parts drawing.
- Always use Genuine Graco Parts and Accessories, available from your Graco distributor. If you supply your own accessories, be sure they are adequately sized and pressure rated for your system.

Disconnect the Displacement Pump

1. Stop the pump in the middle of the stroke.
2. Flush the pump, if possible. (See page 13). Relieve the pressure. (See page 11).
3. Disconnect the air and fluid hoses and the ground wire (13).
4. Remove the tie rod shield (11).
5. Hold the flats of the air motor piston rod with a wrench. Use another wrench to loosen the coupling nut (9).

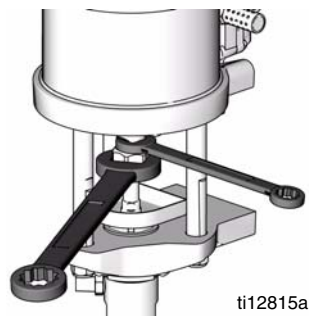

6. Lower the coupling nut (9) enough to remove the coupling collars (10), and then remove the coupling nut (9).

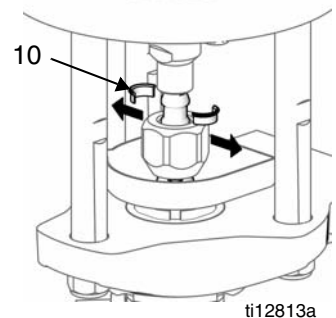
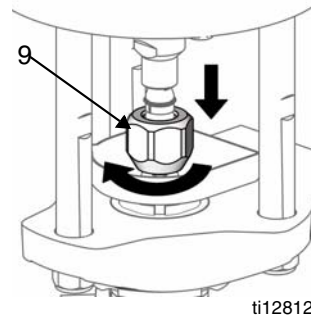

7. Pull up on TSL reservoir (7) to remove.

8. Use a hammer and brass rod to loosen the jam nut (4). Unscrew the jam nut as far as possible.

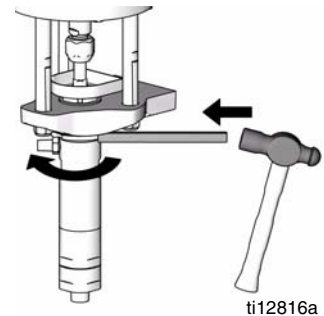

9. Unscrew the displacement pump by hand and place on work bench.

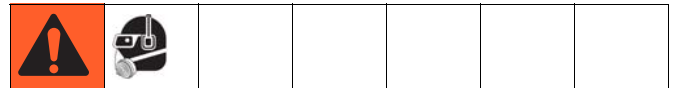

Threads are very sharp. Use a rag to protect hands when hand turning or carrying the pump.

Reconnect the Displacement Pump

1. Tilt the air motor onto its back, then hand turn the displacement pump into the adapter plate. Set the pump upright again.
2. Hold the air motor piston rod up with one hand. With your other hand, put the coupling nut (9) on the displacement rod.
3. Put the coupling collars (10) into the coupling nut (9) so large flanges point upward.
4. Gently let the air motor piston rod drop onto the displacement rod. Hand tighten the coupling nut (9).
5. Screw the displacement pump into the adapter plate (3) until the cylinder top is flush with the top of the adapter plate.

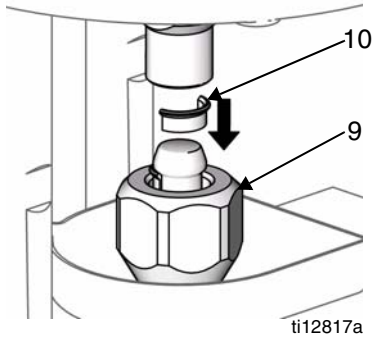

ti12817a

6. Align fluid outlet as shown and tighten the jam nut.
7. Align the TSL reservoir (7) and push it down into place.
8. Hold the flats of the motor rod with a wrench. Use another wrench to tighten the coupling nut (9). Torque according to the following table.

Displacement Pump	Torque
LW025A	23-26 ft-lb (31-35 N•m)
LW050A–LW150A	75-80 ft-lb (102-108 N•m)

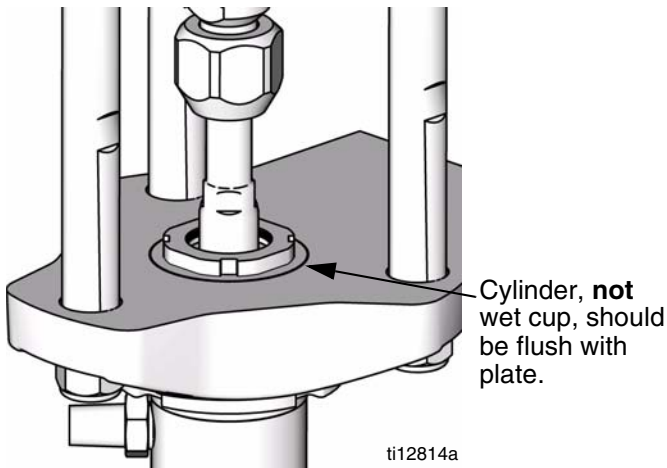

ti12814a

FIG. 6. Align cylinder and adapter plate.

Disconnect the Air Motor

1. Flush the pump, if possible. (See page 13.) Relieve the pressure. (See page 11.)
2. Disconnect the air and fluid hoses, the ground wire (13), and the tie rod shield (11).
3. Hold the flats of the air motor piston rod with a wrench. Use another wrench to loosen the coupling nut (9).
4. Use a socket to remove the tie rod nuts (6): 13 mm for M02xxx, 23 mm for all others.
5. Use a 13 mm socket to remove the top two mounting screws (MS).
6. Lift up on the air motor to remove it. The tie rods (5) and drip shield (12) will remain attached.

 **Cart Mount:** Remove the two screws on the arms and tip back or remove the air control panel for easier removal of the air motor.

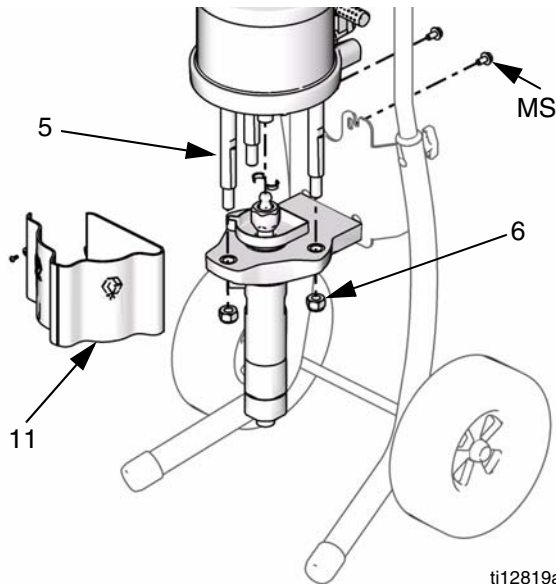

7. Slide the drip shield (12) off the tie rods (5).
8. Use a socket on the flats of the tie rods (5) to remove them from the bottom cover of the air motor.

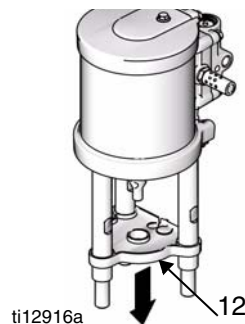

 See manual 312796 for air motor service and parts information,

Reconnect the Air Motor

1. Slide the drip shield (12) onto the tie rods (5).
2. Screw the tie rods (5) into the bottom cover of the air motor. Torque according to the following table:

Motor	Torque
M02xxx	5-10 ft-lb (7-13.5 N•m)
All Other Sizes	50-55 ft-lb (68-75 N•m)

3. As needed for the larger air motors, use two people to reattach. Align the tie rods (5) with the holes in the pump adapter (3). Carefully lower the air motor into place.
4. Attach the tie rod nuts (6) and torque according to the following table:

Motor	Torque
M02xxx	15-20 ft-lb (20-27 N•m)
All Other Sizes	50-60 ft-lb (68-81 N•m)

5. Tighten the mounting screws.
6. Hand tighten the coupling nut, then torque according to the following table:

Motor	Torque
M02xxx	23-26 ft-lb (31-35 N•m)
All Other Sizes	75-80 ft-lb (102-108 N•m)

7. Connect the air and fluid hoses, the ground wire, and the tie rod shield.

Pump Parts

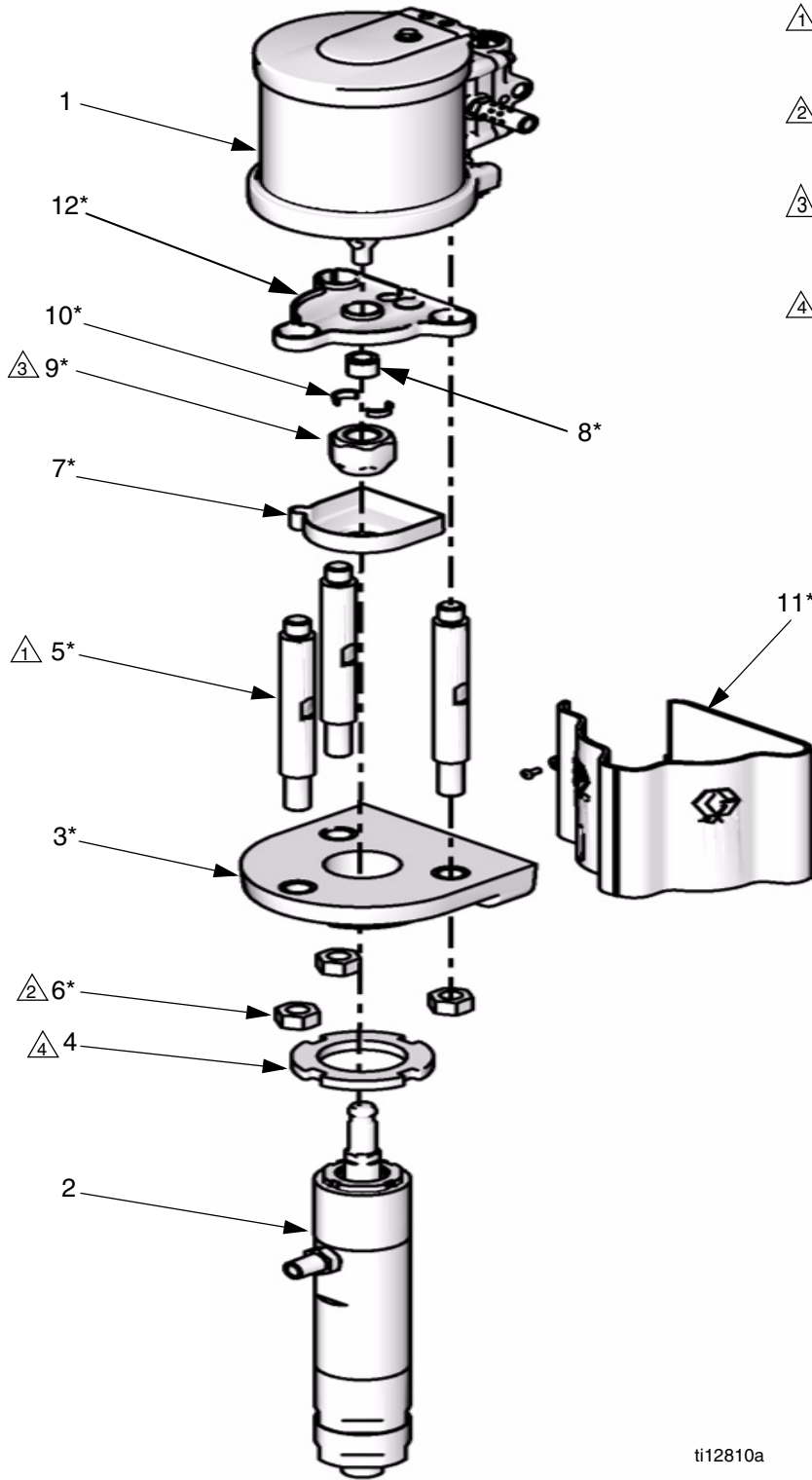

⚠️ 1 Torque varies by air motor size.
M02xxx: 5-10 ft-lb (7-13.5 N•m)
All others: 50-55 ft-lb (68-75 N•m)

⚠️ 2 Torque varies by air motor size.
M02xxx: 15-20 ft-lb (20-27 N•m)
All others: 50-60 ft-lb (68-81 N•m)

⚠️ 3 Torque varies by displacement
pump size.
25 cc: 23-26 ft-lb (31-35 N•m)
All others: 75-80 ft-lb (102-108

⚠️ 4 Torque to 70-75 ft-lb (95-102
N•m)

ti12810a

Ref.	Part No.	Description	Qty
1	See Table	MOTOR	1
2	See Table	DISPLACEMENT PUMP	1
3*	See Table	ADAPTER, pump	1
4	See Table	NUT, jam	1
5*	15M661 15M662	ROD, tie M02xxx motor All other motor sizes	3 3
6*	104541 15U606	NUT, tie rod M02xxx motor All other motor sizes	3 3
7*	See Table	RESERVOIR, TSL	1
8*	See Table	ADAPTER, 1/2-20 ID X M22 x 1.5 OD	
9*	15M758 15T311	NUT, coupling LW025x displacement pumps All other pump sizes	1 1

Ref.	Part No.	Description	Qty
10*	-----	COLLAR, coupling; see page 20 to order package of 10	2
11*	See Table	SHIELD, tie rod	1
12*	See Table	SHIELD, drip	1
13*	238909	WIRE, grounding assembly, not shown	1

----- Not sold separately.

* Included in Connecting Kit. See page 20 to order the correct kit for your pump.

NOTE: Replacement Warning labels, signs, tags, and cards are available at no cost.

Parts That Vary by Model

Model	Motor (1)	Motor Piston Diam. (in.)	Displacement Pump (2)	Pump Adapter (3)	Jam Nut (4)	TSL Reservoir (7, includes o-ring)	Adapter (8)	Tie Rod Shield (11, includes screw)	Drip Shield (12)
W10CAS	M04LN0	3.5	LW075A	15R978	24A636	24A623	15M675	24A958	15T462
W10CBS	M04LT0								
W15AAS	M02LN0	2.5	LW025A	15R862	24A634	24A620		24A957	15T461
W15AES									
W15BAS	M04LN0	3.5	LW050A	15R977	24A635	24A622	15M675	24A958	15T462
W15BBS	M04LT0								
W15FAS	M12LN0	6.0	LW150A	15T395	24A639	24A628		24A959	15V028
W15FBS	M12LT0								
W18EAS	M12LN0	6.0	LW125A	15T394	24A638	24A627		24A959	15V028
W18EBS	M12LT0								
W23DAS	M12LN0	6.0	LW100A	15T393	24A637	24A626		24A959	15V028
W23DBS	M12LT0								
W24FAS	M18LN0	7.5	LW150A	15T395	24A639	24A628		24A959	15V028
W24FBS	M18LT0								
W28EAS	M18LN0	7.5	LW125A	15T394	24A638	24A627		24A959	15V028
W28EBS	M18LT0								
W30AAS	M04LN0	3.5	LW025A	15R863	24A634	24A621		24A958	15T462
W30ABS	M04LT0								
W30CAS	M12LN0	6.0	LW075A	15T392	24A636	24A625		24A959	15V028
W30CBS	M12LT0								
W36DAS	M18LN0	7.5	LW100A	15T393	24A637	24A626		24A959	15V028
W36DBS	M18LT0								
W45BAS	M12LN0	6.0	LW050A	15T391	24A635	24A624		24A959	15V028
W45BBS	M12LT0								
W48CAS	M18LN0	7.5	LW075A	15T392	24A636	24A625		24A959	15V028
W48CBS	M18LT0								

Repair Kits

Kit Description	LW025A		LW050A		LW075A		LW100A	LW125A	LW150A
	2.5 in. motor	3.5 in. motor	3.5 in. motor	6-7.5 in motor	3.5 in. motor	6-7.5 in motor			
Wet-Cup O-Ring Package of 10	24A630		24A631		24A631		24A632	24A633	24A633
Coupling Collars (10) Package of 10	24A618		24A619		24A619		24A619	24A619	24A619
Connecting Kit Includes pump adapter (3), three tie rods (5), three tie rod nuts (6), TSL reservoir and o-ring (7), adapter (8), coupling nut (9), two coupling collars (10), tie rod shield and screw (11), and drip shield (12).	24A281	24A282	24A283	24A285	24A284	24A286	24A287	24A288	24A289

NOTE:

For **displacement pump repair kits**, see manual 312792.

For **air motor repair kits**, see manual 312796.

Performance Charts

Model W10xxx

10:1 Ratio, 75 cc/cycle

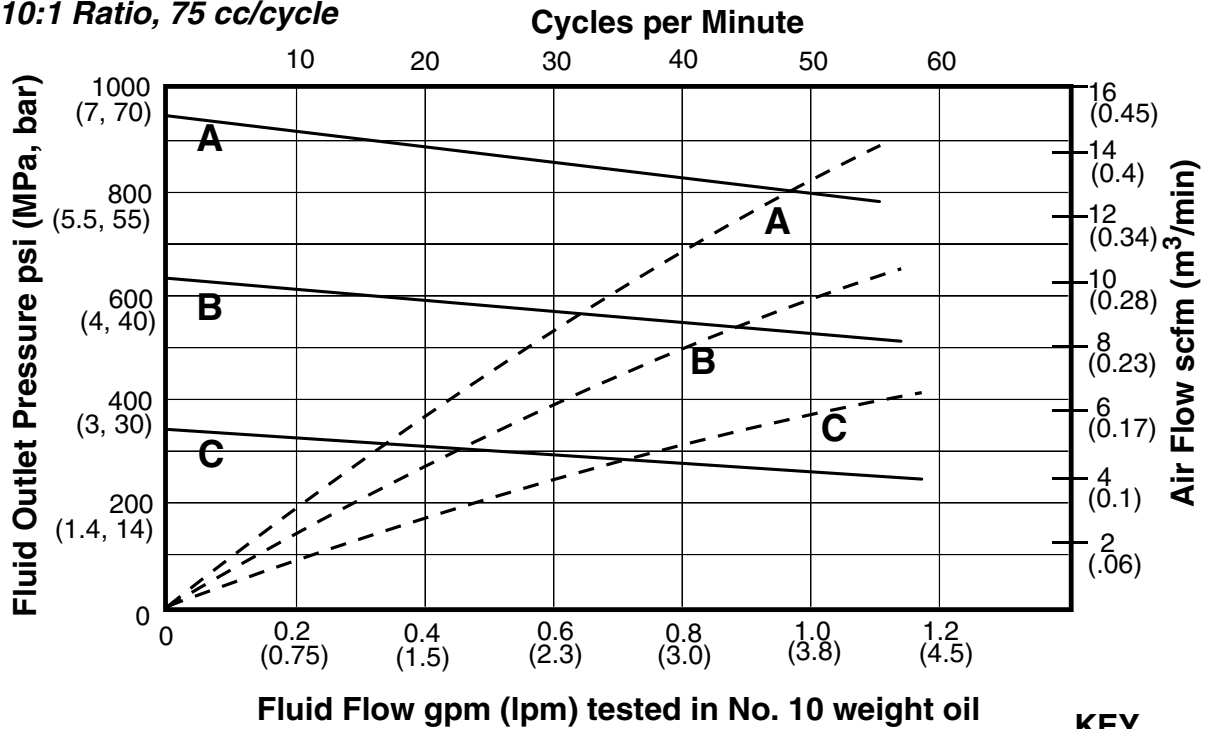

KEY

- A** = 100 psi (0.7 MPa, 7 bar)
- B** = 70 psi (0.5 MPa, 5 bar)
- C** = 40 psi (0.3 MPa, 3 bar)
- = fluid flow
- - - = air consumption

Model W15Axx

15:1 Ratio, 25 cc/cycle

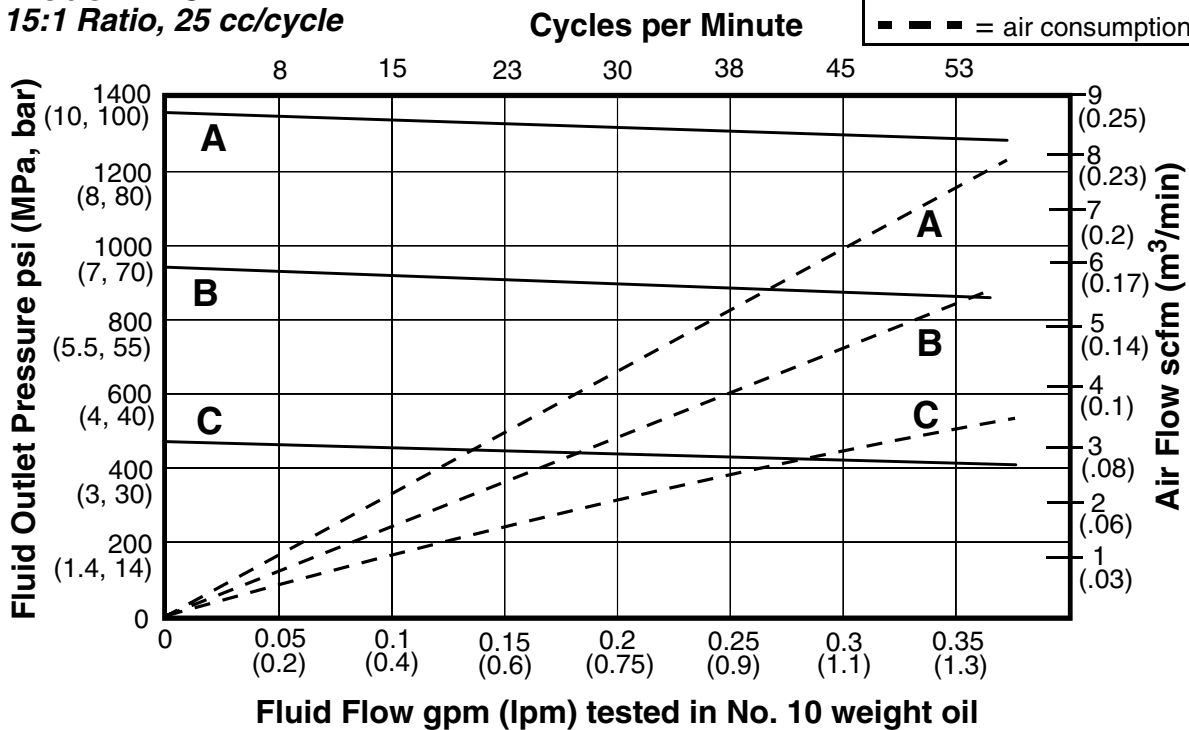

Model W15Bxx
15:1 Ratio, 50 cc/cycle

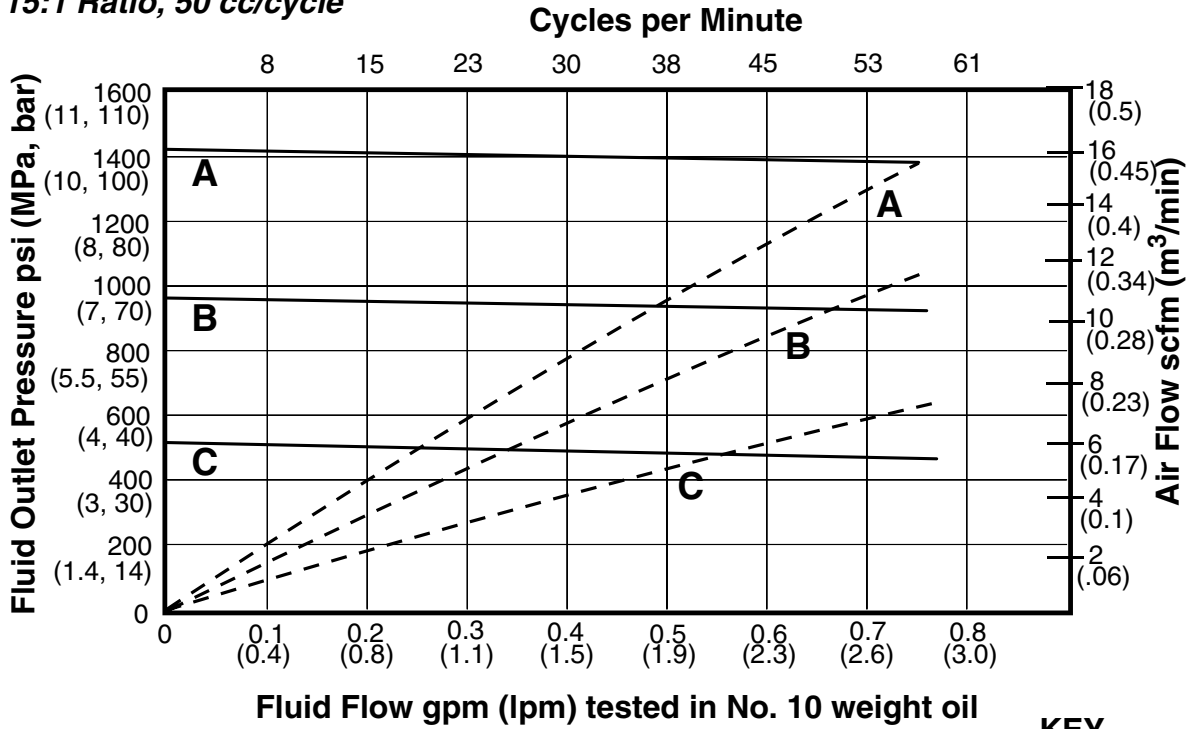

Model W15Fxx
15:1 Ratio, 150 cc/cycle

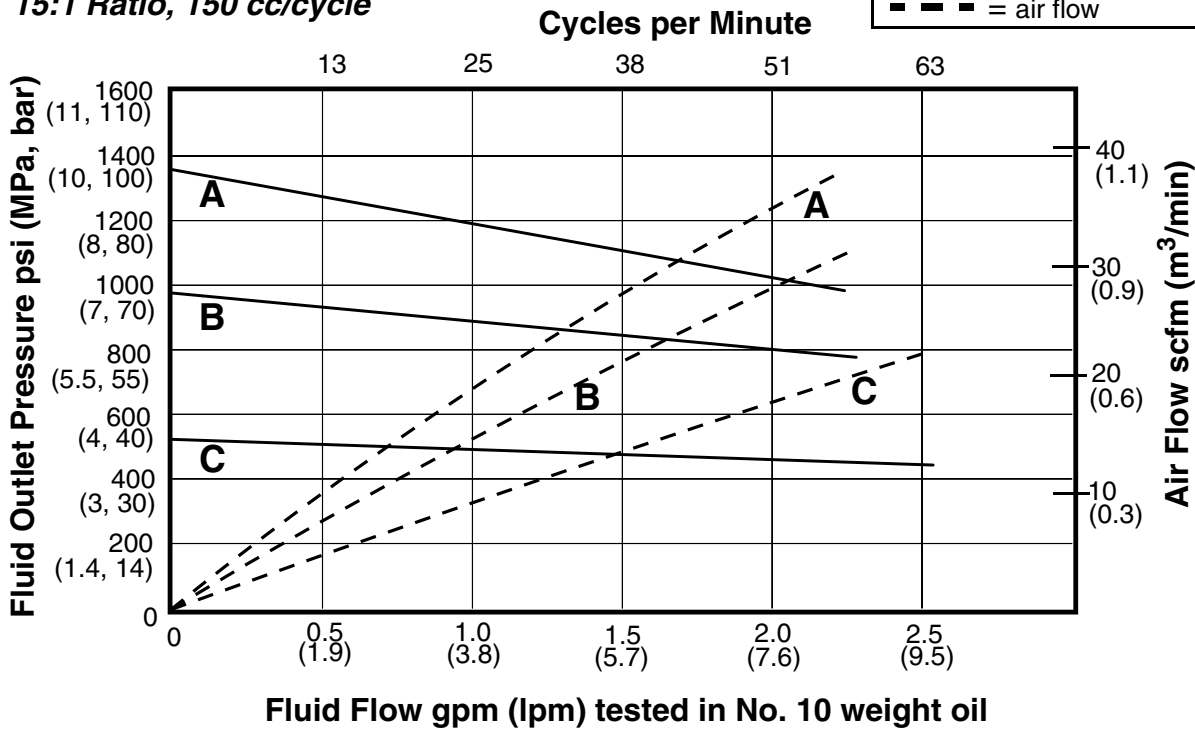

Model W18xxx
18:1 Ratio, 125 cc/cycle

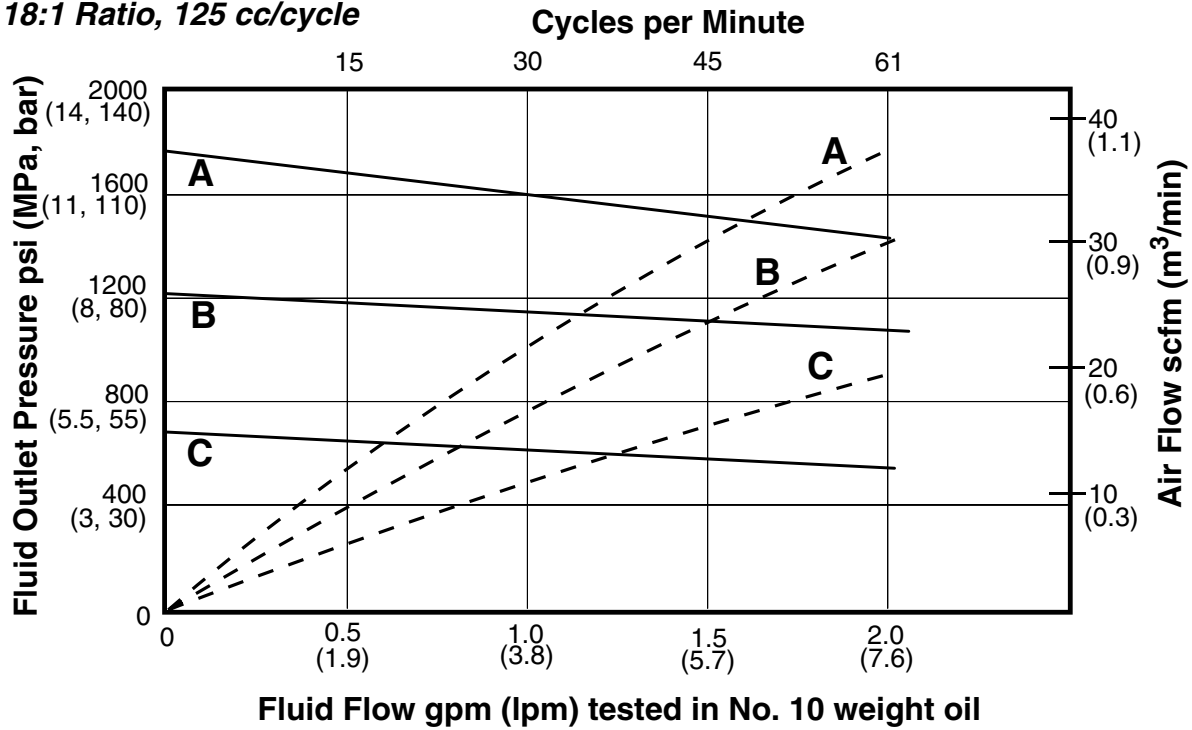

KEY

A	= 100 psi (0.7 MPa, 7 bar)
B	= 70 psi (0.5 MPa, 5 bar)
C	= 40 psi (0.3 MPa, 3 bar)
—	= fluid flow
- - -	= air flow

Model W23xxx
23:1 Ratio, 100 cc/cycle

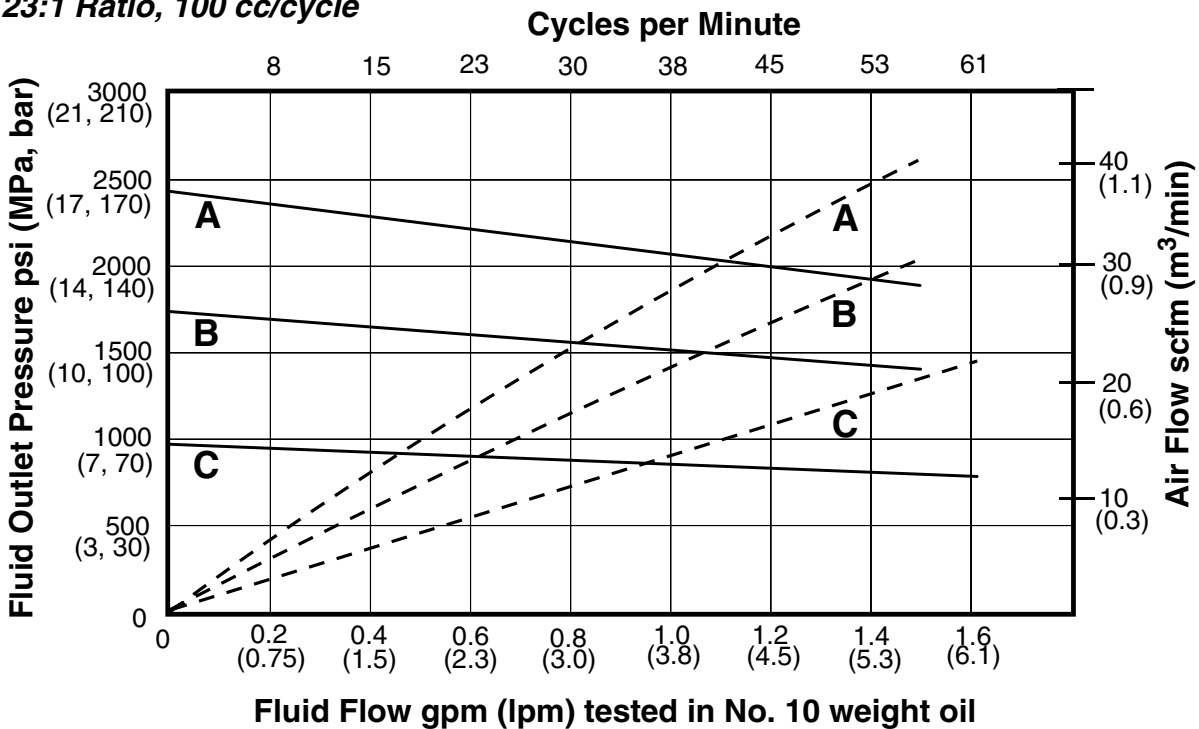

Model W24xxx
24:1 Ratio, 150 cc/cycle

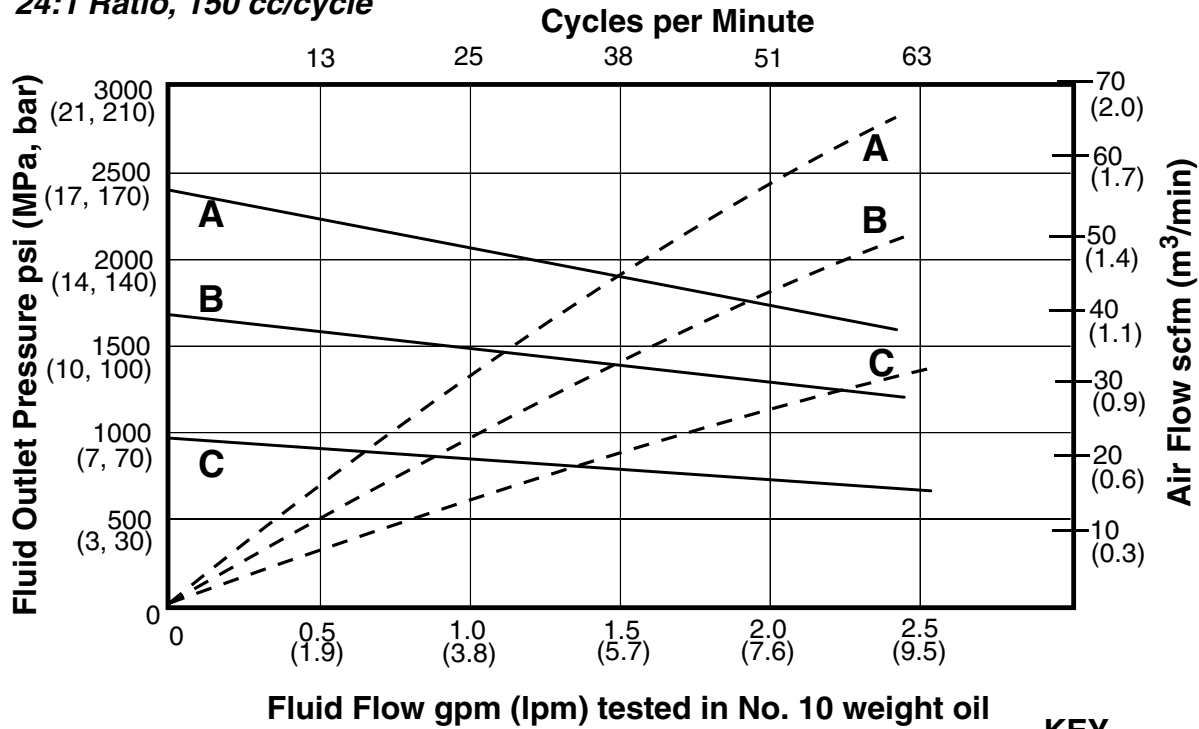

KEY

- A** = 100 psi (0.7 MPa, 7 bar)
- B** = 70 psi (0.5 MPa, 5 bar)
- C** = 40 psi (0.3 MPa, 3 bar)
- = fluid flow
- - - = air flow

Model W28xxx
28:1 Ratio, 125 cc/cycle

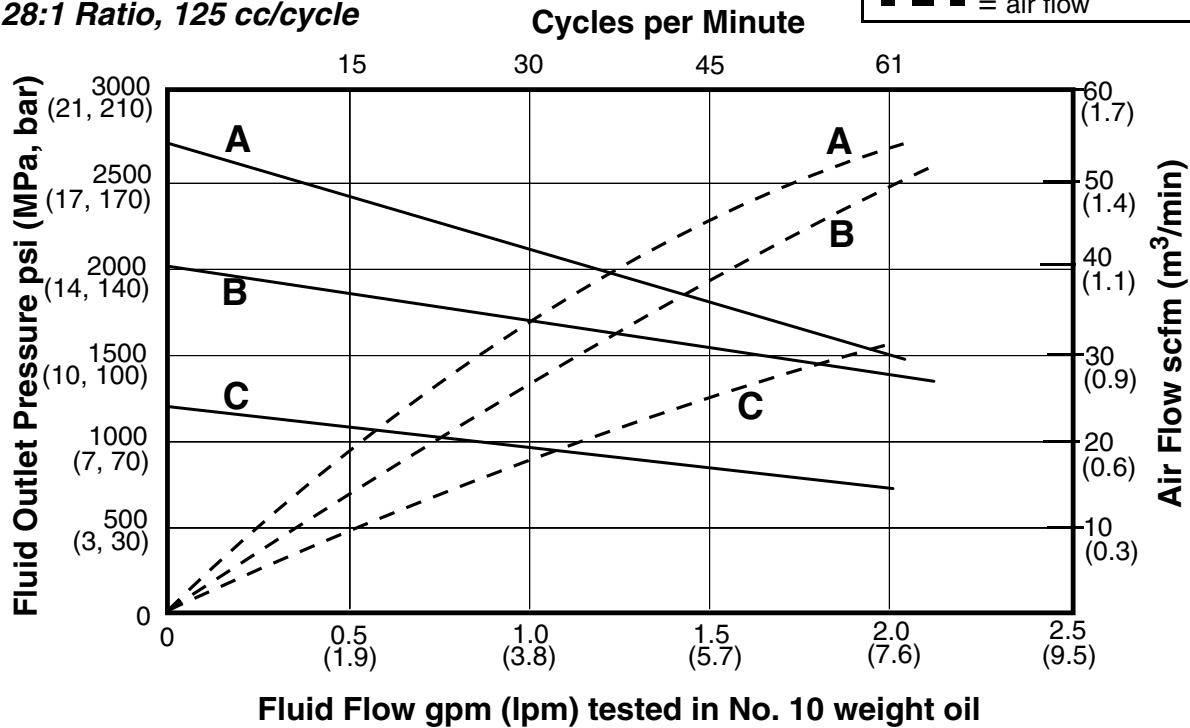

Model W30Axx
30:1 Ratio, 25 cc/cycle

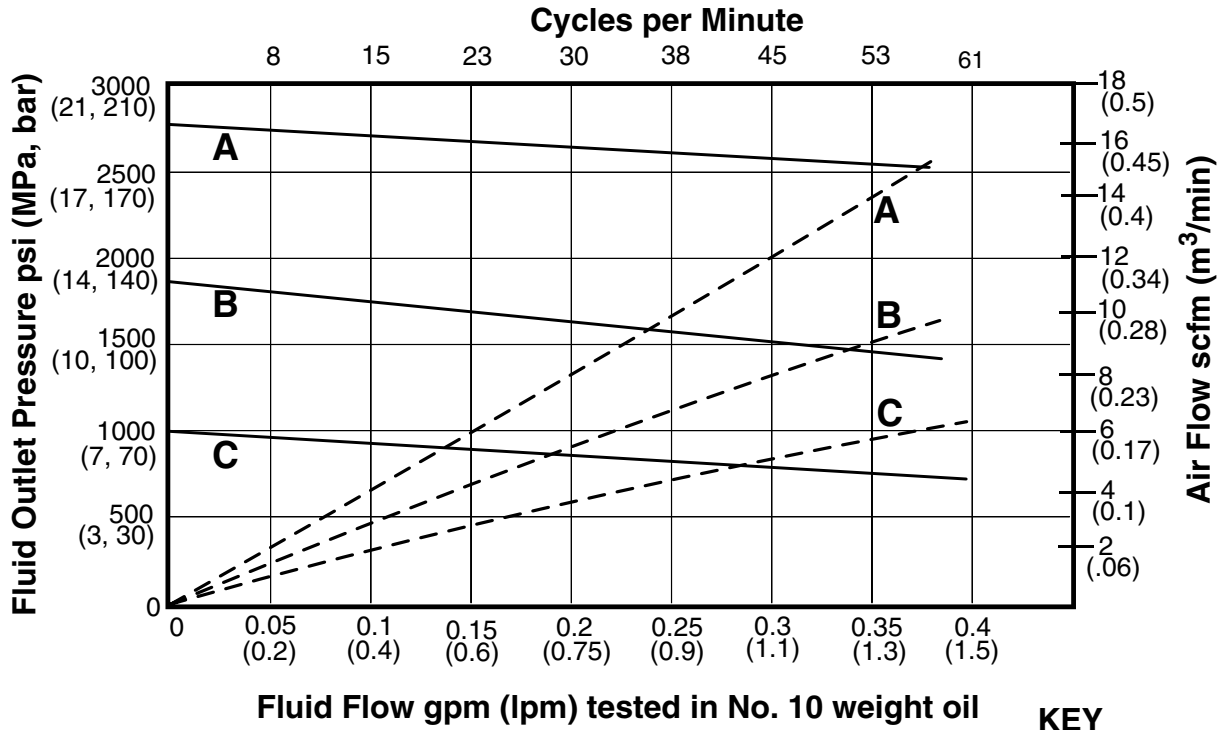

Model W30Cxx
30:1 Ratio, 75 cc/cycle

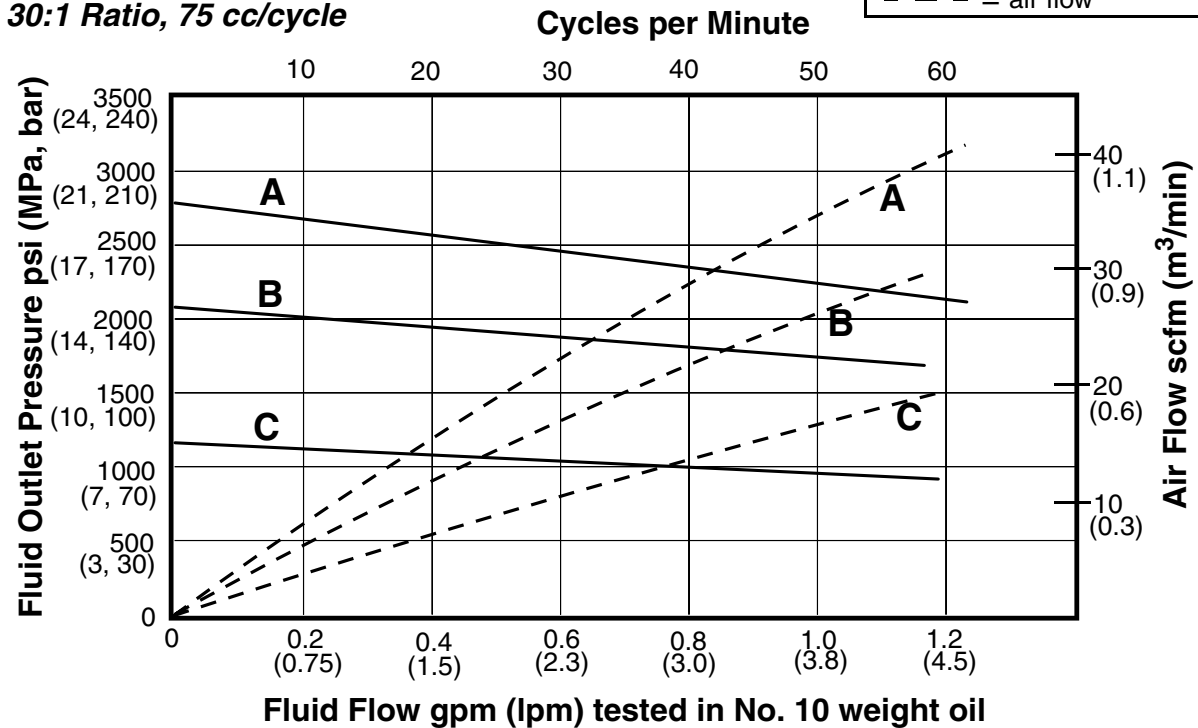

Model W36xxx
36:1 Ratio, 100 cc/cycle

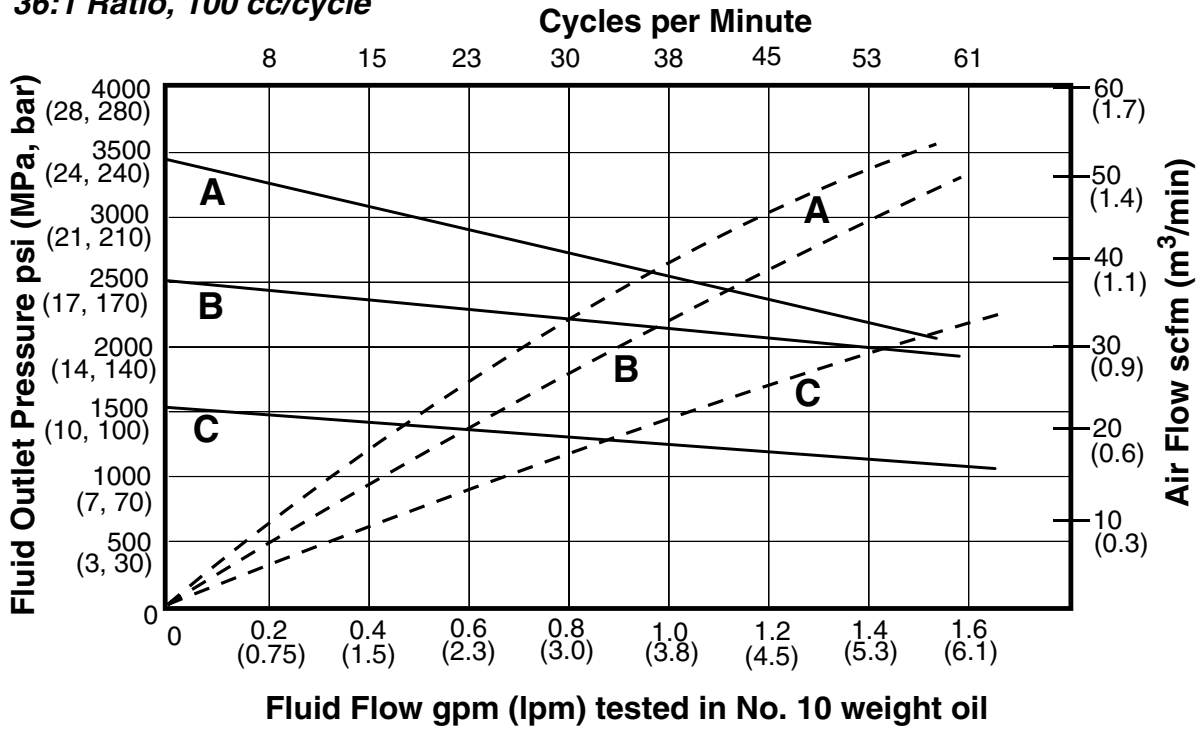

KEY

- A** = 100 psi (0.7 MPa, 7 bar)
- B** = 70 psi (0.5 MPa, 5 bar)
- C** = 40 psi (0.3 MPa, 3 bar)
- = fluid flow
- - - = air flow

Model W45xxx
45:1 Ratio, 50 cc/cycle

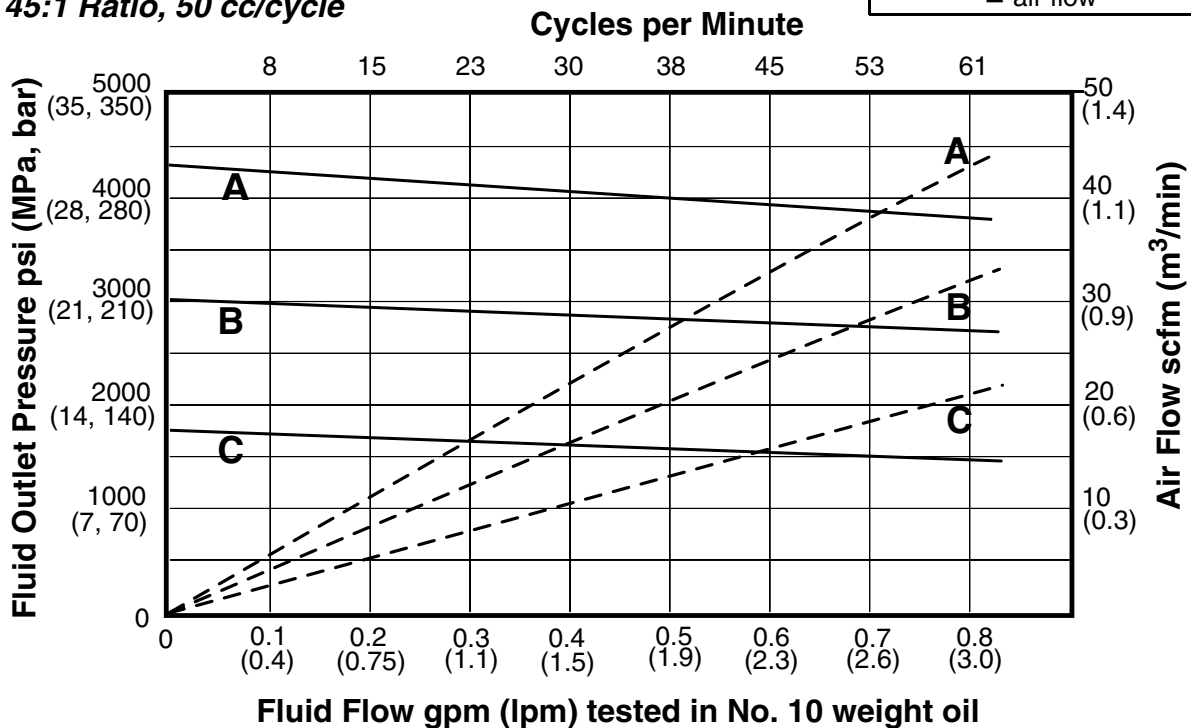

Model W48xxx
48:1 Ratio, 75 cc/cycle

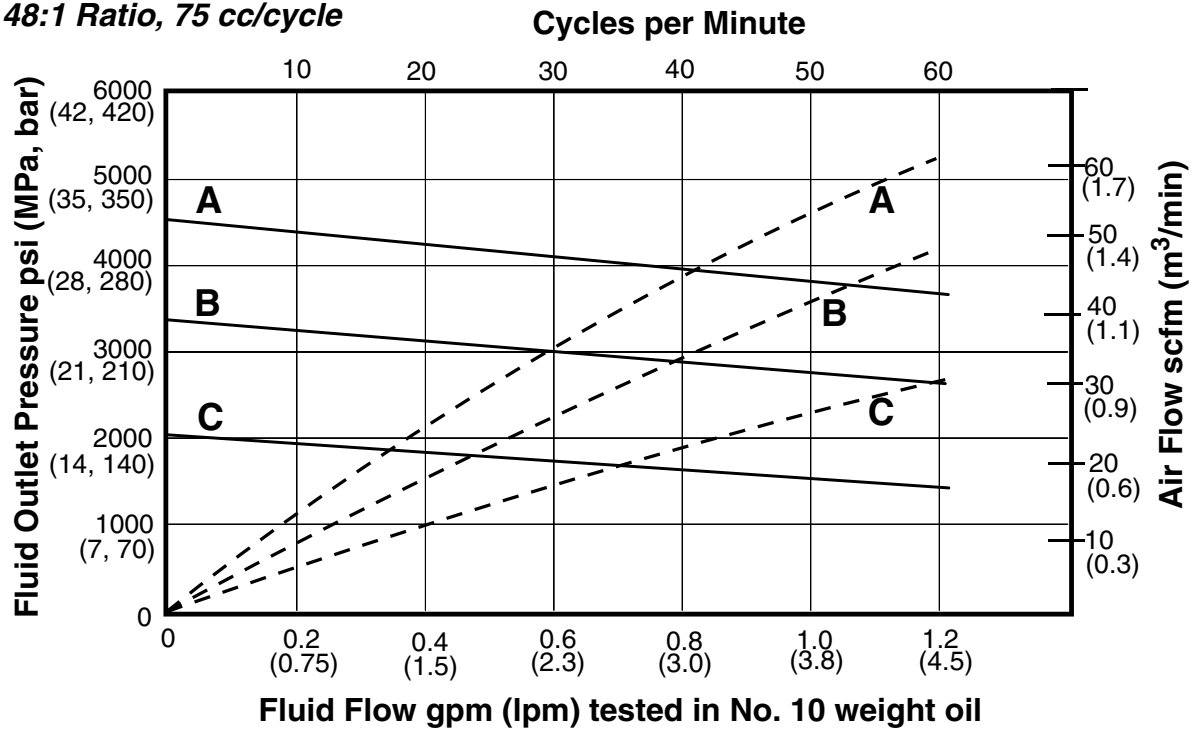

KEY

- A** = 100 psi (0.7 MPa, 7 bar)
- B** = 70 psi (0.5 MPa, 5 bar)
- C** = 40 psi (0.3 MPa, 3 bar)
- = fluid flow
- - - = air flow

Pump Dimensions

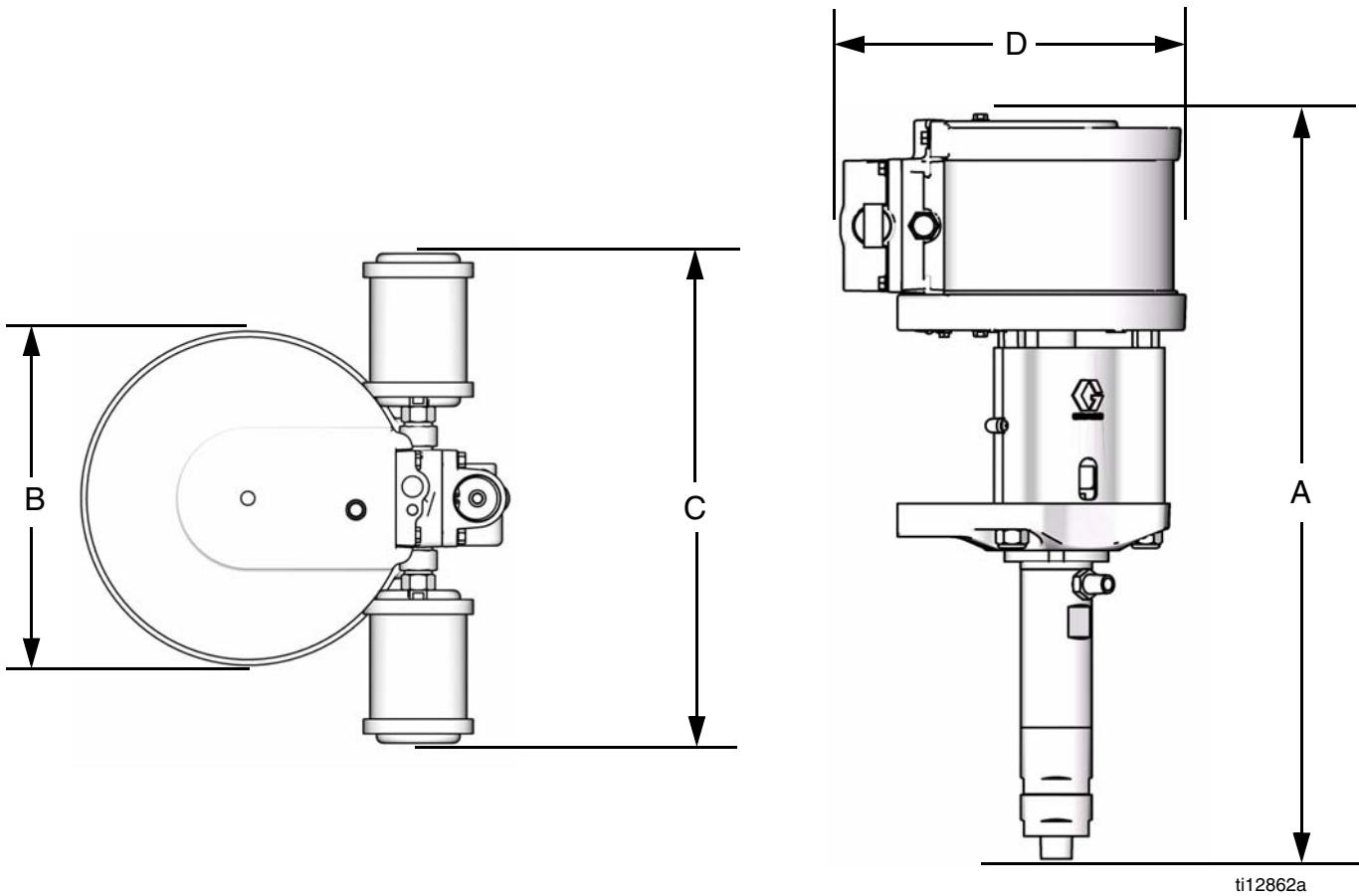

Pump Model	A in. (mm)	B in. (mm)	C in (mm)	D in (mm)	Weight lbs (kg)
W10xxx	24.6 (625)	5.6 (142)	5.8 (147)	7.8 (198)	30 (14)
W15Axx	24.1 (612)	4.2 (107)	5.1 (130)	6.2 (157)	15 (7)
W15Bxx	24.0 (610)	5.6 (142)	5.8 (147)	7.8 (198)	28 (13)
W15Fxx	25.2 (640)	8.6 (218)	11.7 (297)	11.4 (290)	61 (28)
W18xxx	25.2 (640)	8.6 (218)	11.7 (297)	11.4 (290)	61 (28)
W23xxx	25.1 (638)	8.6 (218)	11.7 (297)	11.4 (290)	59 (27)
W24xxx	25.2 (640)	10.1 (257)	14.8 (375)	12.9 (328)	64 (29)
W28xxx	25.2 (640)	10.1 (257)	14.8 (375)	12.9 (328)	64 (29)
W30Axx	24.1 (612)	5.6 (142)	5.8 (147)	7.8 (198)	22 (10)
W30Cxx	25.0 (635)	8.6 (218)	11.7 (297)	11.4 (290)	56 (26)
W36xxx	25.1 (638)	10.1 (257)	14.8 (375)	12.9 (328)	62 (28)
W45xxx	24.5 (622)	8.6 (218)	11.7 (297)	11.4 (290)	54 (25)
W48xxx	25 (635)	10.1 (257)	14.8 (375)	12.9 (328)	59 (27)

Wall Bracket Mounting Dimensions

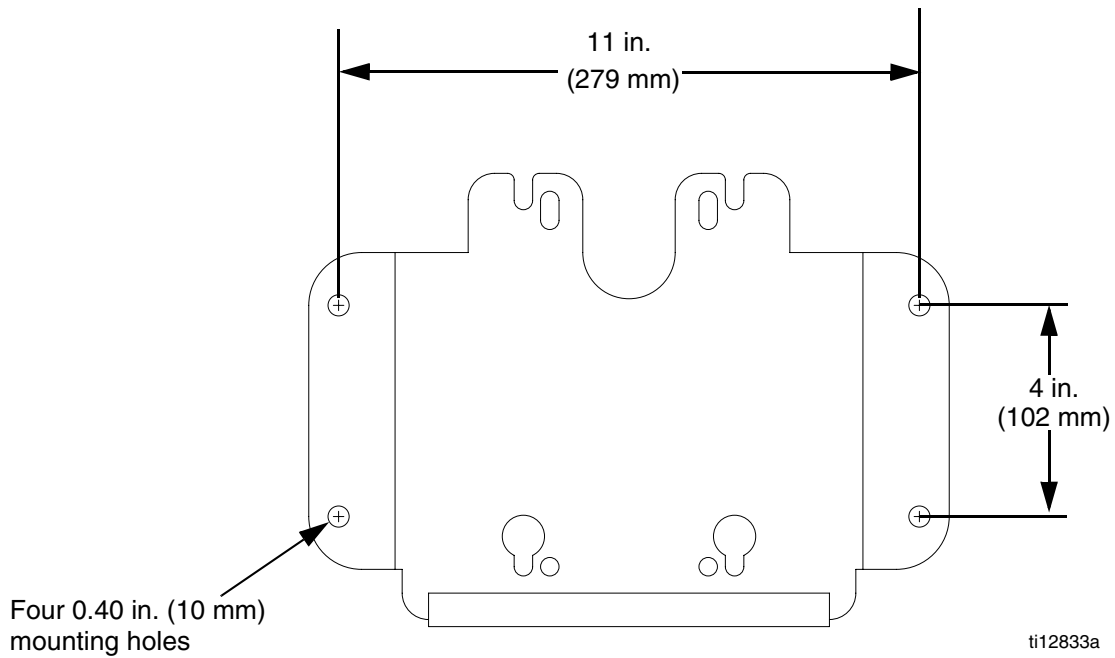

Technical Data

Maximum fluid working pressure	See Models, page 4
Maximum air inlet pressure	See Models, page 4
Minimum air inlet pressure	10 psi (0.07 MPa, 0.7 bar)
Air consumption	See Performance Charts
Fluid flow at 60 cycles per minute	See Models, page 4
Maximum fluid temperature rating	160°F (71°C)
Stroke length	2.5 in. (63.5 mm)
Sound data	See Technical Data in air motor manual 312796.

Graco Standard Warranty

Graco warrants all equipment referenced in this document which is manufactured by Graco and bearing its name to be free from defects in material and workmanship on the date of sale to the original purchaser for use. With the exception of any special, extended, or limited warranty published by Graco, Graco will, for a period of twelve months from the date of sale, repair or replace any part of the equipment determined by Graco to be defective. This warranty applies only when the equipment is installed, operated and maintained in accordance with Graco's written recommendations.

This warranty does not cover, and Graco shall not be liable for general wear and tear, or any malfunction, damage or wear caused by faulty installation, misapplication, abrasion, corrosion, inadequate or improper maintenance, negligence, accident, tampering, or substitution of non-Graco component parts. Nor shall Graco be liable for malfunction, damage or wear caused by the incompatibility of Graco equipment with structures, accessories, equipment or materials not supplied by Graco, or the improper design, manufacture, installation, operation or maintenance of structures, accessories, equipment or materials not supplied by Graco.

This warranty is conditioned upon the prepaid return of the equipment claimed to be defective to an authorized Graco distributor for verification of the claimed defect. If the claimed defect is verified, Graco will repair or replace free of charge any defective parts. The equipment will be returned to the original purchaser transportation prepaid. If inspection of the equipment does not disclose any defect in material or workmanship, repairs will be made at a reasonable charge, which charges may include the costs of parts, labor, and transportation.

THIS WARRANTY IS EXCLUSIVE, AND IS IN LIEU OF ANY OTHER WARRANTIES, EXPRESS OR IMPLIED, INCLUDING BUT NOT LIMITED TO WARRANTY OF MERCHANTABILITY OR WARRANTY OF FITNESS FOR A PARTICULAR PURPOSE.

Graco's sole obligation and buyer's sole remedy for any breach of warranty shall be as set forth above. The buyer agrees that no other remedy (including, but not limited to, incidental or consequential damages for lost profits, lost sales, injury to person or property, or any other incidental or consequential loss) shall be available. Any action for breach of warranty must be brought within two (2) years of the date of sale.

GRACO MAKES NO WARRANTY, AND DISCLAIMS ALL IMPLIED WARRANTIES OF MERCHANTABILITY AND FITNESS FOR A PARTICULAR PURPOSE, IN CONNECTION WITH ACCESSORIES, EQUIPMENT, MATERIALS OR COMPONENTS SOLD BUT NOT MANUFACTURED BY GRACO. These items sold, but not manufactured by Graco (such as electric motors, switches, hose, etc.), are subject to the warranty, if any, of their manufacturer. Graco will provide purchaser with reasonable assistance in making any claim for breach of these warranties.

In no event will Graco be liable for indirect, incidental, special or consequential damages resulting from Graco supplying equipment hereunder, or the furnishing, performance, or use of any products or other goods sold hereto, whether due to a breach of contract, breach of warranty, the negligence of Graco, or otherwise.

FOR GRACO CANADA CUSTOMERS

The Parties acknowledge that they have required that the present document, as well as all documents, notices and legal proceedings entered into, given or instituted pursuant hereto or relating directly or indirectly hereto, be drawn up in English. Les parties reconnaissent avoir convenu que la rédaction du présente document sera en Anglais, ainsi que tous documents, avis et procédures judiciaires exécutés, donnés ou intentés, à la suite de ou en rapport, directement ou indirectement, avec les procédures concernées.

Graco Information

For the latest information about Graco products, visit www.graco.com.

TO PLACE AN ORDER, contact your Graco distributor or call to identify the nearest distributor.

Phone: 612-623-6921 **or Toll Free:** 1-800-328-0211 **Fax:** 612-378-3505

*All written and visual data contained in this document reflects the latest product information available at the time of publication.
Graco reserves the right to make changes at any time without notice.*

This manual contains English. MM 312794

Graco Headquarters: Minneapolis
International Offices: Belgium, China, Japan, Korea

GRACO INC. P.O. BOX 1441 MINNEAPOLIS, MN 55440-1441

Copyright 2008, Graco Inc. is registered to ISO 9001

www.graco.com
Revised 2/2009