

INSTRUCTIONS-PARTS LIST



308060

Rev. J



This manual contains important warnings and information.
READ AND KEEP FOR REFERENCE.

INSTRUCTIONS

First choice when quality counts.™

STAND PIPE MOUNTED; CORROSION-RESISTANT OR WATERBORNE **Crown Imperial Pumps**

250 psi (1.7 MPa, 17 bar) Maximum Working Pressure

**Electric, Multi-Stage, Centrifugal,
Stand Pipe Mounted Pumps for Circulating Systems with
60 in. (1.5 m) Maximum Tank Height**

**Motor
Not Included
with Pump**

PUMP MODEL CHART

No. of Stages	Corrosion Resistant Standard size for 60 in. (152cm) max. tank height	Waterborne Standard size for 60 in. (152 cm) max. tank height
	Model No.	Model No.
6	223806	223706
7	223807	223707
8	223808	223708
9	223809	223709
10	223810	223710
11	223811	223711
12	223812	223712
13	223813	223713
14	223814	223714
15	NONE	237015

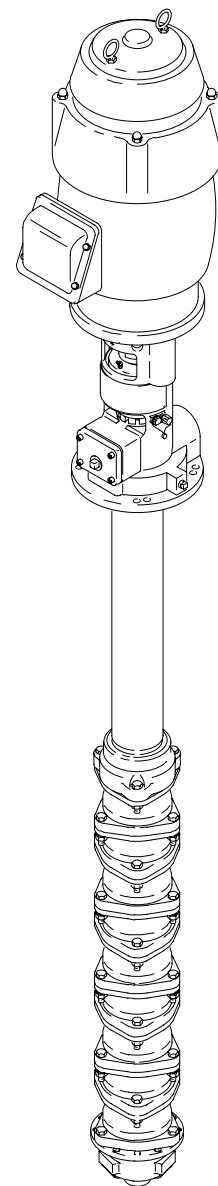

TI0571B

STANDPIPE

66 in. (1.7 m) high. Purchase separately.

Diameter	Stainless Steel Model No.	Carbon Steel Model No.
8 in. (203 mm)	208995	214644
11 in. (279 mm)	904628*	903683*

* Adapter plate 903688 is required with this stand.
Order separately.

GRACO INC. P.O. BOX 1441 MINNEAPOLIS, MN 55440-1441

©COPYRIGHT 1990, GRACO INC.

Graco Inc. is registered to I.S. EN ISO 9001



HO03

Table of Contents

Warnings	2
Installation	4
Operation	7
Lubrication	9
Preventive Maintenance	9
Troubleshooting	10
Service	12
Parts	20
Dimensions	24
Accessories	26
Technical Data	29
Warranty	30
Phone Numbers	30

Symbols

Warning Symbol



This symbol alerts you to the possibility of serious injury or death if you do not follow the instructions.

Caution Symbol



This symbol alerts you to the possibility of damage to or destruction of equipment if you do not follow the corresponding instructions.

WARNING



INSTRUCTIONS

EQUIPMENT MISUSE HAZARD

Equipment misuse can cause the equipment to rupture or malfunction and result in serious injury.

- This equipment is for professional use only.
- Read all instruction manuals, tags, and labels before operating the equipment.
- Use the equipment only for its intended purpose. If you are not sure, call your Graco distributor.
- Do not alter or modify this equipment.
- Check equipment daily. Repair or replace worn or damaged parts immediately.
- Do not exceed the maximum working pressure of the lowest rated system component. Refer to the **Technical Data** on page 29 for the maximum working pressure of this equipment.
- Use fluids and solvents which are compatible with the equipment wetted parts. Refer to the **Technical Data** section of all equipment manuals. Read the fluid and solvent manufacturer's warnings.
- Wear hearing protection when operating this equipment.
- Comply with all applicable local, state, and national fire, electrical, and safety regulations.



FIRE, EXPLOSION, AND ELECTRIC SHOCK HAZARD

Improper grounding, poor ventilation, open flames or sparks can cause a hazardous condition and result in a fire or explosion and serious injury.

- Ground the equipment. Refer to **Grounding** on page 5.
- If there is any static sparking or you feel an electric shock while using this equipment, **stop spraying immediately**. Do not use the equipment until you identify and correct the problem.
- Provide fresh air ventilation to avoid the buildup of flammable fumes from solvents or the fluid being sprayed.
- Consult the electric motor manufacturer for the proper heater-breaker requirements.



MOVING PARTS HAZARD

Moving parts in the pump housing can pinch or amputate your fingers.

- Keep clear of all moving parts when starting or operating the pump.
- Keep all tools, etc. away from the moving parts to reduce the risk of accidentally catching and breaking them.
- Before servicing the equipment, shut off the electric power, **relieve the pressure**, and drain the pump by opening the drain valve at the pump base.



HOT SURFACE HAZARD

- The pump housing and pump shaft couplers become hot during operation. To reduce the risk of burning yourself, do not touch them until they have cooled.

Installation

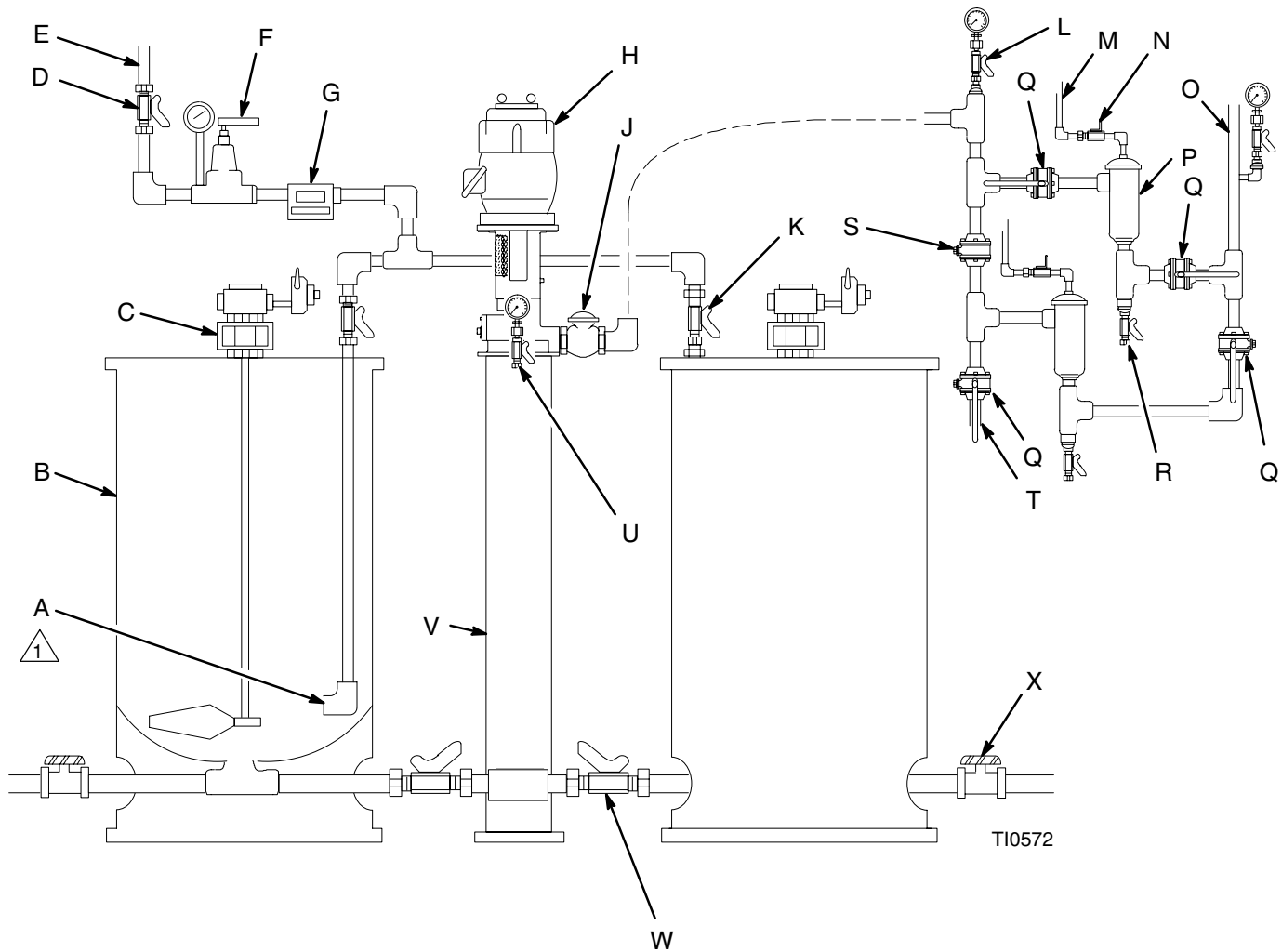

TI0572

KEY

A Elbow	H Motor	N Air Blowdown Valve	T To Standby Pump
B Mix Tank	J Check Valve	O To Spray Booth	U Outlet Pressure Gauge with Drain Valve
C Agitator	K Tank Shutoff Valve	P Fluid Filter	V Standpipe
D Shutoff Valve, Return Line	L Pressure Gauge with Pulsation Dampener and Isolation Valve	Q Line Isolation Valve	W Outlet Shutoff Valve
E Return Line	M Open to Air	R Filter Drain Valve	X Tank Drain Valve
F Back Pressure Valve		S Standby Pump/System Blow-down Connection Valve	
G Flow Meter			

1 To minimize turbulence, extend return line to bottom of tank and use elbow to direct flow around perimeter of tank.

Fig. 1

Installation

Grounding

WARNING

Ground the pump in accordance with all applicable safety codes in your area. Proper grounding reduces the risk of shock, fire, or explosion caused by static sparking, which can result in serious injury and property damage.

1. Have a licensed electrician complete the electrical hookup and wiring.
2. Consult the electric motor manufacturer for proper heater-breaker requirements.
3. Before coupling the pump coupler to the motor shaft coupler, check to be sure the shaft rotates in the proper direction. Refer to Fig. 2, page 6.

System Design

The **Typical Installation** shown on page 4, and the following text, is only a guide to show the relationship of the pump to other system components. Due to the pressure characteristics of the pump, which vary widely with viscosity and specific gravity, professional systems design is essential. Contact Graco (see back page) for further information.

Pump dimensions and the mounting hole layout are shown on page 24. The **Technical Data** is given on page 29.

Fluid Lines

Line sizes depend on the flow requirements and calculated pressure drop due to the length of the run.

The pipe, tubing and fittings must be compatible with the fluid and solvent you plan to use.

Keep in mind that sharp corners and fittings between lengths of pipe or tubing may cause flow restrictions and fluid breakdown. Use the longest lengths of pipe or tubing available to minimize couplings. Use the most direct route to the spray stations, and whenever practical, use long sweeping bends. A “holsclaw” bender is recommended for making bends in tubing; a common electrician’s or plumber’s bender is not satisfactory.

Remove burrs, dirt and contaminants from the ends of the tubes before installing the fittings.

Return Line

Install a back pressure valve (F) to maintain proper line pressure to all outlets. Install a flow meter (G) to visually check the fluid flow rate.

Extend the return line (E) going into the mix tank (B) to the bottom of the tank and end it with an elbow (A). The elbow directs fluid around the walls of the tank to help minimize air entrainment in the fluid.

Supply Line

Install a line check valve (J) near the 2 in. npt(f) pump outlet.

CAUTION

The line check valve (J) is required to prevent fluid backflow into the pump in case of a power failure or incorrect operating procedure.

Install a pressure gauge (G) at the plugged 1/2 npt(f) port at the left of the pump outlet. Make sure the gauge is correctly rated for the operating pressure.

Fluid Filters

Install two fluid filters (P) with line isolation valves (Q) on each side. This allows the system to be used while cleaning a filter.

Installation

Mounting the Pump

Secure the pump, **without the motor**, in the pump standpipe (V), using the bolts provided.

Be sure the pump inlet and the plumbing to the mix tanks are at the same level. Install the necessary plumbing, using shims as necessary. Then bolt the pump standpipe and the tanks securely to the floor.

⚠ CAUTION

Do not flush the pump with any acid, caustic or abrasive flush solution (line stripper) of any type. The pump is designed to circulate automotive paint coatings only.

After All Lines Are Installed

Flush all lines with a compatible solvent and blow out with air. Then clean the elements of the filters (P).

Installing the Motor

Remove the protective cover and the shipping dowel from the pump base (31). Remove the motor coupler (29).

When wiring the motor, be sure the shaft rotates in the direction shown on the pump base and in Fig. 2.

Place the motor coupler (29) on the motor shaft (A), pushing it up, well beyond the end of the shaft. Lightly snug the setscrew (B).

Lower the motor onto the pump base, making sure the motor locating flange seats properly on the pump base.

Loosen the motor coupler setscrew (B). Pull the coupler (29) down to engage with the pump coupler (58) and coupling insert (6).

Adjust the motor coupler to 0.094 in. (2.39 mm) clearance. See Fig. 2. Tighten the pump coupler setscrew.

⚠ CAUTION

1. Before operating the pump, turn the motor coupler by hand to be sure the shaft rotates freely in the correct direction. Then recheck the 0.094 in. (2.39 mm) coupler clearance.
2. The pump is factory-set to deliver maximum outlet pressure. Do not tamper with this adjustment as it could cause damage to the impellers and bowls and void the warranty.
3. Never leave any contaminants, nuts, bolts, rags, etc., in the fluid tank or supply lines as they could seriously damage the impellers or bowls.

- 1 Outlet Pressure Gauge
- 2 Direction of Rotation for Motor

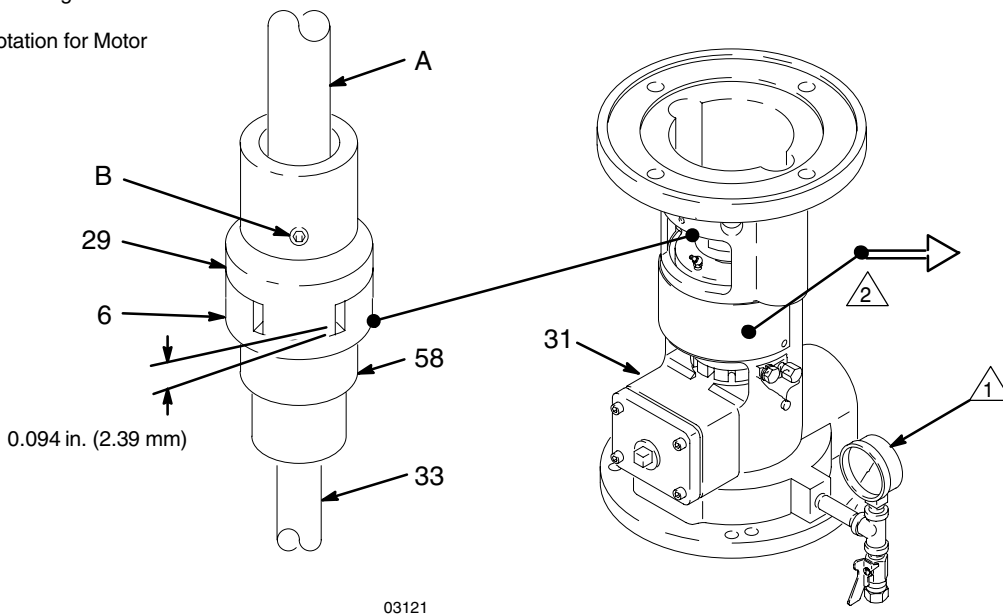

Fig. 2

Operation

CAUTION

The pump is designed for continuous operation. Regular shutdown at night or on weekends may cause premature bearing wear and invalidate the warranty.

Do not let the pump run dry. Operating the pump for more than 10 seconds without fluid circulating through it will overheat the pump and damage it.

Flushing and Priming System

(See the *Typical Installation and Fig. 2.*)

The procedure given here is for a stand-mounted pump, two mix tank system as shown in the **Typical Installation** on page 4. Some specific instructions may not apply to other systems; consult your plant's flushing procedures.

Flushing is important; it cleans all equipment and lines of impurities. Following these instructions will help assure satisfactory operation with quality control.

CAUTION

1. Be sure the motor rotates in the correct direction and the drive coupler clearance is set at 0.094 in. (2.39 mm). See Fig. 2.
2. If the motor labors or the pump does not run smoothly, check the motor for high amp draw and check the thrust bearing for overheating. The normal operating temperature is from 120° to 150° F (49° to 65° C). If the temperature is higher than 150° F (65° C), consult a qualified Graco representative after a repair check of the drive coupler clearance.
3. Be sure the circulating lines are flushed and primed with fluid as instructed below. Do not flush the pump with any acid, caustic or abrasive flush solution (line stripper) of any type. The pump is designed to circulate automotive paint coatings only.

1. Preparing to flush the inside of the mix tanks
 - a. Close the outlet valves (W) of both tanks.
 - b. Pour about 100 gallons (380 liters) of the appropriate solvent into each tank.
 - c. Open the outlet (W) and return valves (K) on one tank only.

2. Starting the pump
(Always use this procedure to start the pump)
 - a. Close the isolation valves (Q) on one filter.
 - b. Use the valve (Q) in front of the other filter to control the pump flow to 50 psi (3.5 bar) until the lines are full. Then completely open the valve.
 - c. Run the pump for several minutes, and then shut off the pump.
 - d. Recheck the drive coupler for 0.094 in. (2.39 mm) clearance.

CAUTION

The pump coupler and bearing could move up during shipment and then, when the pump is operated, it could move down, leaving too much clearance. This could damage both the coupler insert and the coupler.

3. Checking the system for leaks
 - a. Restart the pump and check the entire system for leaks.
 - b. Tighten leaking joints as necessary.
 - c. Periodically check for leaks during flushing.
4. Continue flushing
 - a. Continue circulating the solvent, changing the solvent as needed until the system is thoroughly flushed.
 - b. When the system is clean, stop the pump.
 - c. Drain all filtered residue from the filters (P).
 - d. Reconnect the return line (E) to the back pressure valve (F).

Operation

- e. Close the outlet (W) and return valves (K) for the tank being used and open the outlet and return valves for the other tank.
 - f. Start the pump and circulate the solvent for at least one hour.
 - g. While circulating, open the spray gun at each drop and flush the hoses with about one gallon (4 liters) of solvent.
5. When flushing is complete
- a. Stop the pump and drain all solvent from the tanks and lines.
 - b. Open the filter drain valves (R) to flush out all filtered residue.
 - c. Thoroughly blow out the entire system with clean, dry compressed air, or nitrogen, to remove all solvent from the system.
6. Pumping paint
- a. Fill a tank with paint and start the agitator (C).
 - b. Start the pump.
 - c. Use the filter isolation valve (Q) to control the pump flow to 50 psi (3.5 bar) until the lines are full, and then open the valve completely.
 - d. Circulate the paint until all air is removed from the fluid lines.
 - e. While the paint is circulating, check and adjust the viscosity as necessary.
7. Filling standby tank
- a. Fill the other mix tank (*standby tank*) with paint and start the agitator.
 - b. Leave the agitator running so that paint in the standby tank will be ready for use when needed.
 - c. To keep air out of the system, always switch to the standby tank before the paint supply in the tank you have been using is completely exhausted.

8. Flushing paint from system

Consult the paint supplier for a compatible solvent for flushing paint from the system. Water reducible paints should use de-ionized water and a solvent which will keep resin in the solution. If water reducible paint has a 20% solvent content, the flush media should also contain approximately 20% solvent.

CAUTION

Do not flush the pump with any acid, caustic or abrasive flush solution (line stripper) of any type. The pump is designed to circulate automotive paint coatings only.

CAUTION

De-ionized (D.I.) water is an aggressive, corrosive material. It can be used on the waterborne versions of the Imperial Pumps. Exposure of all other Imperial Pumps to D.I. water should be minimized, and the D.I. water should be flushed from the pump with a non-corrosive material such as alcohol.

Adjusting System Pressure

Use the back pressure valve (F) to adjust the system pressure.

Determine the line pressure required. Then, with paint circulating in the line loop only, set the back pressure valve so that the pressure at the last spray gun is 10 psi (0.7 bar) greater than needed.

Refer to the **Typical Installation** on page 4 and the separate back pressure valve instructions.

CAUTION

The pump is set at the factory to deliver the maximum volume and outlet pressure. The pressure cannot be increased by any adjustment of the pump. Refer to **Pump Thrust Bearing and Seal Replacement**, page 12, for proper adjustments.

Lubrication

Lubricate the thrust bearing once a month if the pump is operating continuously. To lubricate the bearing, pump one or two shots (about 0.1 oz/2.8 grams) of Chevron SRI/No. 2 NLGI grade grease through the fitting on the top of the seal retainer. A 14 oz. tube of this grease is supplied with the pump. See Fig. 3.

NOTE: Do not lubricate the bearing when you first receive the pump as it is factory greased.

⚠ CAUTION
Use only Chevron SRI/No. 2 NLGI grade grease to help prevent bearing overheating and premature bearing failure. This green or brown-colored grease is used for the factory pack and must not be mixed with any other type of grease. The use of any other type of grease will void the Graco Warranty.

⚠ CAUTION
Do not over grease the bearing, which may cause the bearing to overheat. Remove any excess grease after lubricating.

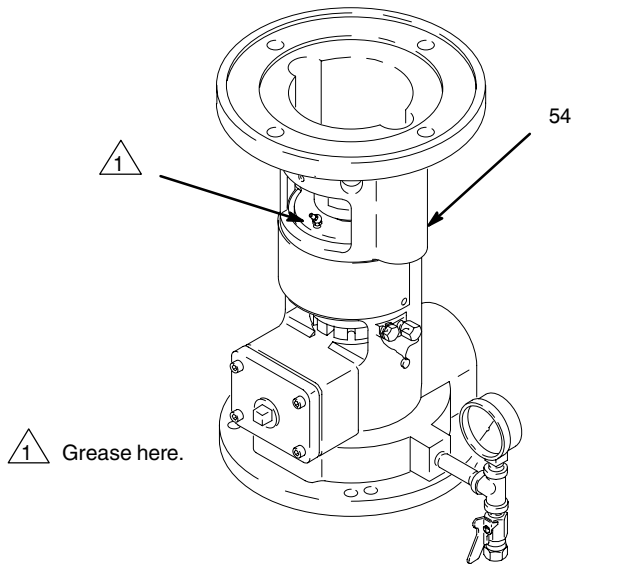

Fig. 3

03122

3122B

Thrust Bearing Temperature Monitoring

The 3/8" npt plug (54) can be removed from the pump base to install a temperature sensor to monitor thrust bearing temperatures. This sensor can be purchased from an appropriate outside supplier

Preventive Maintenance

Thrust Bearing. Once a month, lubricate the thrust bearing if pump is run continuously. Refer to thrust bearing **Lubrication** instructions on this page. It is recommended that the Imperial pump thrust bearing assembly be replaced at least once a year.

Pump Pressure, Flow, and Temperature. Once a month, check the static discharge pressure, flow rate of the pump, thrust bearing temperature, and coupler clearance. Record them.

NOTE: If the operating temperature exceeds 150° F (65° C) and normal maintenance, troubleshooting, and service fails to reduce temperature, contact a qualified Graco representative.

⚠ CAUTION
Blockage of the overflow tube and overflow chamber on pump base will cause leakage through the shaft seal and adjustment nut opening.

Troubleshooting

⚠ CAUTION

When checking the pump pressure, do not leave the check valve (J) or isolation valves (Q) closed for more than 10 seconds while the pump is operating to avoid overheating the pump and damaging the seals and bearings.

NOTE: Graco offers a rebuild program on all Imperial and Crown Imperial pumps. Contact your local sales representative for details.

⚠ WARNING

Before removing the pump for repair, shut off the electric power, **relieve the pressure**, and drain the pump by opening the drain valve at the pump base. This will help reduce the risk of serious injury from electric shock, moving parts, or splashing fluid in the eyes.

Problem	Cause	Solution
Pump won't run.	1. Electric power out.	1. Check fuses; clean terminals and connections.
	2. Fuses blown.	2. Check coupler clearance, replace fuses, repair pump (call Graco Detroit, see back page).
	3. Motor inoperative.	3. Repair or replace motor.
Pump runs but pressure drops slightly.	1. Clogged pump intake.	1. Remove and clean.
	2. Increased flow rate.	2. Adjust back pressure valve.
	3. Parts worn or damaged.	3. Repair pump.
	4. Air entrained in fluid.	4. *Purge air. See Startup Procedure on page 7.
Pump runs but pressure very low or unsteady.	1. Clogged pump inlet.	1. *Clean.
	2. Air entrained in fluid.	2. *Purge air. See Startup Procedure on page 7.
	3. Problem with electric motor.	3. Check motor for proper rotation. Check that RPM of motor is at least 3750 under load.

TROUBLESHOOTING CHART IS CONTINUED ON PAGE 11.

* Before removing the pump for cleaning, close the check valve (J) or line isolation valves (Q) and note the maximum pump pressure; the pressure should be steady. **Do not** leave valves closed for more than 10 seconds.

If pressure variations or pulsations are noted, the problem could be 1.) a clogged intake, 2.) too low a fluid level in the tanks, or 3.) restricted plumbing.

Correct the clogged condition to obtain steady pressure.

Low pressure can also be caused by air entrainment in water reducible fluids. All return lines in tanks with water reducible fluid must be routed to the bottom of the tank.

Be careful to avoid allowing deteriorated pieces of bag filters into the pump which can result in serious damage to the pump.

Troubleshooting

Problem	Cause	Solution
Fluid leaking.	1. Screws or fittings loose.	1. Tighten.
	2. Parts worn or damaged.	2. Repair pump.
	3. Clogged bypass drain.	3. Drain.
Leakage at shaft seal (41). (Leakage through the shaft seal/ adjustment nut opening.)	1. Fluid viscosity is too light (especially if using solvent or other flushing material).	1. Seal is designed for heavier viscosity fluid, such as paint. Problem should clear up after flushing is completed.
Noisy pump.	1. Improper coupler clearance.	1. Ensure 0.094 in. (2.39 mm) clearance. See Fig. 2, page 6.
	2. Motor not seating properly to pump housing.	2. Loosen motor mount nuts, clean flange and rotate motor to seat properly; check seal for damage.
	3. Lack of grease in main thrust bearing.	3. See Lubrication on page 9; check for worn shaft bearings.
Coupler insert (6) wears out prematurely.	Motor not seating properly to pump housing.	Loosen motor mount nuts, clean flange and rotate motor to seat properly; check seal for damage.

Service

⚠ CAUTION

To avoid costly damage to the pump, follow this service procedure carefully. Do not attempt to repair anything that is not mentioned in this service section.

Before you start

Special tools needed for repairing the pump are mentioned in the text and described in the **Accessories** section on page 26. Be sure you have all the necessary tools and repair parts on hand.

Pump Thrust Bearing and Seal Replacement

NOTE: It is not necessary to remove the pump from the standpipe. However, if you are also repairing the lower pump, you can install the shaft holding tool and move the pump to the repair stand at this time. Use the tool indicated in Fig. 4.

NOTE: Replace the pump thrust bearing (A) assembly at least once a year. Replace the assembly if the pump housing temperature goes over 150°F (53°C), which is the first sign of bearing failure.

Disassembly

(Refer to Fig. 5, except where indicated)

1. Shut off the power to the pump. Close the check valve (J) and/or the line isolation valves (Q). Remove the motor. Refer to **Installing the Motor** on page 6.
2. Remove the slinger chamber screws, cover and gasket (3, 21, 20). Inspect the chamber opening and clean out any residue.
3. Remove the retainer plate (58c) and rubber coupling insert (6) from the pump coupling assembly (58). Loosen the slinger (40) setscrew.
4. Hold the pump coupler (58) and screw the shaft nut (28) off the shaft (33), using a socket wrench.
5. Remove the screws, washers and springs (10, 11, 25) and lift out the coupling assembly (58).
6. Remove the bearing support (22) and key (58b) from the shaft (33).
7. Remove the adjusting nut lock screw and plug (19, 27). Then remove the adjusting nut (35).

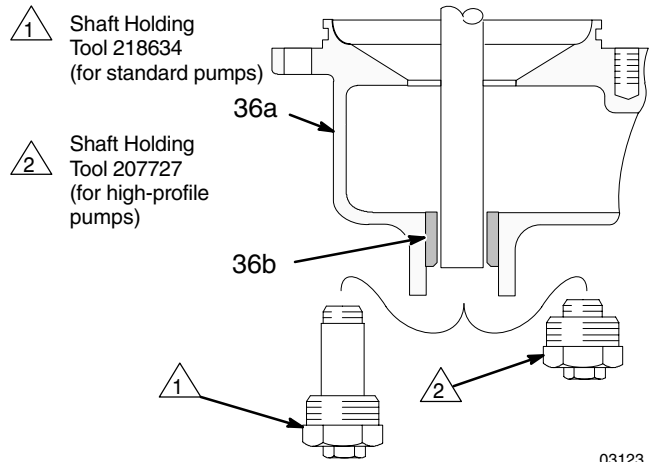

03123

Fig. 4

8. Remove the three screws (13) and shaft seal assembly (41).

NOTE: To service the lower pump section, refer to page 15. Otherwise, continue with Step 9.

9. If the pump is mounted in a repair stand, install the shaft holding tool. See Fig. 4.
10. Install the shaft seal assembly (41) with the three screws (13).
11. Replace the shaft seal (8) in the adjusting nut (35). Install the adjusting nut, engaging just one thread in the pump base (31).
12. Position the bearing support (22) on the adjusting nut (35) so its pin (P) and the slot in the support align.
13. Screw the adjusting nut (35) down just until the bearing support (22) bottoms out on the housing. Turn the nut back 1 to 1-1/2 turns to engage bearing support.
14. Slide the coupling assembly (58) over the shaft (33).
15. Align the keyway and insert the key (58b) between the coupling assembly and shaft.
16. Use the special tool, 178779, to check the shaft location dimension. Place the tool on the face of the coupler (58), between the coupler tabs as shown in the detail of Fig. 6. The tabbed portion of the tool should touch the top of the shaft (33). Screw the adjusting nut (35) up until you attain the 0.25 in. (6.3 mm) dimension.
17. Install the shaft nut (28) using a socket wrench and bottom it on the coupling assembly (58).
18. Align the hex of the nut retainer plate (58c) with the shaft nut (28) and secure the lockwire (58d).

Service

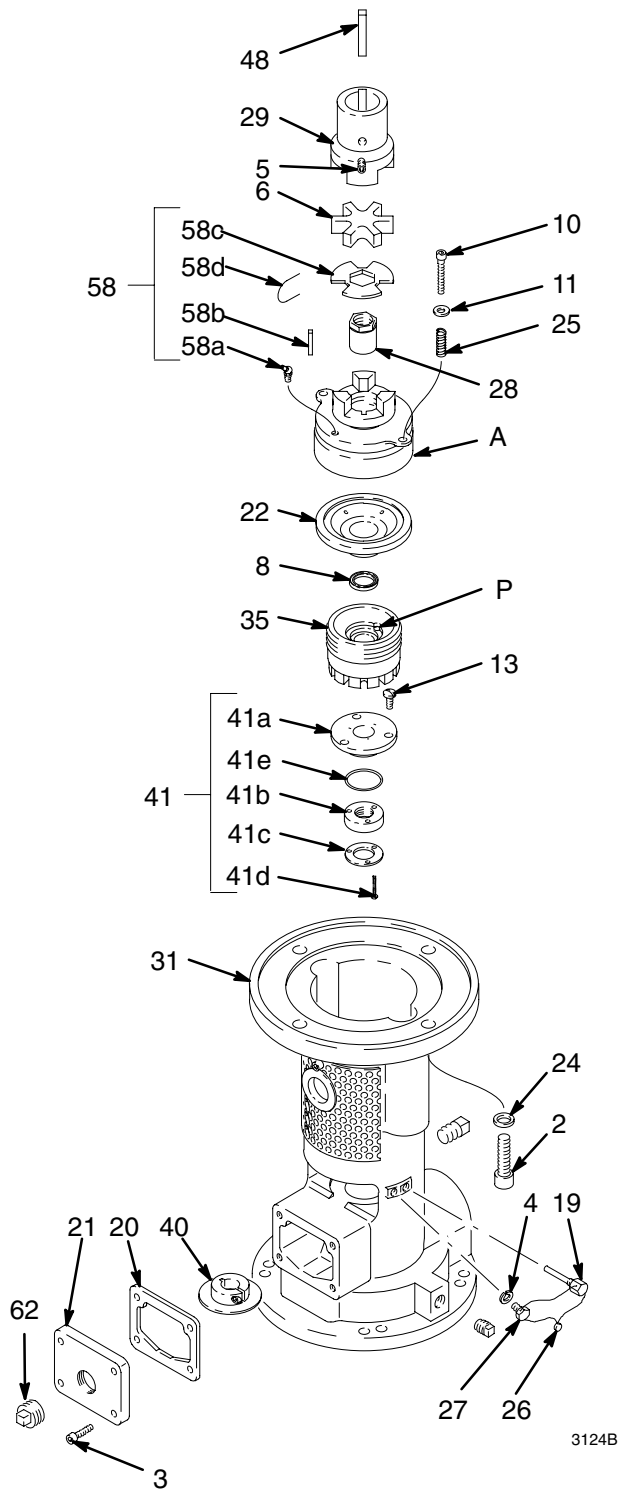

Fig. 5

19. Install the two hold-down screws, washers, and springs (10, 11, 25). Bottom the screws and check the vertical travel of the retainer (A) against the spring. If the shaft nut (28) and coupling housing (58) are properly installed, the retainer should lift 0.12 to 0.19 in. (3.2 to 3.8 mm) before the springs are solidly compressed.
20. **If the pump is mounted in an assembly stand,** loosen the shaft holding tool. See Fig. 4.

Turn the bearing adjusting nut (35) two and a half notches to the right to raise the impellers off the bowls. Now turn the pump coupler (58) to be sure the shaft (33) rotates freely. Check to see that the slinger (40) is located approximately in the center of the slinger chamber. See Fig. 6.

If the pump is not mounted in an assembly stand, turn the bearing adjusting nut (35) up until the shaft (only) rotates freely. Then raise it another two and a half notches to raise the impellers off the bowls. See Fig. 6.

21. Install the lock screw (19) through the pump base and into the hole in the adjusting nut (35) without forcing it. Install the plug (27). If necessary, turn the adjusting nut a little, in the same direction as pump rotation, until the plug goes in easily. Tighten the plug securely and attach the lock wire (26) and crimp. See Figs. 5 and 6.
22. Install the gasket, slinger chamber cover, and screws (20, 21, 3) on the front of the pump base.
23. Install the rubber coupling insert (6) and remount the motor. Refer to Fig. 2, page 6.
24. Remove the shaft holding tool, if installed. Install the plug (49) and gasket (50) (see the parts drawing). Start the pump. Use the filter isolation valves (Q) to control the pump flow to 50 psi (3.5 bar) until the lines are full, and then completely open the valves. Circulate the paint until all air is removed from the fluid lines. Close the check valve (J) or isolation valves (Q). Note the maximum pump pressure. The pressure should be steady. If variations or pulsations are noted, the inlet flow to the pump is restricted, due to either a clogged screen or restricted plumbing. Correct the clogged condition.

CAUTION

When checking the pump pressure, **do not** leave the check valve (J) or isolation valves (Q) closed for more than 10 seconds while the pump is operating to avoid overheating the pump and damaging the seals and bearings.

Service

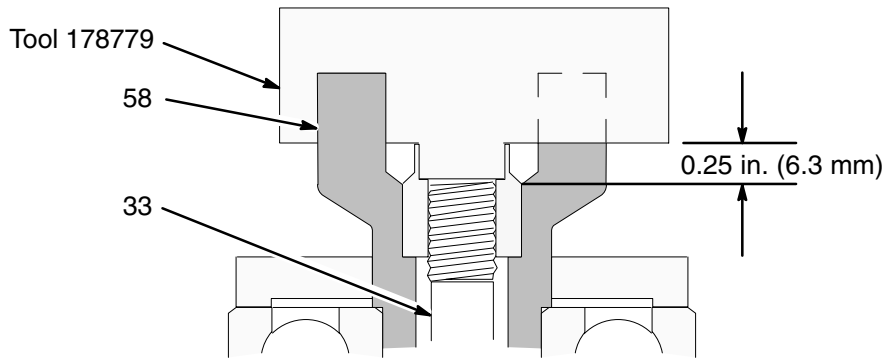

03125

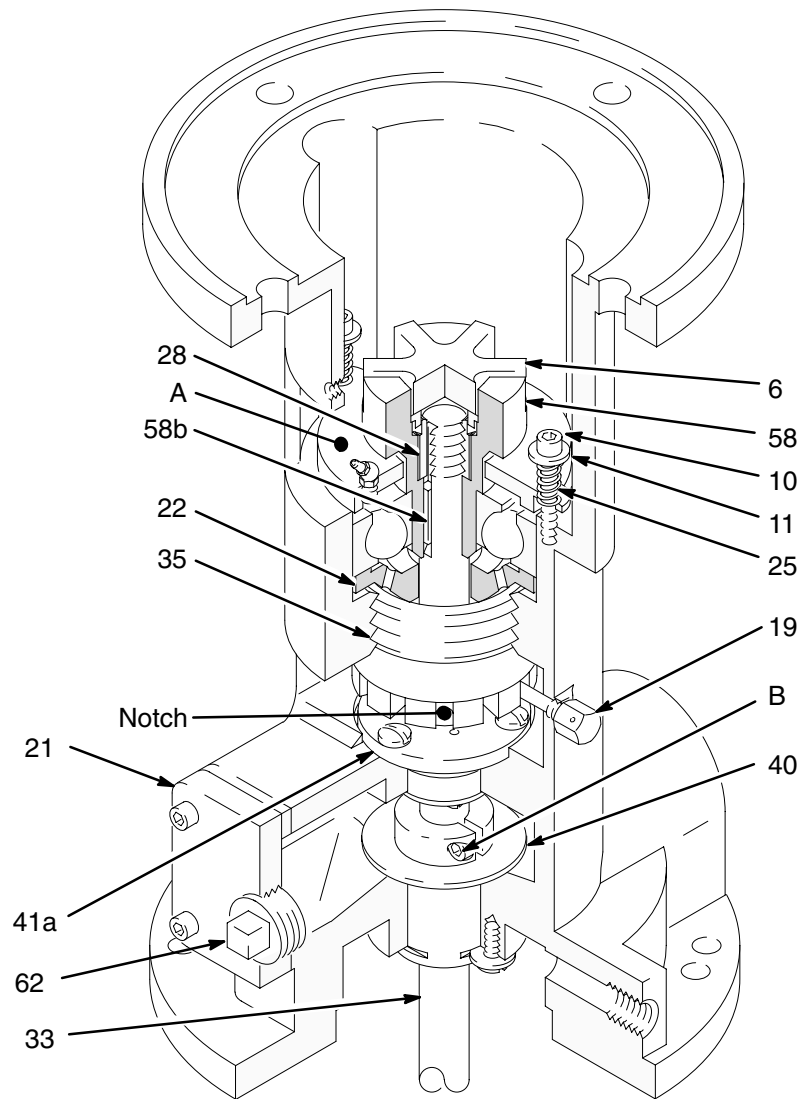

3126B

Fig. 6

Service

25. Shut the pump off and recheck the coupler clearance; adjust if necessary to 0.094 in. (2.39 mm). See Fig. 7.
26. Remove the seal chamber cover (21) and check to be sure the slinger (40) is in the middle of the chamber. See Fig. 6. If necessary, loosen the setscrew (B) with a 0.19 in. hex key wrench to readjust the slinger. Reinstall the cover, gasket and screws (3, 20, 21).

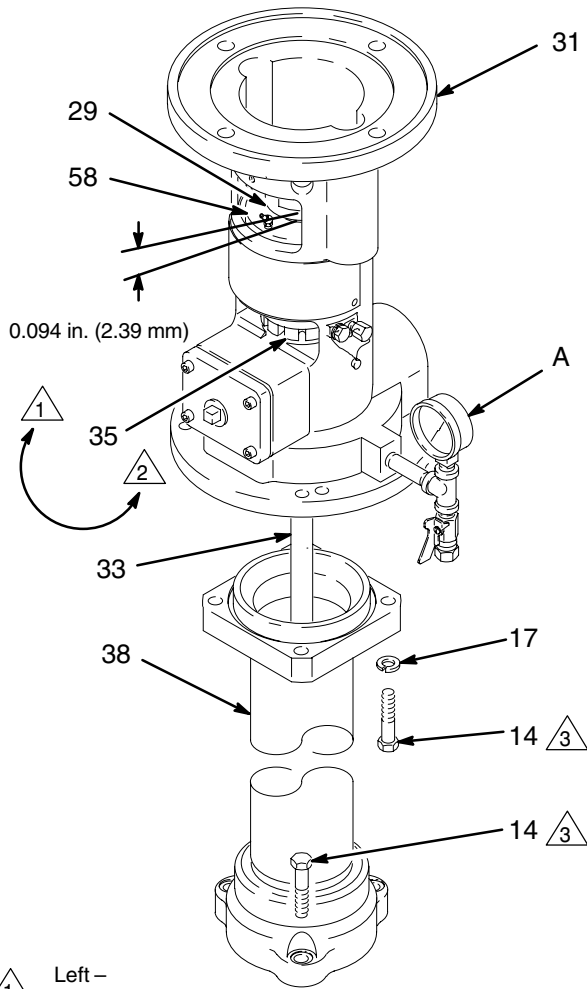

- 1 Left – Increase Pressure
- 2 Right – Decrease Pressure
- 3 Torque to 30–35 ft-lb (27–47 N.m)

03127B

Fig. 7

Repairing Shaft Bearings, Impellers, and Seals

Disassembly

NOTE: Remove the pump from the regular stand.

1. Support the pump in a vertical position on the accessory stand 953912, which must be bolted to the floor for stability. Lock the pump in place. Refer to Fig. 8.
2. Follow the disassembly procedure, Steps 1–8, on page 12.
3. Remove the capscrews (14) at the top flange of the riser tube (38). See Fig. 7.
4. Lift the pump base (31) straight up, off the shaft (33). Avoid bending the shaft by unequal pulling with a hoist or pry bars. Remove the capscrews (14) at the bottom of the tube and remove the riser tube (38). See Fig. 7.

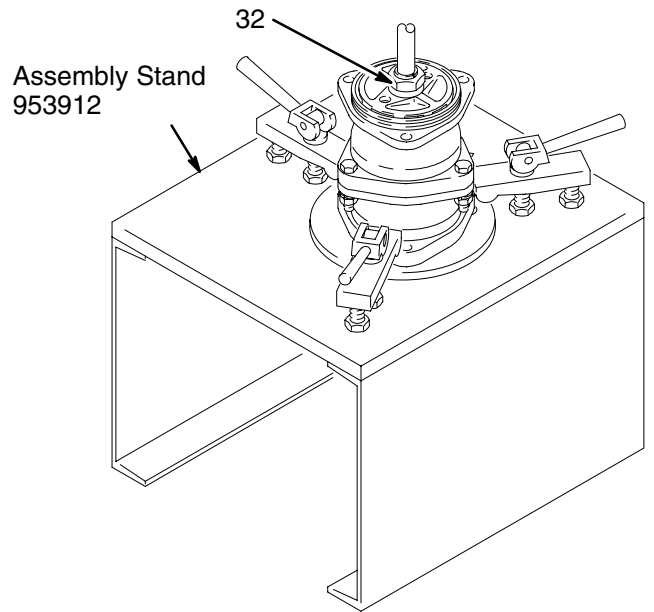

03128

Fig. 8

Service

5. Disassemble the impeller bowls, working from the top down.

a. Hold the first impeller with a spanner wrench 616637 and use a close fitting wrench to loosen the impeller nut (32) 1-1/2 turns. See Fig. 8.

b. Place a 3/4 in. (19 mm) ID soft-steel, protecting bushing, with a smooth turned end, on top of the hex nut. Use a sharp downward blow with a 1 foot (300 mm) length of pipe or tube over the shaft (33) to loosen the collet (18). See Fig. 9.

c. Remove the collet (18) and impeller (30). Do not pry the impeller.

d. Remove all of the impeller bowl assemblies in this way.

6. Inspect the shaft (33) for scoring or wear and replace it, if needed. Check all bowls and impellers for wear or damage and replace as needed. Install new o-rings (9) on all impeller bowls (37b) and the intake bowl (36a), then lubricate the o-rings in place. Be sure the impeller nuts (32) rotate freely on the collets.

7. To replace the bearings:

a. Use the short-nippled end of tool 177219 to press out the bearings (37a) from all bowls (37b) and the intake bowl (36a). See Fig. 10.

b. Use the long-nippled end of the tool to press new bearings (36b, 37a) into the bowls. This tool maintains the required 0.06 in. (1.6 mm) dimensions of the impeller bowls as shown in Fig. 10.

c. Thread the shaft holding tool into the bottom of the intake bowl as shown in Fig. 11.

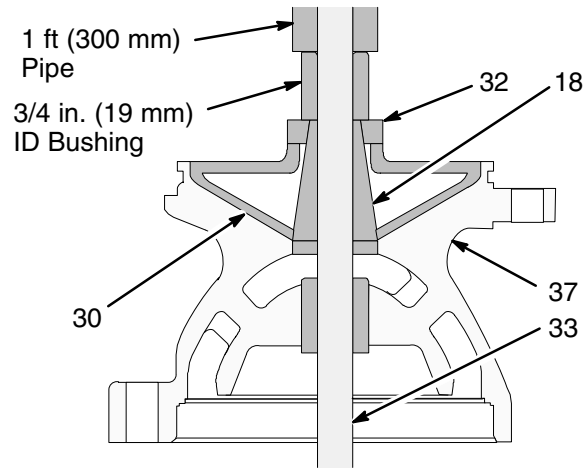

03129

Fig. 9

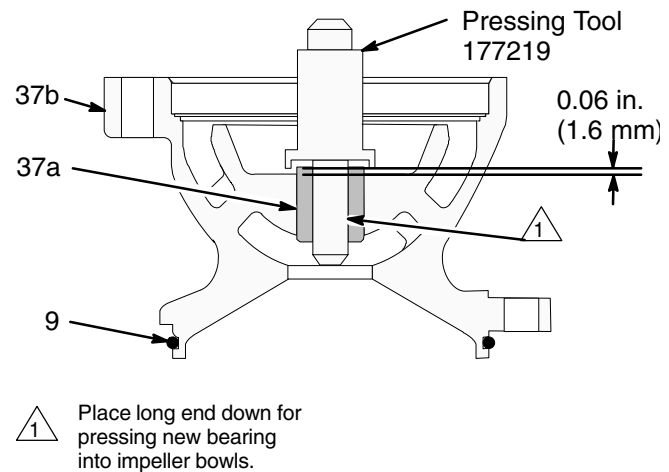

03130

Fig. 10

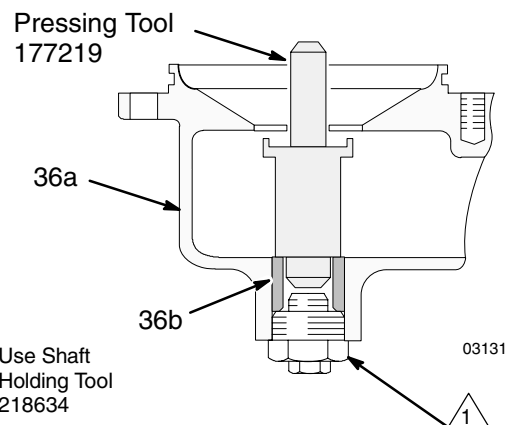

Fig. 11

Procedure is continued on page 17.

Service

- d. Use the short-nippled end of tool 177219 to press the new bearing into the intake bowl until it bottoms against the shaft holding tool. Refer to Fig. 10.
- e. Check the bearings for concentricity. Place the checking fixture 177218 on the bowl as shown in Fig. 12. Drop the long end of the checking tool 177217 into the center hole of the fixture. The tool should turn freely without binding. If the tool binds, the bearings must be replaced.

Reassembly

8. Slide the shaft (33) into the bearing in the intake bowl (36a) and lock it in place with the shaft holding tool. See Fig. 13.
9. Clamp the intake bowl in a vise.
10. Assemble the first impeller (30), collet (18) and impeller nut (32) onto the shaft (33). See Fig. 14. Push downward on the impeller and hold it with the spanner wrench, 616637, while tightening the impeller nut to 130–150 ft-lb (175 – 205 N•m). Refer to Fig. 15.
11. Install the first impeller bowl (37) and bolt it to the intake bowl (36a) with screws (14) and lock-washers (17) and nuts (15). See Fig. 14.

NOTE: Each impeller must be bolted down tightly into the bowl while tightening the impeller. This assures contact with the machined face of the bowl, which will ensure maximum pump performance.

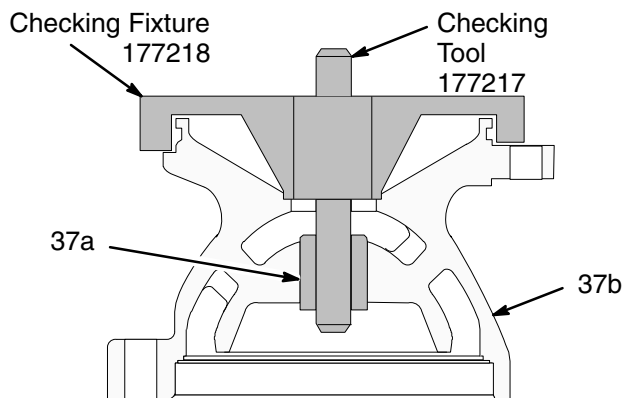

03132

Fig. 12

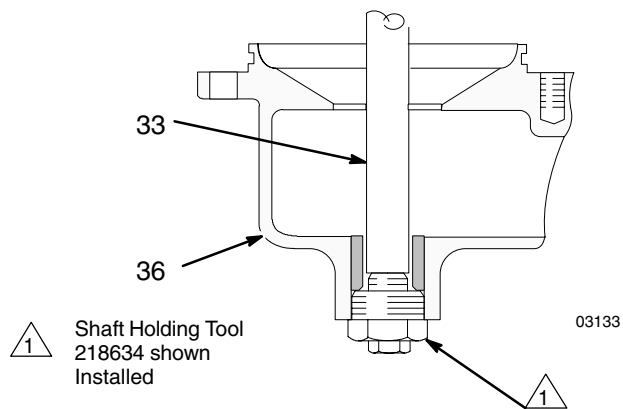
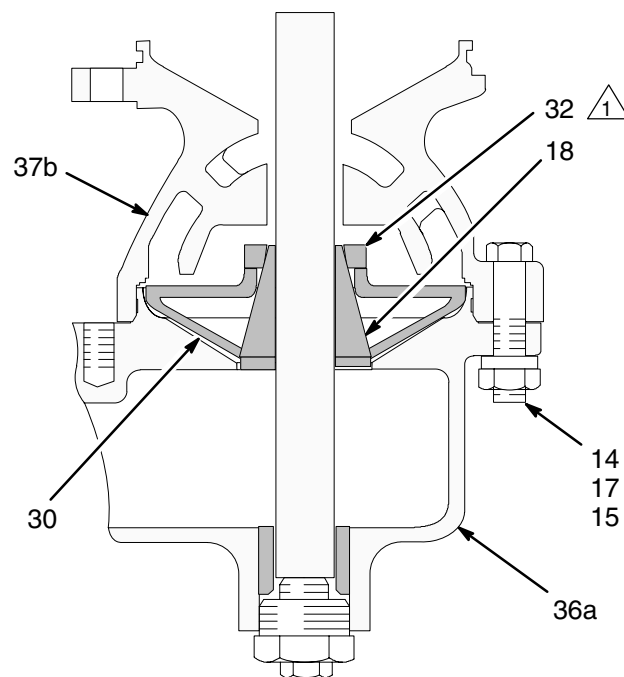

Fig. 13



1 Torque to 130–150 ft-lb (175–205 N.m)

03134

Fig. 14

Service

12. Remove the assembly from the vise and mount it in the assembly stand 953912. See Fig. 15.
13. Continue assembling the bowls and impellers as in Steps 10 and 11.
14. Install the riser tube (38) with the screws (14), lockwashers (17) and nuts (15). See Fig. 7.
15. To replace the bearing (39) in the pump base (31), remove the three screws and washers (7, 34), holding the bearing from below. Press the bearing out, using a 1.5 in. (38 mm) disc laid on the bearing and a 0.68 in. (17.3 mm) rod inserted from the top to push it out. See Fig. 16. This bearing has a medium-tight fit. Replace the bearing when replacing the impeller bearings.

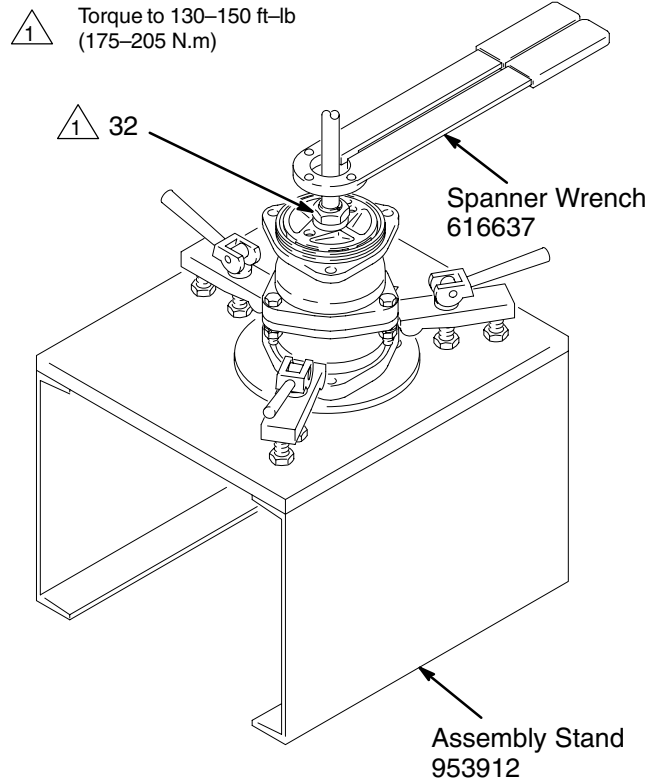

Fig. 15

03135

Assembling Lower Pump Section to Base

NOTE: Be sure the pump base (31) is clean, and that a new base bearing (39) has been installed.

1. Install the slinger (40) in the pump base with the flange down. Use a wooden dowel, just under 0.75 in. (19 mm) diameter, to align the slinger when assembling the pump base onto the shaft.
2. Carefully lower the base (31) over the shaft (33), passing the shaft through the bearing and slinger. Seat the base firmly on the riser tube (38). Install the four capscrews (14) and washers (17). Torque to 30–35 ft-lb (27–47 N•m). Refer to Fig. 7.
3. Adjust the slinger to the center of the seal chamber opening. Tighten the slinger setscrew (B). Refer to Fig. 6.
4. Continue assembling the pump as described in Steps 10 to 26 on pages 12 to 15.

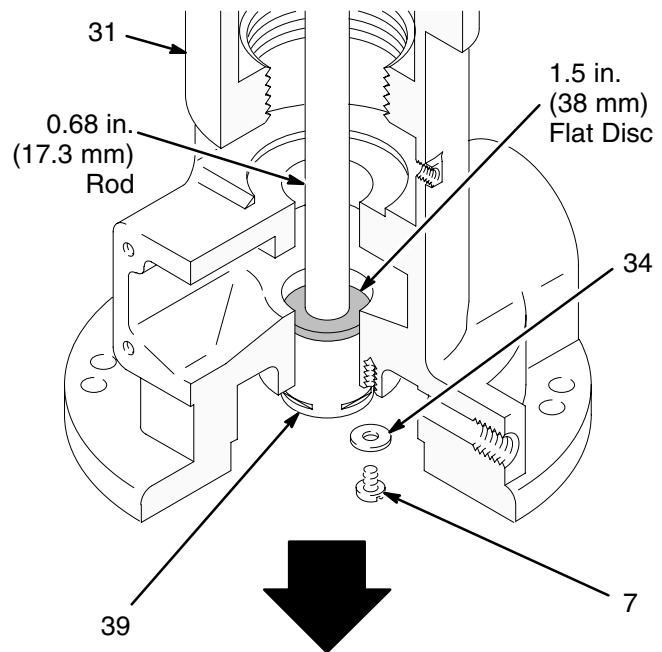
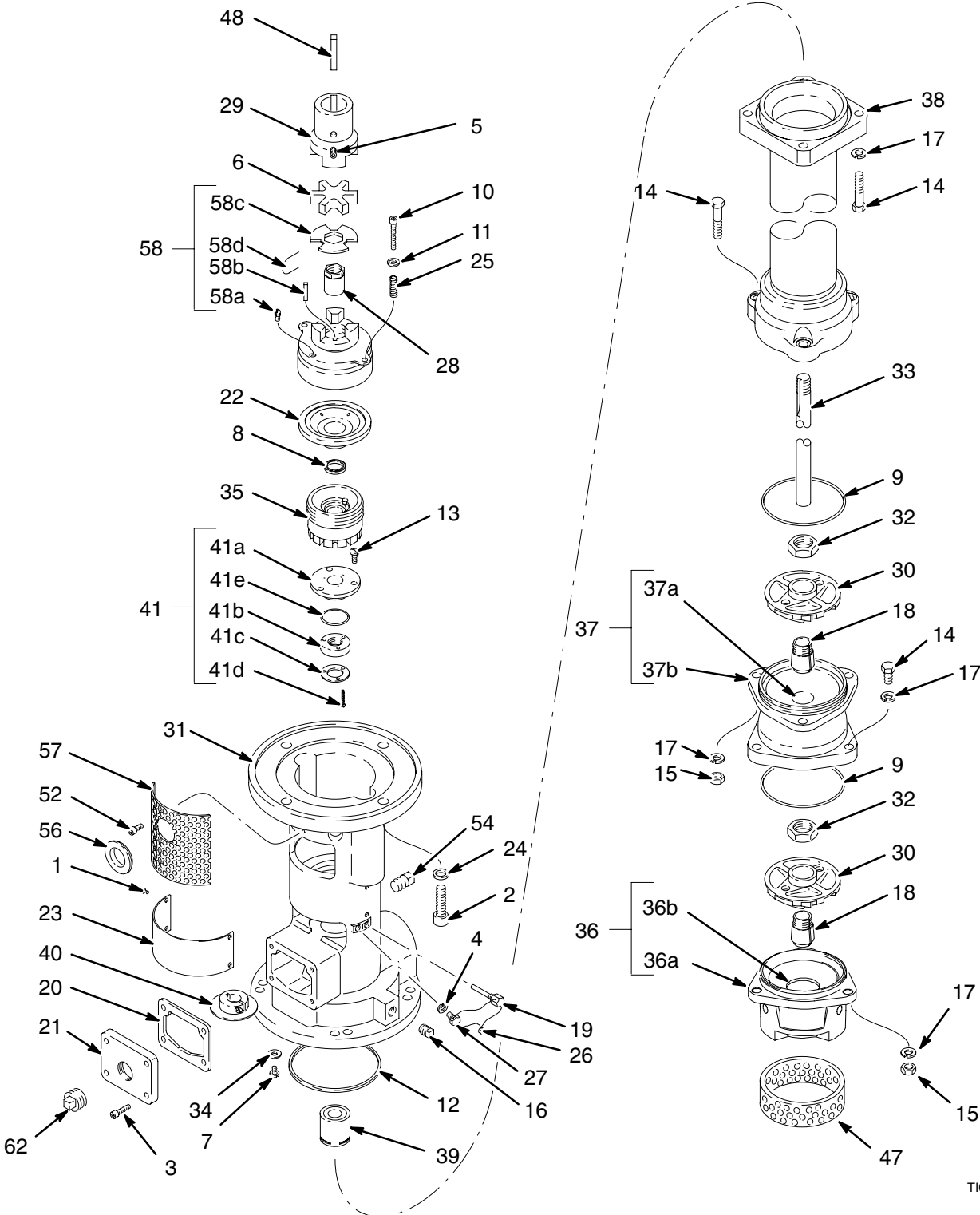

Fig. 16

03136

Parts

Corrosion Resistant, 60" Pump



T10570B

Parts

Corrosion Resistant 60" Pump

Model	Stages
223806	6
223807	7
223808	8
223809	9
223810	10
223811	11
223812	12
223813	13
223814	14

Ref No.	Part No.	Description	Qty	Ref No.	Part No.	Description	Qty
				24	168381	WASHER, .53" ID	4
				25	186111*	SPRING, compression	2
				26	104274	LOCK, wire	1
				27	171711	PLUG, special	1
				28	168500*	NUT, shaft	1
				29	170067	COUPLING, motor fits 1.38" (35 mm) motor shaft	1
					169445	fits 1.12" (28.4 mm) motor shaft	1
				30	170748*	IMPELLER, pump	1/Stage
				31	186096	BASE, pump	1
				32	170770*	NUT, impeller	1/Stage
				33	176879	SHAFT, impeller	1
				34	170772	WASHER, plain, 1/4"	3
				35	207769	NUT, adjusting	1
				36	215573	INTAKE BOWL ASSEMBLY <i>Includes item 36a and 37b</i>	1
1	100055	SCREW, type "u" self tap, no. 6 x 1/4"	4	36a	176878	. HOUSING, intake bowl	1
2	110343	CAPSCREW, hex hd, 1/2-13 x 1-3/4"	4	36b	176851	. BEARING, intake bowl	1
3	110787	CAPSCREW, sch, 1/4-28 unf-3a x .75"	4	37	218092	IMPELLER BOWL ASSEMBLY <i>Includes items 37a and 37b</i>	1
4	100214	LOCKWASHER, spring, 5/16"	1			6 to 11 Stage Pumps	10
5	100640	SCREW, cup pt slotted headless set, 5/16 x 3/8"	1			12 & 13 Stage Pumps	12
6	102211*	INSERT, coupling, rubber	1			14 Stage Pumps	14
7	110751	SCREW, mach, pnhd, 1/4-28 unf-2a x .375"	3	37a	176851	. BEARING, impeller bowl	1/bowl
8	102776*	SEAL, shaft	1	37b	179774	. HOUSING, impeller bowl	1/bowl
9	106524*	SEAL, o-ring, Viton®	1	38	218632	TUBE, riser, 24.5" (622 mm)	1
		6 to 11 Stage Pumps	12		220008	6 to 11 Stage Pumps	1
		12 & 13 Stage Pumps	14		220005	12 and 13 Stage Pumps	1
		14 Stage Pumps	16		218309	14 Stage Pumps	1
10	110753*	CAPSCREW, sch, 1/4-28 unf-3a x 1.625"	2	39	208846	BEARING, pump base	1
11	110755*	WASHER, plain, .281" ID	2	40	223605*	RING, slinger	1
12	102848*	PACKING, sq section	2	41		SHAFT SEAL ASSEMBLY <i>Includes items 41a-41e</i>	1
13	110752	SCREW, mach, pnhd, 1/4-28 unf-2a x .625"	3	41a	186215	. SUPPORT, seal	1
14	103776	SCREW, hex hd, 7/16-14 x 2"	38	41b	178697	. SEAL, shaft, PTFE	1
		6 to 11 Stage Pumps	44	41c	170762	. RETAINER, seal	1
		12 & 13 Stage Pumps	50	41d	107246	. SCREW, pan hd mach, no. 5-40 x 5/8"	3
		14 Stage Pumps	56	41e	102895*	. PACKING, o-ring, Viton®	1
15	103777	NUT, hex, 7/16"	30	47	177596	STRAINER, inlet	1
		6 to 11 Stage Pumps	36	48	107055	KEY, parallel 5/16", use with coupling 170067	1
		12 & 13 Stage Pumps	42		160906	1/4", use with coupling 169445	1
		14 Stage Pumps	1	52	110754	CAPSCREW, sch, 1/4-28 unf-3a x .5"	1
16	110786	PLUG, pipe, 1/4-18 npt	1	54	110762	PLUG, pipe, 3/8-18 npt	1
17	103780	LOCKWASHER, spring 7/16"	44	56	108027	GROMMET	1
		6 to 11 Stage Pumps	50	57	186349	GUARD	1
		12 & 13 Stage Pumps	56	58	223606	COUPLING ASSEMBLY <i>Includes replacement items 58a-58d</i>	1
		14 Stage Pumps	1	58a	100847	. FITTING, hydraulic, 1/4-28, 45°	1
18	186646*	COLLET, impeller	1/Stage	58b	168372	. KEY, 0.187" square x 1" long	1
19	168352*	SCREW, lock, adjusting nut	1	58c	166007*	. PLATE, retainer, shaft nut	1
20	186117*	GASKET, slinger	1	58d	068069*	. WIRE, lock	1
21	191401	COVER, slinger ring, 1" npt port	1	61	107411	GREASE, Chevron SRI Grease-2 14 oz.	1
22	168363	SUPPORT, bearing	1	62	113561	PLUG, 1 in., npt	1
23	186124	PLATE, instruction	1				

* Recommended spare parts to keep on hand.

Parts

Waterborne 60" Pump

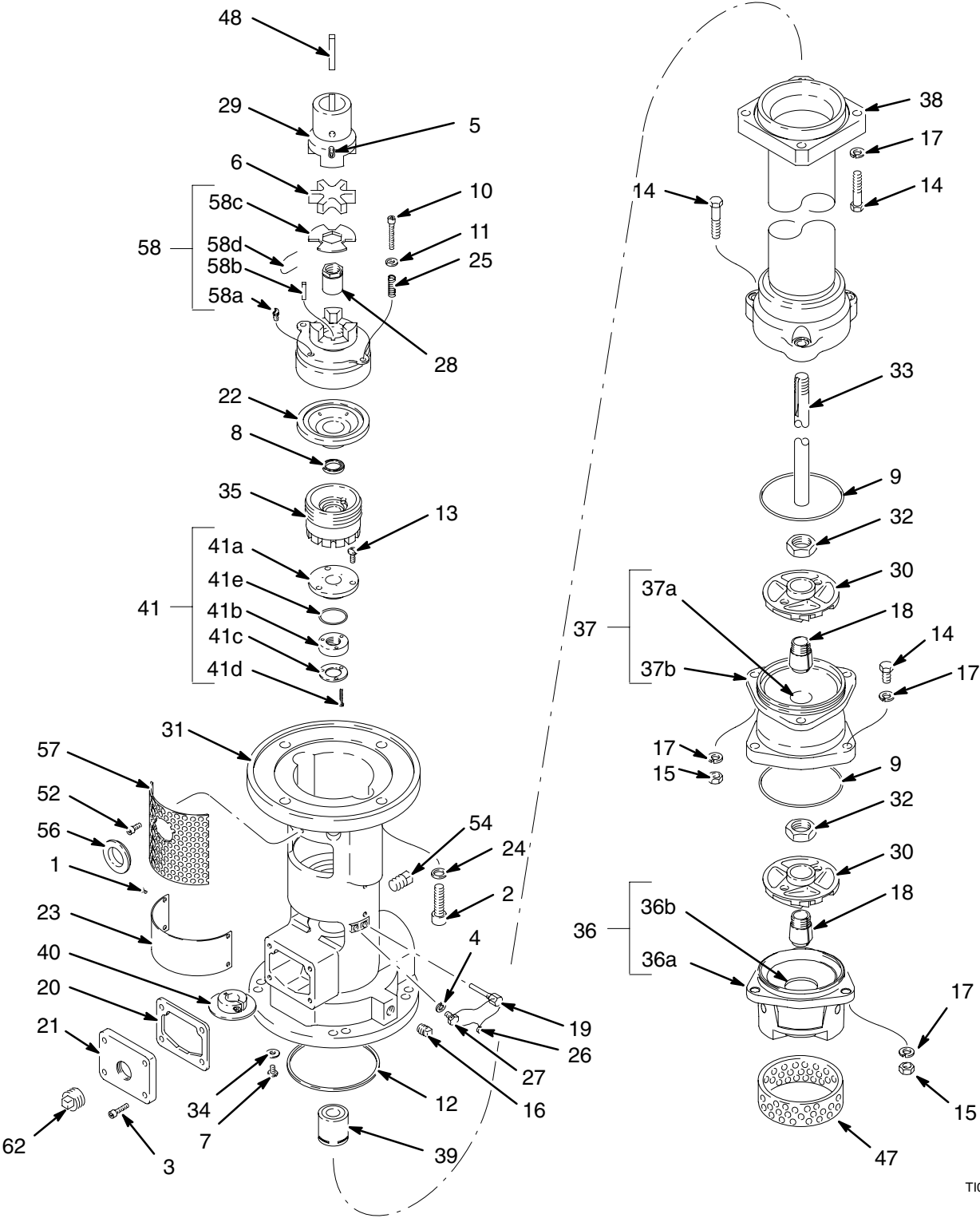

T10570B

Parts

Waterborne 60" Pump

Model	Stages
223706	6
223707	7
223708	8
223709	9
223710	10
223711	11
223712	12
223713	13
223714	14
237015	15

Ref

Ref No.	Part No.	Description	Qty
1	100055	SCREW, type "u" self tap, no. 6 x 1/4"	4
2	110343	CAPSCREW, hex hd, 1/2-13 x 1-3/4"	4
3	110787	CAPSCREW, sch, 1/4-28 unf-3a x .75"	4
4	100214	LOCKWASHER, spring, 5/16"	1
5	100640	SCREW, cup pt slotted headless set, 5/16 x 3/8"	1
6	102211*	INSERT, coupling, rubber	1
7	110751	SCREW, mach, pnhd, 1/4-28 unf-2a x .375"	3
8	102776*	SEAL, shaft	1
9	106524*	SEAL, o-ring, Viton®	1
		6 to 11 Stage Pumps	11
		12 Stage Pumps	12
		13 Stage Pumps	13
		14 Stage Pumps	14
10	110753*	CAPSCREW, sch, 1/4-28 unf-3a x 1.625"	2
11	110755*	WASHER, plain, .281" ID	2
12	102848*	PACKING, sq section	2
13	110752	SCREW, mach, pnhd, 1/4-28 unf-2a x .625"	3
14	103776	SCREW, hex hd, 7/16-14 x 2"	38
		6 to 11 Stage Pumps	44
		12 & 13 Stage Pumps	50
		14 Stage Pumps	50
15	103777	NUT, hex, 7/16"	30
		6 to 11 Stage Pumps	36
		12 & 13 Stage Pumps	42
		14 Stage Pumps	42
16	110786	PLUG, pipe, 1/4-18 npt	1
17	103780	LOCKWASHER, spring 7/16"	44
		6 to 11 Stage Pumps	50
		12 & 13 Stage Pumps	56
		14 Stage Pumps	56
18	186646*	COLLET, impeller	1/Stage
19	168352*	SCREW, lock, adjusting nut	1
20	186117*	GASKET, slinger	1
21	191401	COVER, slinger ring, 1" npt port	1
22	168363	SUPPORT, bearing	1
23	186124	PLATE, instruction	1
24	168381	WASHER, .53" ID	4
25	186111*	SPRING, compression	2
26	104274	LOCK, wire	1
27	171711	PLUG, special	1
28	168500*	NUT, shaft	1
29	170067	COUPLING, motor fits 1.38" (35 mm) motor shaft	1
	169445	fits 1.12" (28.4 mm) motor shaft	1
30	170748*	IMPELLER, pump	1/Stage
31	186266	BASE, pump	1
32	170770*	NUT, impeller	1/Stage
33	176879	SHAFT, impeller	1
34	170772	WASHER, plain, 1/4"	3
35	207769	NUT, adjusting	1
36	215573	INTAKE BOWL ASSEMBLY <i>Includes item 36a and 37b</i>	1
36a	176878	. HOUSING, intake bowl	1
36b	176851	. BEARING, intake bowl	1
37	218092	IMPELLER BOWL ASSEMBLY <i>Includes items 37a and 37b</i>	1
		6 to 11 Stage Pumps	10
		12 & 13 Stage Pumps	12
		14 Stage Pumps	14
37a	176851	. BEARING, impeller bowl	1/bowl
37b	179774	. HOUSING, impeller bowl	1/bowl
38	218632	TUBE, riser, 24.5" (622 mm)	1
	220008	6 to 11 Stage Pumps	1
	220005	12 and 13 Stage Pumps	1
	39	14 Stage Pumps	1
	218309	BEARING, pump base	1
	40	RING, slinger	1
	41	SHAFT SEAL ASSEMBLY <i>Includes items 41a-41e</i>	1
	41a	. SUPPORT, seal	1
	41b	. SEAL, shaft, PTFE	1
	41c	. RETAINER, seal	1
	41d	. SCREW, pan hd mach, no. 5-40 x 5/8"	3
	41e	. PACKING, o-ring, Viton®	1
	47	STRAINER, inlet	1
	48	KEY, parallel 5/16", use with coupling 170067	1
	107055	1/4", use with coupling 169445	1
	160906	CAPSCREW, sch, 1/4-28 unf-3a x .5"	1
	52	110754	1
	54	110762	1
	56	108027	1
	57	186349	1
	58	223606	1
		COUPLING ASSEMBLY <i>Includes replacement items 58a-58d</i>	1
	58a	100847	1
	58b	168372	1
	58c	166007*	1
	58d	068069*	1
	61	107411	1
	62	113561	1

* Recommended spare parts to keep on hand.

Dimensions

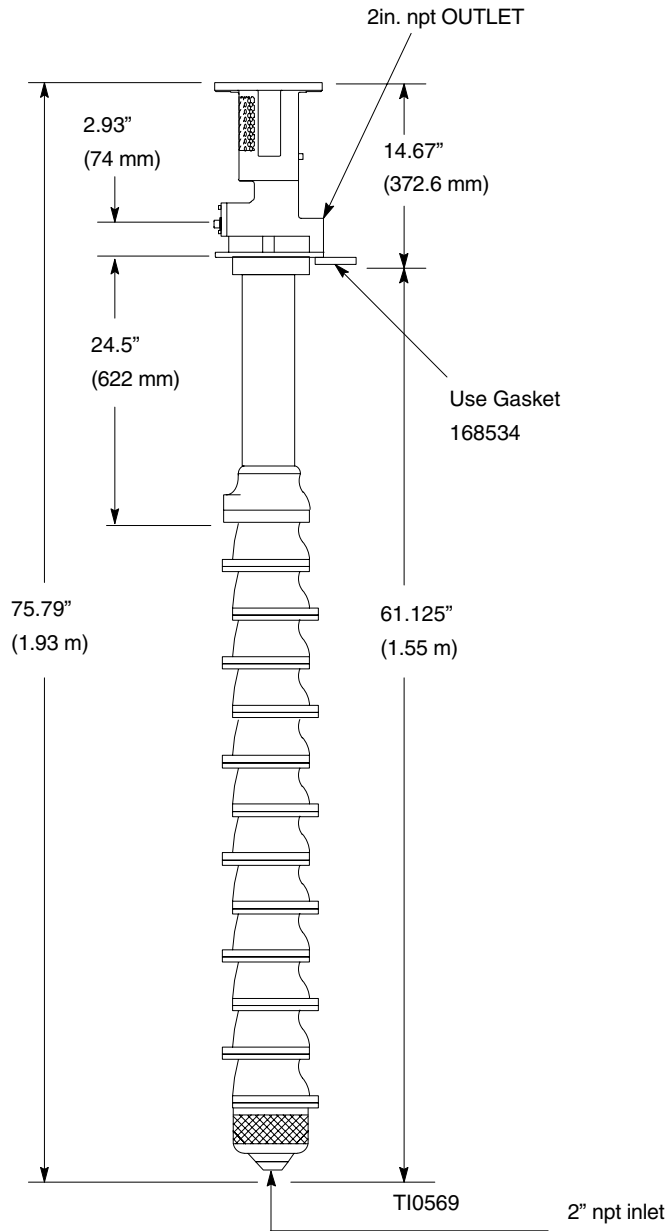

Pump	No. of Stages	Weight lb (kg)
223806 / 223706	6	205 (92)
223807 / 223707	7	207 (93)
223808 / 223708	8	208 (94)
223809 / 223709	9	210 (94)
223810 / 223710	10	211 (95)
223811 / 223711	11	213 (96)
223812 / 223712	12	224 (101)
223813 / 223713	13	225 (101)
223814 / 223714	14	235 (106)
237015	15	237 (106)

Accessories

Use Only Genuine Graco Parts and Accessories

⚠ WARNING

Be sure the valves, plumbing and accessories used in your system have a working pressure rating at least as high as the maximum working pressure rating of the pump.

SERVICE TOOLS

Shaft Holding Tool 218634

Shaft Adjusting Tool 178779

Required for setting coupler gap.

Checking Tool 177217

Check Fixture 177218

Used with Checking Tool 177217 to check concentricity of new bearings pressed into impeller bowls.

Pressing Tool 177219

Used for pressing new bearings into bowls to maintain proper clearance of bearings.

Spanner Wrench 616637

For holding impellers while torquing impeller nuts.

Chevron SRI Grease-2 107411

14 oz. Required for lubricating pump. One tube is included with new pumps.

Assembly Stand 953912

Must be used to assemble the pump in the proper upright position, maintaining alignment.

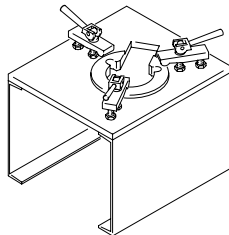

Back Pressure Valve 208997

180 psi (1.2 MPa, 12 bar) Controlled Working Pressure

200 psi (1.4 MPa, 14 bar) Maximum Working Pressure

Stainless Steel. 0.5 in. (12.7 mm) dia. orifice.

1-1/4 in. npt inlet and outlet.

Includes 200 psi (14 bar) pressure gauge.

High Capacity Bag Filters

300 psi (2.1 MPa, 21 bar) Maximum Working Pressure

Heavy-duty, large-area perforated filter bag baskets with 1/4 in. npt blowdown port on cover. Uses optional wire mesh liner for dual-stage filtration. Ask your distributor to show you Form No. 300081 for part number and ordering information.

Fluid Pressure Gauge and Pulsation Dampeners

300 psi (2.1 MPa, 21 bar) Maximum Working Pressure

1-1/4 in. npt inlet and outlet; inline.

Flow rating: 20 gpm (75 liters/min).

Calibrated at 100 centipoise, specific gravity 0.85.

208855 For use with corrosive fluids.

1/4 npt(m) inlet. 300 psi (21 bar)

Maximum Working Pressure

206171 For use with non-corrosive fluids.

1/4 npt(m) inlet. 200 psi (14 bar)

Maximum Working Pressure

Gasket 168534

Required for mounting pump on standpipe.

Accessories

Use Only Genuine Graco Parts and Accessories

Adapter Kit 213049

For 10 and 15 HP Electric Motors. Includes adapter plate, coupling, coupling insert, and screws and washers.

Electric U-Frame Motors

Motor	H.P.	Voltage	Rating
521470	3	230/460	Standard
521469	5	230/460	Standard
521468	7.5	230/460	Standard
521467	10	230/460	Standard
521466	15	230/460	Standard
521888	20	230/460	Standard
521455	7.5	600	Standard
51A649	3	CSA 575	Standard
51A650	5	CSA 575	Standard
51A651	7.5	CSA 575	Standard
51A652	10	CSA 575	Standard
51A653	15	CSA 575	Standard
51A654	20	CSA 575	Standard
516821	3	230/460	Premium
516732	5	230/460	Premium
516824	7.5	230/460	Premium
516825	10	230/460	Premium
516731	15	230/460	Premium
516827	20	230/460	Premium
51B297	3	CSA 575	Premium
51B298	5	CSA 575	Premium
51B299	7.5	CSA 575	Premium
51B300	10	CSA 575	Premium
51B301	15	CSA 575	Premium
51B302	20	CSA 575	Premium
114937	10	575	Inverter Duty
51B157	15	230/460	Inverter Duty
51B778	10	230/460	Inverter Duty
116228	10	380	Inverter Duty
51B673	7.5	380V/50Hz	Standard
51B674	10	380V/50Hz	Standard
51B675	15	380V/50Hz	Standard
51B676	20	380V/50Hz	Standard
51B677	7.5	380V/50Hz	Premium
51B678	10	380V/50Hz	Premium
51B679	15	380V/50Hz	Premium
51B680	20	380V/50Hz	Premium

Electric T-Frame Motors

Motor	H.P.	Voltage	Rating
521441	3	230/460	Standard
521429	5	230/460	Standard
51B296	7.5	230/460	Standard
516826	10	230/460	Standard
521456	15	230/460	Standard
521454	20	230/460	Standard
516822	3	230/460	Premium
516823	5	230/460	Premium
516774	7.5	230/460	Premium
516775	10	230/460	Premium
516776	15	230/460	Premium
516828	20	230/460	Premium
51B681	7.5	380V/50Hz	Premium
51B682	10	380V/50Hz	Premium
51B683	15	380V/50Hz	Premium
51B684	20	380V/50Hz	Premium

General Motor Specification:

Class1, Group D, Division 1 Explosion Proof, Temp. Code T2B, Class F Insulation, Vertical.

Technical Data

Power Supply required	220/575 Volt AC, 3-phase, 50/60 Hz
Flow Rate	0–50 gpm (0–189 liter/min)
Fluid Inlet and Outlet Size	2 in. npt(f)
Wetted Parts	Stainless Steel, PTFE, Viton®, Delrin®, Teflon-Coated Iron

Viton® and Delrin® are registered trademarks of the DuPont Co.

Graco Standard Warranty

Graco warrants all equipment manufactured by Graco and bearing its name to be free from defects in material and workmanship on the date of sale by an authorized Graco distributor to the original purchaser for use. With the exception of any special, extended, or limited warranty published by Graco, Graco will, for a period of twelve months from the date of sale, repair or replace any part of the equipment determined by Graco to be defective. This warranty applies only when the equipment is installed, operated and maintained in accordance with Graco's written recommendations.

This warranty does not cover, and Graco shall not be liable for general wear and tear, or any malfunction, damage or wear caused by faulty installation, misapplication, abrasion, corrosion, inadequate or improper maintenance, negligence, accident, tampering, or substitution of non-Graco component parts. Nor shall Graco be liable for malfunction, damage or wear caused by the incompatibility of Graco equipment with structures, accessories, equipment or materials not supplied by Graco, or the improper design, manufacture, installation, operation or maintenance of structures, accessories, equipment or materials not supplied by Graco.

This warranty is conditioned upon the prepaid return of the equipment claimed to be defective to an authorized Graco distributor for verification of the claimed defect. If the claimed defect is verified, Graco will repair or replace free of charge any defective parts. The equipment will be returned to the original purchaser transportation prepaid. If inspection of the equipment does not disclose any defect in material or workmanship, repairs will be made at a reasonable charge, which charges may include the costs of parts, labor, and transportation.

THIS WARRANTY IS EXCLUSIVE, AND IS IN LIEU OF ANY OTHER WARRANTIES, EXPRESS OR IMPLIED, INCLUDING BUT NOT LIMITED TO WARRANTY OF MERCHANTABILITY OR WARRANTY OF FITNESS FOR A PARTICULAR PURPOSE.

Graco's sole obligation and buyer's sole remedy for any breach of warranty shall be as set forth above. The buyer agrees that no other remedy (including, but not limited to, incidental or consequential damages for lost profits, lost sales, injury to person or property, or any other incidental or consequential loss) shall be available. Any action for breach of warranty must be brought within two (2) years of the date of sale.

Graco makes no warranty, and disclaims all implied warranties of merchantability and fitness for a particular purpose in connection with accessories, equipment, materials or components sold but not manufactured by Graco. These items sold, but not manufactured by Graco (such as electric motors, switches, hose, etc.), are subject to the warranty, if any, of their manufacturer. Graco will provide purchaser with reasonable assistance in making any claim for breach of these warranties.

In no event will Graco be liable for indirect, incidental, special or consequential damages resulting from Graco supplying equipment hereunder, or the furnishing, performance, or use of any products or other goods sold hereto, whether due to a breach of contract, breach of warranty, the negligence of Graco, or otherwise.

FOR GRACO CANADA CUSTOMERS

The parties acknowledge that they have required that the present document, as well as all documents, notices and legal proceedings entered into, given or instituted pursuant hereto or relating directly or indirectly hereto, be drawn up in English. Les parties reconnaissent avoir convenu que la rédaction du présente document sera en Anglais, ainsi que tous documents, avis et procédures judiciaires exécutés, donnés ou intentés à la suite de ou en rapport, directement ou indirectement, avec les procédures concernées.

Graco Phone Numbers

TO PLACE AN ORDER, contact your Graco distributor, or call this number to identify the distributor closest to you:
1-800-367-4023 Toll Free.

*All written and visual data contained in this document reflects the latest product information available at the time of publication.
Graco reserves the right to make changes at any time without notice.*

Sales Offices: Minneapolis, Detroit
International Offices: Belgium, Korea, Hong Kong, Japan

GRACO INC. P.O. BOX 1441 MINNEAPOLIS, MN 55440-1441

www.graco.com

PRINTED IN USA 308060 June 1990, Revised July 2003