

Instructions – Parts List



STAINLESS STEEL OR CARBON STEEL

Air-Powered Glutton® Pumps

307843AB

100 psi (0.7 MPa, 7 bar) Maximum Incoming Air Pressure

400 Series Pumps

400 psi (2.8 MPa, 28 bar) Maximum Fluid Working Pressure

Model 220663, Series D

Model 237008, Series A

Carbon steel pumps*

Model 220666, Series D

Model 237011, Series A

Stainless steel pumps*

Electro-polished for use with waterborne coatings

1200 Series Pumps

1200 psi (8 MPa, 83 bar) Maximum
Fluid Working Pressure

Model 220664, Series D

Model 237009, Series A

Carbon steel pumps*

Model 220667, Series D

Model 237012, Series A

Stainless steel pumps*

Electro-polished for use with waterborne coatings

2500 Series Pumps

2500 psi (17 MPa, 170 bar) Maximum Fluid
Working Pressure

Model 220665, Series D

Model 237010, Series A

Carbon steel pumps*

Model 220668, Series D

Model 237013, Series A

Stainless steel pumps*

Electro-polished for use with waterborne coatings

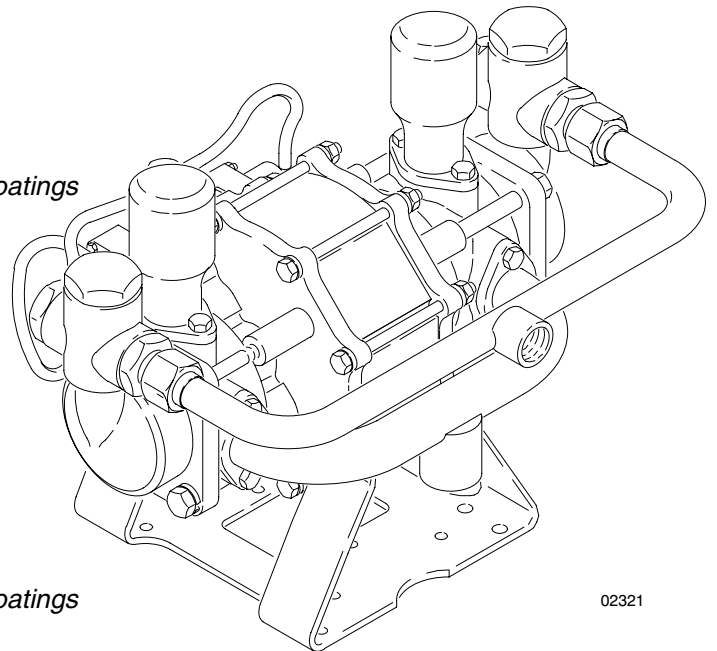

02321

U.S. Patent No. 4,029,442; 4,036,019;
and other foreign and U.S. patents pending.



Important Safety Instructions

Read all warnings and instructions in this manual.
Save these instructions.

*See **TECHNICAL DATA** on pages 43 through 45
for a complete materials list.

PROVEN QUALITY. LEADING TECHNOLOGY.

GRACO INC. P.O. BOX 1441 MINNEAPOLIS, MN 55440-1441
Copyright 1988, Graco Inc. is registered to I.S. EN ISO 9001

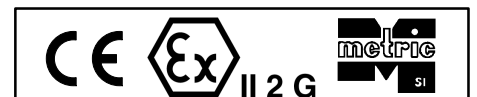

Table of Contents

Warnings	3
Installation	6
Operation	10
Troubleshooting	12
Maintenance	14
Service	15
Parts Drawing and List	
400 Series Carbon Steel Pumps, Models 220663 and 237008	24
400 Series Stainless Steel Pumps, Models 220666 and 237011	26
1200 Series Carbon Steel Pumps, Models 220664 and 237009	28
1200 Series Stainless Steel Pumps, Models 220667 and 237012	30
2500 Series Carbon Steel Pumps, Models 220665 and 237010	32
2500 Series Stainless Steel Pumps, Models 220668 and 237013	34
Air Control Valve 220902	36
Pilot Valve 221133	37
Repair and Conversion Kits	38
Filter, Regulator, Lubricator Kit 222345	40
Drum Cover Kit 222655	41
Return Tube Kit 223319	41
Suction Kit 208259	42
Bearing/Wiper Tool 183888	42
Technical Data and Performance Chart	
400 Series Pumps	43
1200 Series Pumps	44
2500 Series Pumps	45
Dimensional Drawing	46
Mounting Hole Layout	46
Graco Standard Warranty	48
Graco Information	48

Warnings

Warning Symbol



This symbol alerts you to the possibility of serious injury or death if you do not follow the instructions.

Caution Symbol



This symbol alerts you to the possibility of damage to or destruction of equipment if you do not follow the instructions.

! WARNING



SKIN INJECTION HAZARD

Spray from the gun, leaks or ruptured components can inject fluid into your body and cause extremely serious injury, including the need for amputation. Fluid splashed in the eyes or on the skin can also cause serious injury.

- Fluid injected into the skin might look like just a cut, but it is a serious injury. **Get immediate surgical treatment.**
- Do not point the gun at anyone or at any part of the body.
- Do not put your hand or fingers over the spray tip.
- Do not stop or deflect leaks with your hand, body, glove or rag.
- Do not “blow back” fluid; this is not an air spray system.
- Always have the tip guard and the trigger guard on the gun when spraying.
- Check the gun diffuser operation weekly. Refer to the gun manual.
- Be sure the gun trigger safety operates before spraying.
- Lock the gun trigger safety when you stop spraying.
- Follow the **Pressure Relief Procedure** on page 10 whenever you: are instructed to relieve pressure; stop spraying; clean, check, or service the equipment; and install or clean the spray tip.
- Tighten all fluid connections before operating the equipment.
- Check the hoses, tubes, and couplings daily. Replace worn or damaged parts immediately. Permanently coupled hoses cannot be repaired; replace the entire hose.
- Use only Graco approved hoses. Do not remove the spring guard that is used to help protect the hose from rupture caused by kinks or bends near the couplings.

WARNING



INSTRUCTIONS

EQUIPMENT MISUSE HAZARD

Equipment misuse can cause the equipment to rupture or malfunction and result in serious injury.

- This equipment is for professional use only.
- Read all instruction manuals, tags, and labels before operating the equipment.
- Use the equipment only for its intended purpose. If you are uncertain about usage, call your Graco distributor.
- Do not alter or modify this equipment. Use only genuine Graco parts and accessories.
- Check equipment daily. Repair or replace worn or damaged parts immediately.
- Do not exceed the maximum working pressure of the lowest rated system component. Refer to the **Technical Data** section on pages 43 through 45 for the maximum working pressure of this equipment.
- Use fluids and solvents which are compatible with the equipment wetted parts. Refer to the **Technical Data** section of all equipment manuals. Read the fluid and solvent manufacturer's warnings.
- Do not use hoses to pull equipment.
- Route hoses away from traffic areas, sharp edges, moving parts, and hot surfaces. Do not expose Graco hoses to temperatures above 82°C (180°F) or below -40°C (-40°F).
- Do not lift pressurized equipment.
- Comply with all applicable local, state, and national fire, electrical, and safety regulations.
- Never place your hands on or near the pump fluid inlet. Powerful suction could cause serious bodily injury.



MOVING PARTS HAZARD

Moving parts can pinch or amputate your fingers or other body parts.

- Keep clear of all moving parts when starting or operating the equipment.
- Before servicing the equipment, follow the **Pressure Relief Procedure** on page 10 to prevent the equipment from starting unexpectedly.
- Never operate the motor with the pump housing removed.

WARNING



FIRE AND EXPLOSION HAZARD

Improper grounding, poor ventilation, open flames, or sparks can cause a hazardous condition and result in a fire or explosion and serious injury.

- Ground the equipment and the object being sprayed. See **Grounding** on page 7.
- Proper hose grounding continuity is essential in maintaining a grounded spray/dispense system. Check the electrical resistance of your air and fluid hoses at least once a week. If your hose does not have a tag on it that specifies the maximum electrical resistance, contact the hose supplier or manufacturer for the maximum resistance limits. Use a resistance meter in the appropriate range for your hose to check the resistance. If the resistance exceeds the recommended limits, replace it immediately.
- If there is any static sparking or you feel an electric shock while using this equipment, **stop spraying immediately**. Do not use the equipment until you identify and correct the problem.
- Provide fresh air ventilation to avoid the buildup of flammable fumes from solvents or the fluid being sprayed.
- Keep the spray area free of debris, including solvent, rags, and gasoline.
- Electrically disconnect all equipment in the spray area.
- Extinguish all open flames or pilot lights in the spray area.
- Do not smoke in the spray area.
- Do not turn on or off any light switch in the spray area while operating or if fumes are present.
- Do not operate a gasoline engine in the spray area.



HAZARDOUS FLUIDS

Hazardous fluid or toxic fumes can cause serious injury or death if splashed in the eyes or on the skin, inhaled, or swallowed.

- Be sure all fluids and solvents used are chemically compatible with the *wetted parts* shown in the **TECHNICAL DATA** for your pump model. Always read the fluid and solvent manufacturer's literature before using the fluid or solvent in this pump.
- Know the specific hazards of the fluid you are using.
- Store hazardous fluid in an approved container. Dispose of hazardous fluid according to all local, state and national guidelines.
- Always wear protective eyewear, gloves, clothing and respirator as recommended by the fluid and solvent manufacturer.
- Provide for safe piping and disposal of exhaust air.
- Secure the fluid outlet hose tightly into the receiving container to prevent the hose from coming loose and creating a fluid spill.
- Provide proper ventilation in accordance with accepted industry standards and government regulations.

United States Government safety standards have been adopted under the Occupational Safety and Health Act. You should consult these standards – particularly the General Standards, Part 1910, and the Construction Standards, Part 1926.

Installation

Mounting the Pump

- **400 and 1200 Series Pumps:** Mount the pump with the accumulators in the top position as shown in Fig. 1. The accumulators must be in the position shown or the pump will not prime.
- Be sure the pump is securely bolted to its mounting and that the mounting can support the weight of the pump, hoses, and stress caused during operation.
- The outlet manifold can be removed and turned 180 degrees to change the direction of the outlet and ease installation, as shown in Fig. 3.

General Information

- The installation shown in Fig. 4 is only a guide for selecting and installing system components. Contact your Graco distributor for assistance in planning a system to suit your needs.
- See pages 38 through 42 for accessories and kits available from Graco. Always use Genuine Graco Parts and Accessories.
- Use a thread sealant compatible with the fluid being pumped on all male pipe threads. Tighten all connections firmly to avoid air or fluid leaks.
- Reference numbers and letters in parentheses in the text refer to the figure illustrations.

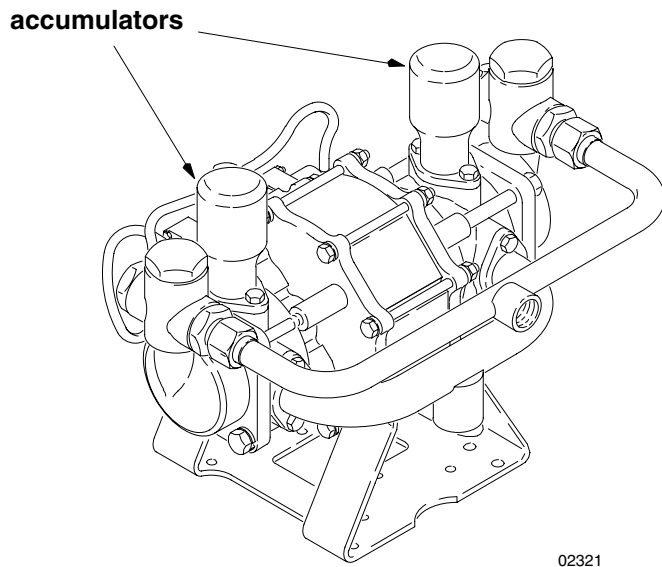

Fig. 1

Installation

Grounding

WARNING

This pump must be grounded. The steps for grounding may differ from the way you ground other pumps. Carefully read and follow these grounding instructions. See **FIRE AND EXPLOSION HAZARD** on page 5 before you operate the pump.

Static electricity is created by the high-velocity flow of fluid through the pump and hose. If every part of the equipment is not properly grounded, sparking may occur. To reduce the risk of static sparking, ground the pump and all other equipment used or located in the pumping area. Check your local electrical code for detailed grounding instructions for your area and type of equipment. *Ground all of the following equipment:*

- *Pump:* use a ground wire and clamp as shown in Fig. 2.
- *Fluid and air hoses:* use only grounded hoses with a maximum of 500 feet (150 m) combined hose length to ensure grounding continuity.

- *Air Compressor:* Follow the manufacturer's recommendations.
- *Spray gun or dispensing valve:* Obtain grounding through connection to a properly grounded fluid hose and pump.
- *Fluid supply container:* Follow the local code.
- *Object being sprayed:* Follow the local code.
- *All solvent pails used when flushing:* Follow the local code. Use only metal pails, which are conductive. Do not place the pail on a non-conductive surface, such as paper or cardboard, which interrupts the grounding continuity.

To ground the pump: Loosen the grounding lug locknut (W) and washer (X). Insert one end of a 12 ga (1.5 mm²) minimum ground wire (Y) into the slot (Z) of the grounding lug, and tighten the locknut securely. Connect the clamp end of the ground wire to a true earth ground. To order a ground wire and clamp, order Part No. 222011.

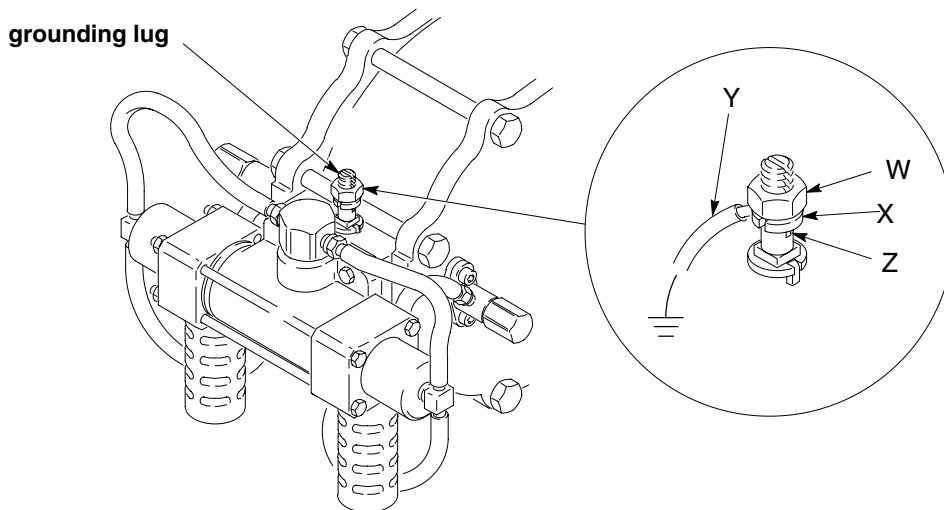

02322

Fig. 2

Installation

Connect the Fluid Lines

1. Use grounded fluid hoses.
 - a. The **pump fluid outlet (J)** on the **400 and 1200 Series Pumps** is 1 npt(f) .
 - b. The **pump fluid outlet (J)** on the **2500 Series Pump** is 3/4 npt(f).
2. Install a fluid filter (F) and drain valve (E) near the fluid outlet. See Fig. 3.

⚠ WARNING

A fluid drain valve (E) is required in your system to relieve pressure in the fluid outlet hose (H) if the hose becomes plugged. See Fig. 3. Install a drain valve close to the pump's fluid outlet. The drain valve reduces the risk of property damage or serious bodily injury, including splashing in the eyes or on the skin, or contamination from hazardous fluids.

3. Install a control device, such as a gun, dispensing valve, or shutoff valve, on the grounded fluid hose (H).

Connect the Fluid Suction Line

⚠ CAUTION

The pump must be suction fed in order to operate properly. Pressure feeding or exceeding 15 psi (104 kPa, 1.04 bar) maximum fluid inlet pressure may cause premature bellows seal failure.

Connect the fluid suction hose (S) to the pump fluid inlet (M). See Fig. 4.

- The pump fluid inlet (M) is 1.25 npt(f).
- The maximum suction lift is 15 ft (4.57m) for the 400 Series and 1200 Series Pumps, and 6 ft (1.83 m) for the 2500 Series Pump.

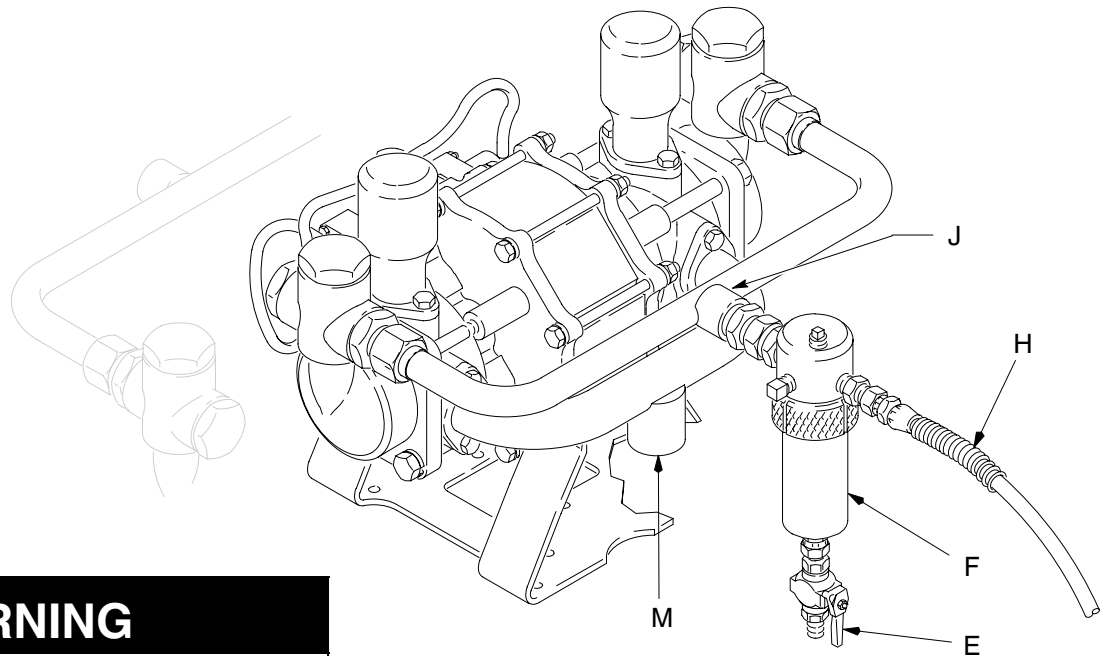

⚠ WARNING

SUCTION HAZARD

Never place your hands on or near the pump fluid inlet. Powerful suction could cause serious bodily injury.

0232E

Fig. 3

Installation

Connect the Air Lines

1. Install the air line accessories to the left of the pump as shown in Fig. 4. Mount these accessories on the wall or on a bracket. Be sure the air line supplying the accessories is grounded.
2. Install a flexible air hose between the accessories and the 1/2 in. npt(f) air inlet (G). Use a minimum 1/2 in. ID air hose.
3. Install an air line lubricator (B) upstream from the pump air inlet for automatic pump lubrication.
4. Install a pump runaway valve (T) to sense when the pump is running too fast and shut off the air supply to the motor. To order a pump runaway valve, order Part No. 224040.
5. Install an air regulator (D) to control air inlet pressure.

6. Install one bleed-type master air valve (C) downstream from the air regulator and use it to relieve trapped air. Locate the other master air valve upstream from all air line accessories and use it to isolate the accessories during cleaning and repair.
7. Install an air line filter (A) to remove harmful dirt and moisture from your compressed air supply.
8. Install a grounded air supply line (P) with a minimum 1/2 in. ID. See Fig. 4.

Ventilate the Air Exhaust

⚠ WARNING

Improper handling of hazardous fluids or inhaling their vapors can cause serious bodily injury, even death. For your safety, it is imperative that you read all product warning labels and Material Safety Data Sheets (MSDS) for the fluids you are using. An MSDS can be obtained from your fluid suppliers. It is also important that you read and understand the warnings and precautions regarding **HAZARDOUS FLUID HAZARD** on page 5 before you operate.

All systems using hazardous fluid in enclosed areas or within buildings should have a properly designed and installed ventilation system. Consult your local building code and other industrial and governmental standards for proper design criteria.

⚠ WARNING

A bleed-type master air valve (C) is required in your system to relieve air trapped between this valve and the pump after the air regulator is closed. Trapped air can cause the pump to cycle unexpectedly, which could result in serious bodily injury, including splashing in the eyes, injury from moving parts, or contamination from hazardous fluids.

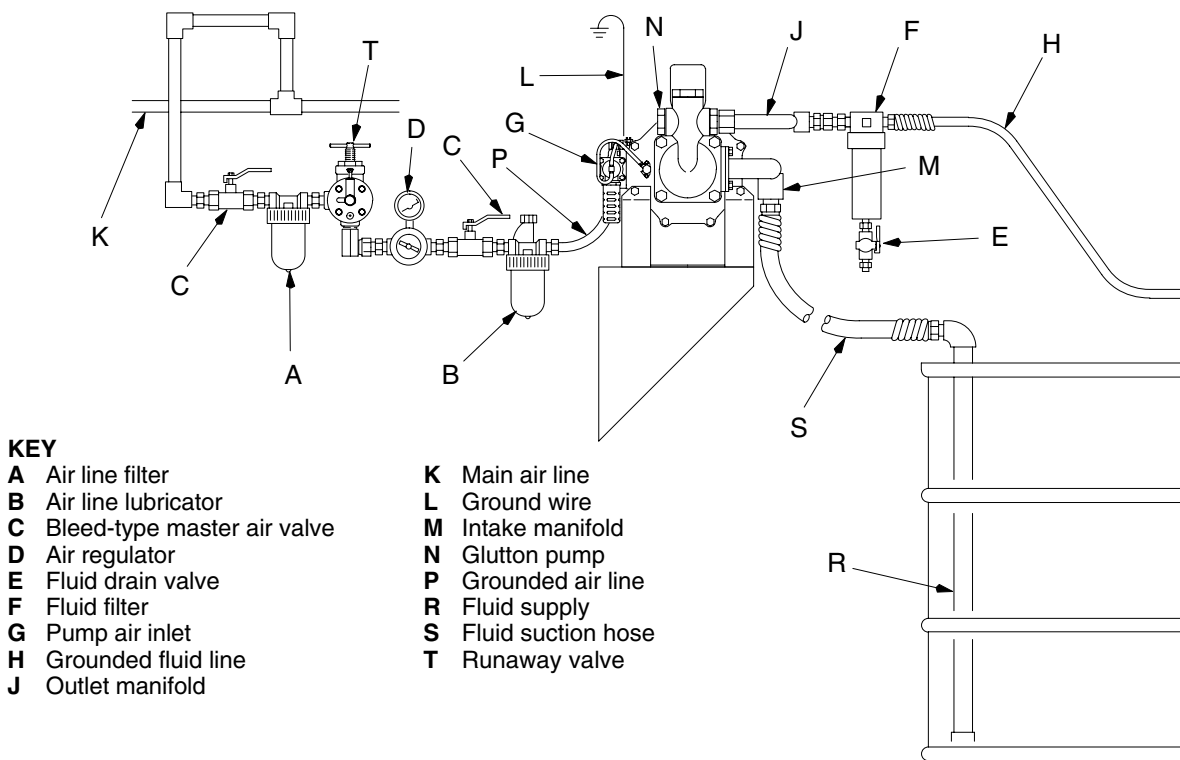

Fig. 4

02323

Operation

Pressure Relief Procedure

WARNING

The system pressure must be manually relieved to prevent the system from starting or spraying accidentally. To reduce the risk of an injury from accidental spray from the gun, splashing fluid, or moving parts, always follow the **Pressure Relief Procedure** whenever you

- are instructed to relieve the pressure
- Stop spraying
- Check or service any of the system equipment
- install or clean the spray nozzle.

1. * Engage the spray gun or dispensing valve safety latch.
 2. Shut off the air supply.
 3. * Disengage the gun or dispensing valve safety latch.
 4. * Hold a metal part of the gun or valve firmly to a grounded metal waste container and trigger it to relieve the fluid pressure.
 5. * Engage the safety latch again.
 6. Open the pump drain valve (required in system), and have a container ready to catch the drainage.
 7. Leave the drain valve open until you are ready to spray again.
- * *Applies only when using a spray gun or dispensing valve.*

If you suspect that the spray tip, nozzle, or hose is clogged or that pressure has not been fully relieved after following the steps above, very slowly loosen the hose end coupling and relieve pressure gradually, then loosen completely, then clear the tip, nozzle, or hose obstruction.

Flush the Pump Before First Use

WARNING

To reduce the risk of fluid injection injury, static sparking and splashing, read and follow **Flushing Safety** under **FIRE OR EXPLOSION HAZARD** on page 5.

The pump was tested with lightweight oil, which is left in to protect the pump parts. If this solution could contaminate the fluid you are pumping, flush it thoroughly with a compatible solvent. To start the pump, follow the procedure in **Start and Adjust the Pump**, below.

Start and Adjust the Pump

NOTE: Check all fittings to be sure they are tight. Be sure to use a thread sealant compatible with the fluid being pumped on all male pipe threads.

1. Place the suction hose (S) in the fluid to be pumped. See Fig. 5.
2. Close the fluid drain valve (E).
3. With the air regulator (D) closed, open both bleed-type master air valves (C).
4. Open the fluid control device while continuing with the following steps.
5. Slowly open the air regulator (D). Adjust it until the pump runs smoothly.
6. Allow the pump to cycle slowly until all air is pushed out of the lines (the fluid will be flowing in a steady stream from the fluid outlet) and the pump is primed.

WARNING

To reduce the risk of component rupture, which could cause serious bodily injury, **never** exceed 100 psi (0.7 MPa, 7 bar) air supply pressure to the pump. Read the warning section **EQUIPMENT MISUSE HAZARD** on page 4.

Operation

7. If you are flushing:
 - a. Run the pump long enough to thoroughly clean the pump and hoses.
 - b. Close the fluid control device and air regulator (D).
 - c. Remove the suction hose (S) from the solvent and place it in the fluid to be pumped.
8. If you are going to use the pump:
 - a. Start the pump. Be sure the suction hose is in the supply container.
 - b. If you are using this pump to spray fluid, **relieve the pressure**, then install a spray tip in the gun. Trigger the gun into a grounded metal waste container to prime the hose. Adjust the pump pressure just enough to completely atomize the fluid. Higher pressures cause premature spray tip and pump wear.

⚠ WARNING

PRESSURIZED EQUIPMENT HAZARD

To reduce the risk of a serious injury whenever you are instructed to relieve pressure, follow the **Pressure Relief Procedure** on page 10.

- c. In a direct supply system, the pump will start and stop as the spray gun, dispensing valve, or fluid outlet valve is opened and closed.
- d. In a circulating system, the pump runs continuously and speeds up or slows down as supply demands until the air supply is shut off.

⚠ CAUTION

Never allow the pump to run dry of fluid. A dry pump will accelerate to a high speed, possibly damaging itself. If your pump accelerates quickly, or is running too fast, **stop it immediately** and check the fluid supply. If the supply is empty and air has been pumped into the lines, refill the container and prime the pump and lines with fluid, or flush and leave filled with compatible solvent. Be sure to eliminate all air from the system. A Pump Runaway Valve, Part No. 224040, is available.

9. If you are shutting down the pump:
 - a. Flush the pump before shutting down, especially if pumping a material that will set up.
 - b. Remove the suction hose from the fluid container and run the pump until the fluid is forced out of the system, then shut off the air supply immediately.
 - c. **Relieve the pressure.**

⚠ WARNING

PRESSURIZED EQUIPMENT HAZARD

To reduce the risk of a serious injury whenever you are instructed to relieve pressure, follow the **Pressure Relief Procedure** on page 10.

- d. Refer to the **Maintenance instructions** on page 14.

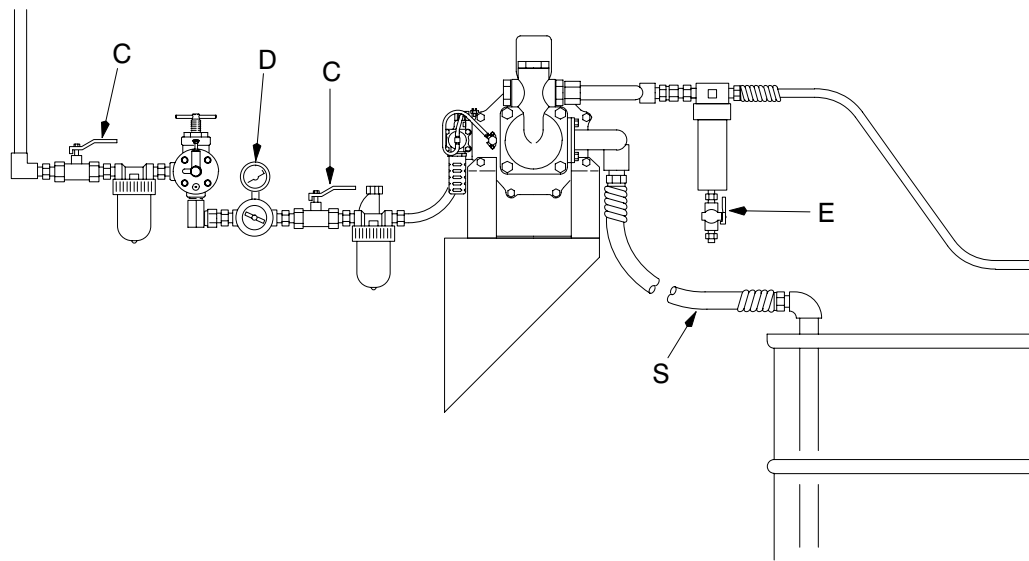

Fig. 5

02323

Troubleshooting

Relieve the pressure, and check all probable causes before disassembling the pump.

WARNING

PRESSURIZED EQUIPMENT HAZARD

To reduce the risk of a serious injury whenever you are instructed to relieve pressure, follow the **Pressure Relief Procedure** on page 10.

SYMPTOM	PROBABLE CAUSE	TEST PROCEDURE	REMEDY
1. Pump will not prime	<p>Air is getting into the intake housing:</p> <ul style="list-style-type: none"> a. Defective o-ring (19) on intake manifold or accumulator b. Suction hose/tube not sealed 		<ul style="list-style-type: none"> a. Replace o-ring. See page 15. b. Tighten, or add sealant to threads
2. Pump will not run	<ul style="list-style-type: none"> a. Air supply turned off b. Fluid valve turned off c. Air pressure regulator set too low d. Pilot valve assemblies worn e. Air control valve defective f. Air piston quad ring (28) worn 	<ul style="list-style-type: none"> c. Minimum air pressure on regulator 25 psi (175 kPa, 1.95 bar), depending on fluid being pumped d. Remove tube ends from hose studs. With air supply on, alternately plug tube ends. If pump runs, remove pilot valves, inspect e. Check for air coming from exhaust when pump is not running 	<ul style="list-style-type: none"> a. Turn air supply on b. Turn fluid supply valve on c. Increase air pressure regulator adjustment d. Repair or replace pilot valve assembly. See page 22. e. Repair or replace air control valve. See page 20. f. Replace quad ring. See page 18.

Troubleshooting

SYMPTOM	PROBABLE CAUSE	TEST PROCEDURE	REMEDY
3. Pump runs but does not maintain constant pressure	<ul style="list-style-type: none"> a. Air in fluid line b. Air line too small c. Obstructed or worn ball (57) and seat (49) d. Worn fluid piston (17) and/or piston seal (13) e. Air control valve mufflers (38) plugged f. Air control valve dirty or worn g. Lack of lubrication h. Dirty air passages 	<ul style="list-style-type: none"> a. Check for spitting at fluid line outlet c. Pump fast cycles on one end of stroke indicates that side is bypassing d. Pump fast cycles on one end of stroke indicates that side is bypassing e. Check for slow air flow at muffler g. Pump reacts slowly h. Check for sluggish air control valve operation 	<ul style="list-style-type: none"> a. Bleed fluid line until constant flow is obtained b. Install larger air line, minimum size 1/2 in. c. Remove, clean, and inspect seat, ball, and ball guide (56). Replace if worn. See page 15. d. Replace piston and/or seal. See page 16. e. Remove and clean mufflers f. Repair or replace air control valve. See page 20. g. Adjust lubricator h. Clean air passages; do not enlarge orifices. Empty air line filter and/or control valve filter (40q). See step 5 in Disassembly on page 20.
4. Paint dripping externally around piston rod	<ul style="list-style-type: none"> a. Ruptured bellows seal (14) 	<ul style="list-style-type: none"> a. Check for presence of paint around piston shaft (15) 	<ul style="list-style-type: none"> a. Replace bellows seal. See page 16. Be sure to suction feed, not pressure feed, pump. Maximum fluid inlet pressure is 15 psi (104 kPa, 1.04 bar)

Maintenance

Flush the Pump With Compatible Solvent

WARNING

To reduce the risk of fluid injection injury, static sparking and splashing, read and follow **Flushing Safety** under **FIRE OR EXPLOSION HAZARD** on page 5.

1. Flush often enough to prevent fluid from drying in the pump and damaging it.
2. **Always** flush before storing.
 - a. If you are pumping water-based fluid, first flush the pump with water, then with mineral spirits or a compatible oil-based solvent.
 - b. Leave the mineral spirits or oil-based solvent in the pump to protect the pump parts from corrosion.

3. Be sure to eliminate all air from the system.

Tighten Threaded Connections

1. Before each use, check all hoses for wear or damage and replace as necessary. Be sure all threaded connections are tight, and leak-free.
2. At least every six months, check and tighten all threaded connections, including manifold screws, clamps, plugs, and valve screws.

Check and Service the Lubricator, Regulator, and Filter

Check and service according to the instructions supplied with them. See Manual 308169 for oil recommendations.

Service

Repairing the Ball Check Valves

NOTE: Parts marked with an asterisk are included in a repair kit, for example, (54*). See pages 38 and 39 for repair kit part numbers. Use all the parts in the kit for the best results.

Disassembly

1. Relieve the pressure.

WARNING

PRESSURIZED EQUIPMENT HAZARD

To reduce the risk of a serious injury whenever you are instructed to relieve pressure, follow the **Pressure Relief Procedure** on page 10.

2. Disconnect the air and fluid lines, remove the pump from its mounting, and place it on a bench.
3. Remove the cap (53) from each side of the outlet housing (33). See Fig. 6.
4. Remove the ball (57), ball guide (56), valve seat (49), and o-ring (48*) on each side of the outlet housing.
5. Inspect the ball stop (55) inside the cap (53) for wear. Replace if necessary.
6. Clean all parts and inspect for wear or damage. Replace as needed.

Assembly

NOTE: The valve seat (49) is reversible as it is lapped on both sides.

1. Lubricate the o-rings (48*) and place one in the groove on each valve seat (49).
2. Install the valve seat (49) with the o-ring (48) facing down, ball guide (56), and ball (57) into each outlet housing (33).
3. Lubricate the o-rings (54*) and the cap (53) threads. Place one o-ring on each cap. Screw the caps into the housing and torque them to 55 to 85 ft-lb (75 to 115 N•m).

NOTE: On stainless steel pumps (Models 220666 through 220668 and Models 237011 to 237013), apply anti-seize lubricant to the threads of the cap (53).

Repairing the Fluid Piston and Seal

NOTE: Parts marked with an asterisk are included in a repair kit, for example, (52*). See pages 38 and 39 for repair kit part numbers. Use all the parts in the kit for the best results.

Disassembly

1. Relieve the pressure.

WARNING

PRESSURIZED EQUIPMENT HAZARD

To reduce the risk of a serious injury whenever you are instructed to relieve pressure, follow the **Pressure Relief Procedure** on page 10.

2. Loosen the tube nuts (A) and remove the outlet manifold (50). Unscrew the connectors (51). See Fig. 6.
3. Remove the screws (34), washers (35), outlet housing (33), piston seal (13*) and retaining plate (12). Repeat on the other side of the pump.
4. Holding the screw (16) on one side of the pump, loosen the screw three or four turns on the opposite side of the pump, using a socket and breaker bar.
5. Remove the piston (17) by grasping it with your hand and hit screw (16) with a plastic mallet to drive piston loose from shaft. Remove screw (16) and piston (17).
6. Holding the piston shaft (15) flats with a wrench, remove the remaining screw (16).
7. Repeat steps 8 and 9 on the opposite end of the pump. Clean all parts and inspect for wear or damage. Replace as needed.
8. Remove the screws (32), washers (46 or 61), and inlet manifold (47).
9. Remove the intake housing (36), bellows (14*), and retaining plate (20).

Service

Assembly

1. Slide the retaining plate (20), bellows (14*), and intake housing (36) onto the piston shaft (15). **Do not** force the bellows.

CAUTION

To avoid damaging the bellows (14), **do not** force it onto the shaft. The bellows will press into place when the piston (17) is secured.

2. Replace o-ring (19*) in each inlet. Install inlet manifold (47) with screws (32) and washers (46 or 61). Don't torque screws yet.
3. Install the piston (17) on the shaft (15) and secure it with the screw (16). Repeat on the opposite end of the pump.
4. Using a socket and breaker bar, torque one screw (16) to 40 to 50 ft-lb (54 to 67 N•m), then repeat with the other screw.

CAUTION

To avoid loosening the piston stud (30) during disassembly, **do not** overtighten the screws (16).

NOTE: If assembling a 400 or 800 series Glutton pump, proceed to step 5. If assembling a 1200 series Glutton pump, proceed to step 6 for seal installation.

5. Replace the o-ring (18*) in the groove in the tapered side of the retaining plate (12). Install the retaining plate (12), piston seal (13*), and outlet housing (33). Be sure the flat side of the retaining plate faces the piston seal. Secure with the four screws (34) and washers (35).

6. Drive the piston (17) all the way in to the intake housing. Tip the pump onto its side with the recessed piston up. Replace the o-ring (18*) in the groove in the tapered side of the retaining plate (12). Install the retaining plate (12).

Grease the outlet housing groove and set the nylon seal inside the groove. Lay a steel rule or similar plate across the seal and housing. Tip the housing onto the inlet housing and carefully pull the steel ruler out from between the housings. Be sure the flat side of the retaining plate faces the piston seal. Secure with the four screws (34) and washers (35).

Apply a low-pressure burst of air to the air manifold just until the piston drives to the other side. This will form the seal on one side and move the piston into the inlet housing on the other side. Repeat the seal installation pattern.

NOTE: Torque the screws, on 400 and 1200 Series pumps, to 40 to 50 ft-lb (54 to 68 N-m). Torque the screws on the 2500 Series pump, to 35 to 40 ft-lb (47 to 54 N-m).

7. Torque the inlet manifold screws (32) to 7.4 to 12.5 ft-lb (10 to 17 N-m).
8. Replace the o-ring (52*) in each outlet manifold connector (51) and lubricate the threads. Install the outlet manifold (50), torquing the connectors to 55 to 85 ft-lb (75 to 115 N•m).

NOTE: On stainless steel pumps (Models 220666 through 220668 and Models 237011 to 237013), apply anti-seize lubricant to the threads of the connector (51).

Service

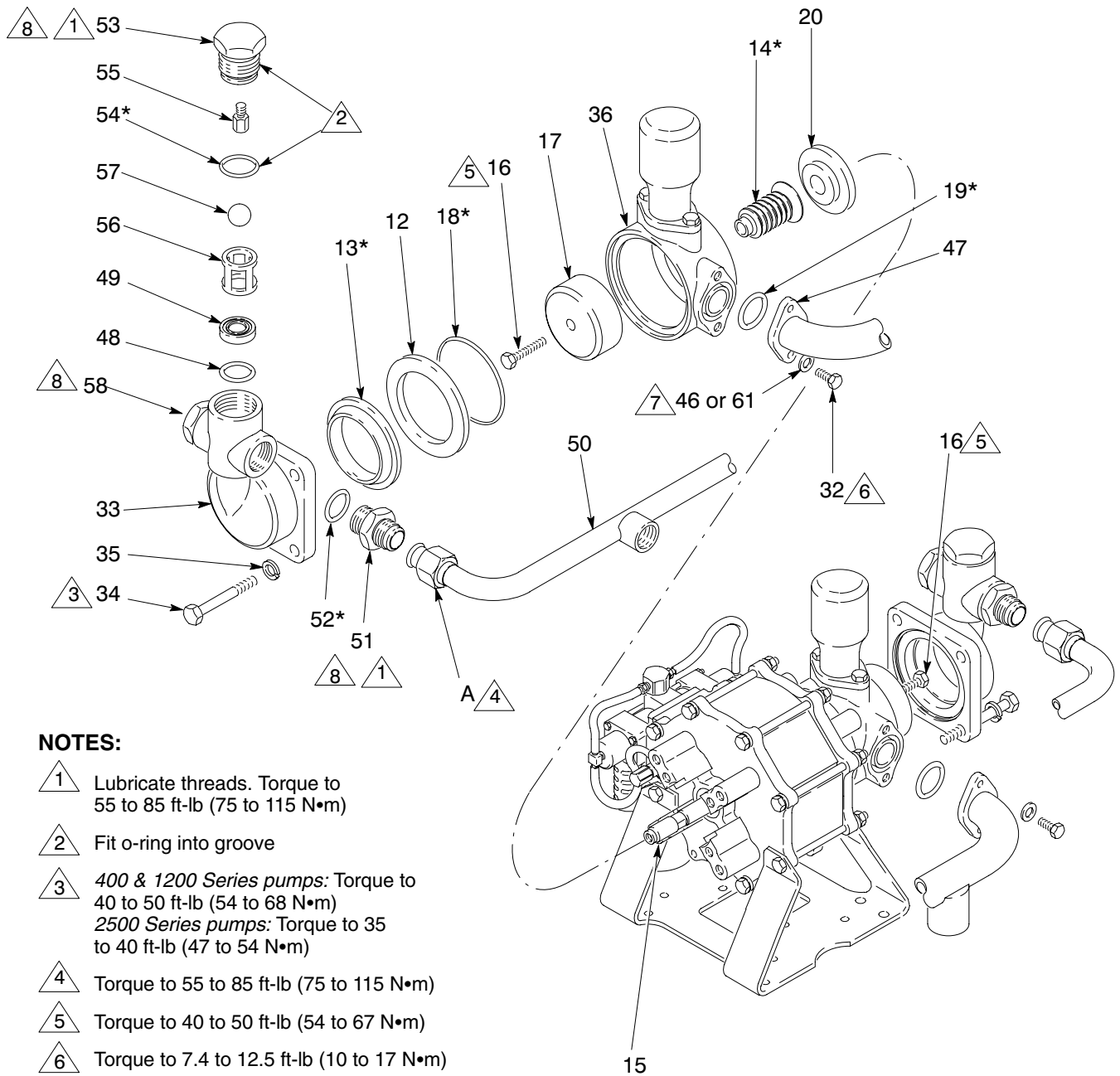

NOTES:

- 1** Lubricate threads. Torque to 55 to 85 ft-lb (75 to 115 N•m)
- 2** Fit o-ring into groove
- 3** 400 & 1200 Series pumps: Torque to 40 to 50 ft-lb (54 to 68 N•m)
2500 Series pumps: Torque to 35 to 40 ft-lb (47 to 54 N•m)
- 4** Torque to 55 to 85 ft-lb (75 to 115 N•m)
- 5** Torque to 40 to 50 ft-lb (54 to 67 N•m)
- 6** Torque to 7.4 to 12.5 ft-lb (10 to 17 N•m)
- 7** Item 61 is used on stainless steel models only
- 8** On stainless steel pumps (Models 220666 through 220668 and Models 237011 to 237013), apply anti-seize lubricant to the threads.

02326

Fig. 6

Service

Repairing the Air Motor and Piston

NOTE: Parts marked with an asterisk are included in a repair kit, for example, (23*). See pages 38 and 39 for repair kit part numbers. Use all the parts in the kit for the best results.

Disassembly

1. Relieve the pressure.

WARNING

PRESSURIZED EQUIPMENT HAZARD

To reduce the risk of a serious injury whenever you are instructed to relieve pressure, follow the **Pressure Relief Procedure** on page 10.

2. Disassemble the pump as instructed under **Repairing the Fluid Piston and Seal**.
3. Remove the screws (3 & 4), washers (46), nuts (1), and lockwashers (2) from the cylinder cap (25). See Fig. 7.
4. Remove the pump from the mounting bracket (44).
5. Remove the cylinder cap (25) from each end of the air motor. If the hoses aren't disconnected or the pilot valves removed, be careful not to pull on the hoses when removing the caps.

CAUTION

Remove the bearing (22) only if it needs to be replaced. Removal will damage it.

6. Remove the shaft wiper (21), bearing (22); *only if it needs to be replaced*, and u-cup (23*) from each of the cylinder caps (25). Use a 0.875 in. diameter shaft to remove the bearing.
7. Remove the piston assembly (A) from the air motor cylinder (27).

8. **Do not** remove the piston shafts (15) unless replacement is necessary as a high strength sealant was used on the threads. If the rods must be removed, heating the joint to 300° F will ease disassembly. Place wrenches on the flats of the piston shaft to disconnect them from the piston stud (30).
9. Clean all parts and inspect for wear or damage. Replace as needed.

Assembly

1. Apply lithium base grease to all packings, seals, and the inside of the air motor cylinder (27) before assembling.
2. If the piston shafts (15) were removed from the piston stud (30), apply high strength sealant (such as Loctite®) to the threads of the piston stud, and assemble as shown in Fig. 7.
3. Install the quad ring (28*) in the groove on the piston (29). Install the piston assembly (A) into the air motor cylinder (27).
4. Install a u-cup (23*) into each of the cylinder caps (25). The lips of the u-cup must face in, towards the center of the pump, as shown in Fig. 8.
5. If the bearings (22) were removed, install a bearing into each cylinder cap (25). Press fit the bearing to flush, using the Bearing/Wiper Tool 183888 and an arbor press.
6. Install a shaft wiper (21) into each cylinder cap (25) with the brass part of the wiper facing out, away from the center of the pump, as shown in Fig. 8. Carefully press the wiper into place, using the Bearing/Wiper Tool 183888, to avoid damaging the brass piece.
7. Install an o-ring (26*) into the groove in each of the cylinder caps (25). Slide a cylinder cap (25) onto each end of the air motor.
8. Secure the mounting bracket (44) and cylinder caps (25) on the pump with the screws (3 and 4), washers (46), nuts (1), and lockwashers (2). Torque the screws to 7.4 to 12.5 ft-lb (10 to 17 N•m).

Service

NOTES:

- 1 Take care not damage tubes when removing cap (25)
- 2 Apply high-strength sealant to threads
- 3 Torque to 7.4 to 12.5 ft-lb (10 to 17 N•m)
- 4 Press fit to flush using Tool 183888
- 5 Press fit to bottom using Tool 183888

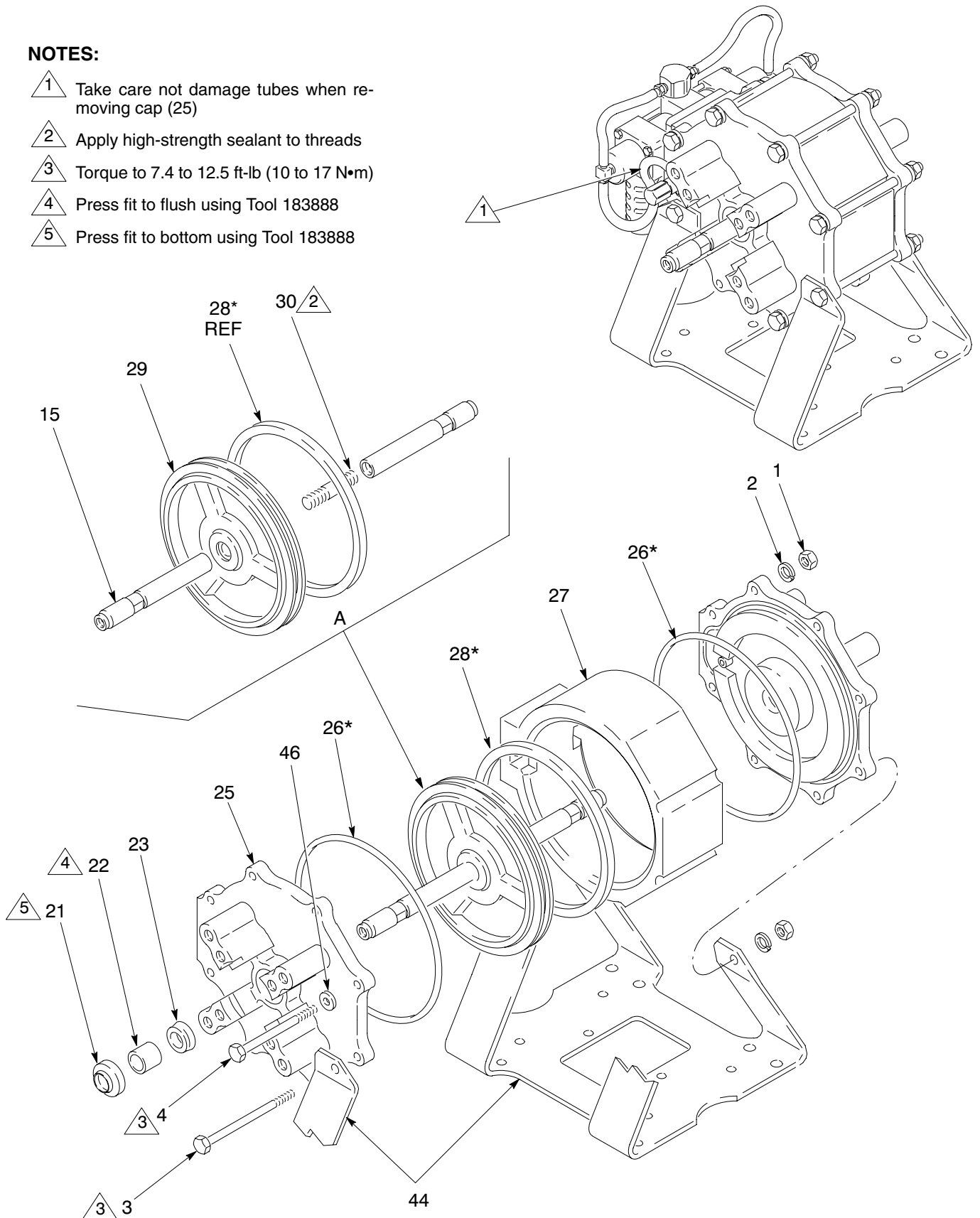

Fig. 7

02327

Service

Repairing the Air Control Valve

NOTE: Air Valve and Pilot Valve Repair Kit 220656 is available. See page 38 to order. Parts included in the kit are marked with an asterisk, for example, (40p*). Use all the parts in the kit for the best results.

Disassembly

1. Relieve the pressure.

WARNING

PRESSURIZED EQUIPMENT HAZARD

To reduce the risk of a serious injury whenever you are instructed to relieve pressure, follow the **Pressure Relief Procedure** on page 10.

2. Cut a small slit in the tube ends (72*, 42*, 40p*) and disconnect them from the pilot valve fittings (5h), air valve tees (40n), and barb fittings (40s). See Fig. 8.
3. Remove the valve end housings (40b) by unscrewing the screws (40k) and nuts (40m).
4. Center the valve spools (40c) in the housing (40a). Remove the spools and stem (40d) by applying opposing force with wrenches on the spool (40c) flats.
5. If the air filter (40q) needs cleaning or replacement, unscrew the filter housing (40r) and remove the filter. To clean them, soak the filter housing and the filter in solvent until they are clean. Blow them dry with low pressure air [under 30 psi (207 MPa, 2.1 bar)]. Press fit the filter into the housing, using 40 to 60 lb (18 to 27 kg) of force. Refer to Fig. 8. Apply sealant to the filter housing threads and turn it into the center housing (40a).

Assembly

1. Apply lithium-base grease to all o-rings, u-cups, gaskets and to the complete spool assembly before installing them.
2. Remove the seal retainers (40e) from each side of the center housing (40a). Replace the u-cup (40j*), with the lips facing into the housing. Install the retainers with the flat side facing into the housing.

3. Replace the spools (40c) if damaged. Replace the o-ring (40h*) and u-cup (40i*) on each spool, being sure to seat them in the grooves. Install the u-cup with the lips facing towards the housing (40a).
4. Apply medium strength thread sealant to the spool stem (40d) threads. Remove the excess sealant.
5. Thread one spool (40c) onto the stem (40d) and insert it into the center housing (40a); be careful not to dislodge the u-cups (40j) and retainers (40e). Thread the other spool onto the stem. With wrenches on the flats of the spools, apply opposing force and tighten until snug; 7 to 13 in-lb (0.79 to 1.47 N•m). **Do not** overtighten.

CAUTION

Do not overtighten the spools (40c) as this can shear the spool threads.

6. Replace the gasket (40f*) in each end housing (40b) and the o-ring (40g*) on each end housing shoulder.
7. With the mufflers facing down, install the end housings (40b), onto the center housing (40a); be careful not to move the spool and dislodge the u-cups (40j) and retainers (40e). Secure the end housings with the four screws (40k) and nuts (40m), torquing them to 2.2 to 3.7 ft-lb (3 to 5 N•m).

CAUTION

If mufflers (38) are replaced, they must be installed with the lock rings (39) to avoid damage to the spool and o-rings during operation.

8. Replace the two o-rings (40h*) in the center housing (40a).
9. Install the air valve on the pump with the four cap screws (43). Torque them alternately and evenly to 2.2 to 3.7 ft-lb (3 to 5 N•m).
10. Connect the new tubes (72*, 42*, 40p*) to the pilot valve fittings (5h), air valve tees (40n), and barb fittings (40s), as shown in Fig. 8.

Service

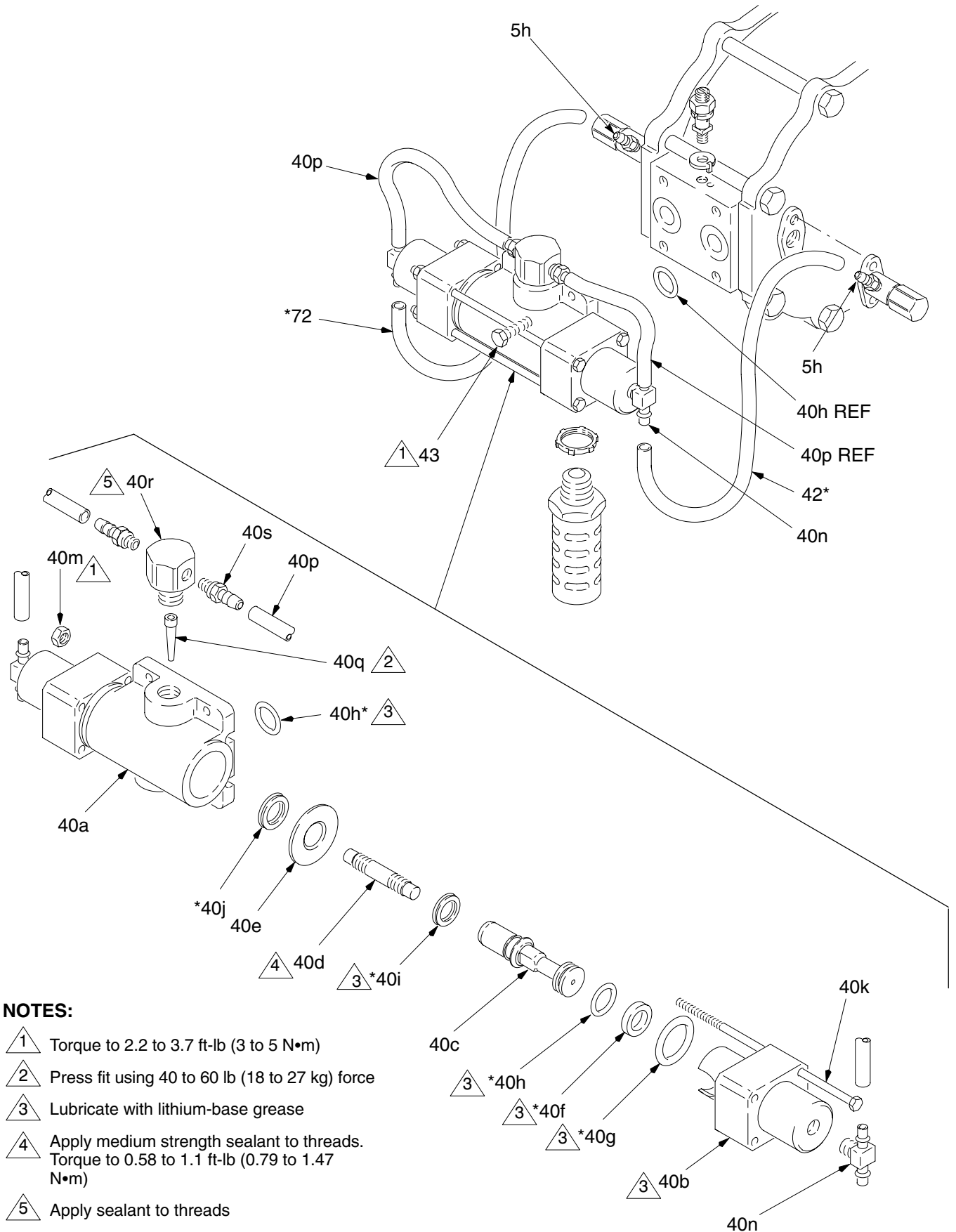

NOTES:

- 1 Torque to 2.2 to 3.7 ft-lb (3 to 5 N•m)
- 2 Press fit using 40 to 60 lb (18 to 27 kg) force
- 3 Lubricate with lithium-base grease
- 4 Apply medium strength sealant to threads. Torque to 0.58 to 1.1 ft-lb (0.79 to 1.47 N•m)
- 5 Apply sealant to threads

Fig. 8

Service

Repairing the Pilot Valve

NOTE: Air Valve and Pilot Valve Repair Kit 220656 is available. See page 38 to order. Parts included in the kit are marked with an asterisk, for example, (5j*). Use all the parts in the kit for the best results.

Disassembly

1. Relieve the pressure.

WARNING

PRESSURIZED EQUIPMENT HAZARD

To reduce the risk of a serious injury whenever you are instructed to relieve pressure, follow the **Pressure Relief Procedure** on page 10.

2. Unscrew the valve cap (5c) from each of the valve housings (5d) and remove the parts. Clean and inspect the parts for damage. See Fig. 9.
3. To replace the rod seal (5j*):
 - a. Cut a small slit in the tube ends (72* and 42*) and disconnect them from the pilot valve fittings (5h) and air valve tees (40n).
 - b. Unscrew the cap screws (37) and remove the pilot valve housings (5d). Grease the rod seals (5j*) and install one on each side of the pump.
 - c. Secure the pilot valve housings (5d) to the pump with the cap screws (37).
 - d. Connect the new tubes (72* and 42*) to the pilot valve fittings (5h) and air valve tees (40n).

Assembly

1. Apply lithium base grease to the inside and outside of the air valve (5b), and to the o-rings and seals.
2. Install the o-ring (5e*), being sure to completely seat it on the flat in the valve housing (5d). Install the long end of the valve stem (5a) into the housing.
3. Install the small spring (5g) over the valve stem (5a), the air valve (5b) over the spring, and the larger spring over the air valve.
4. With the copper gasket (5i*) in place on the valve cap (5c), screw the cap onto each of the valve housings (5d). Torque the cap to 7.4 to 12.5 ft-lb (10 to 17 N•m).

Service

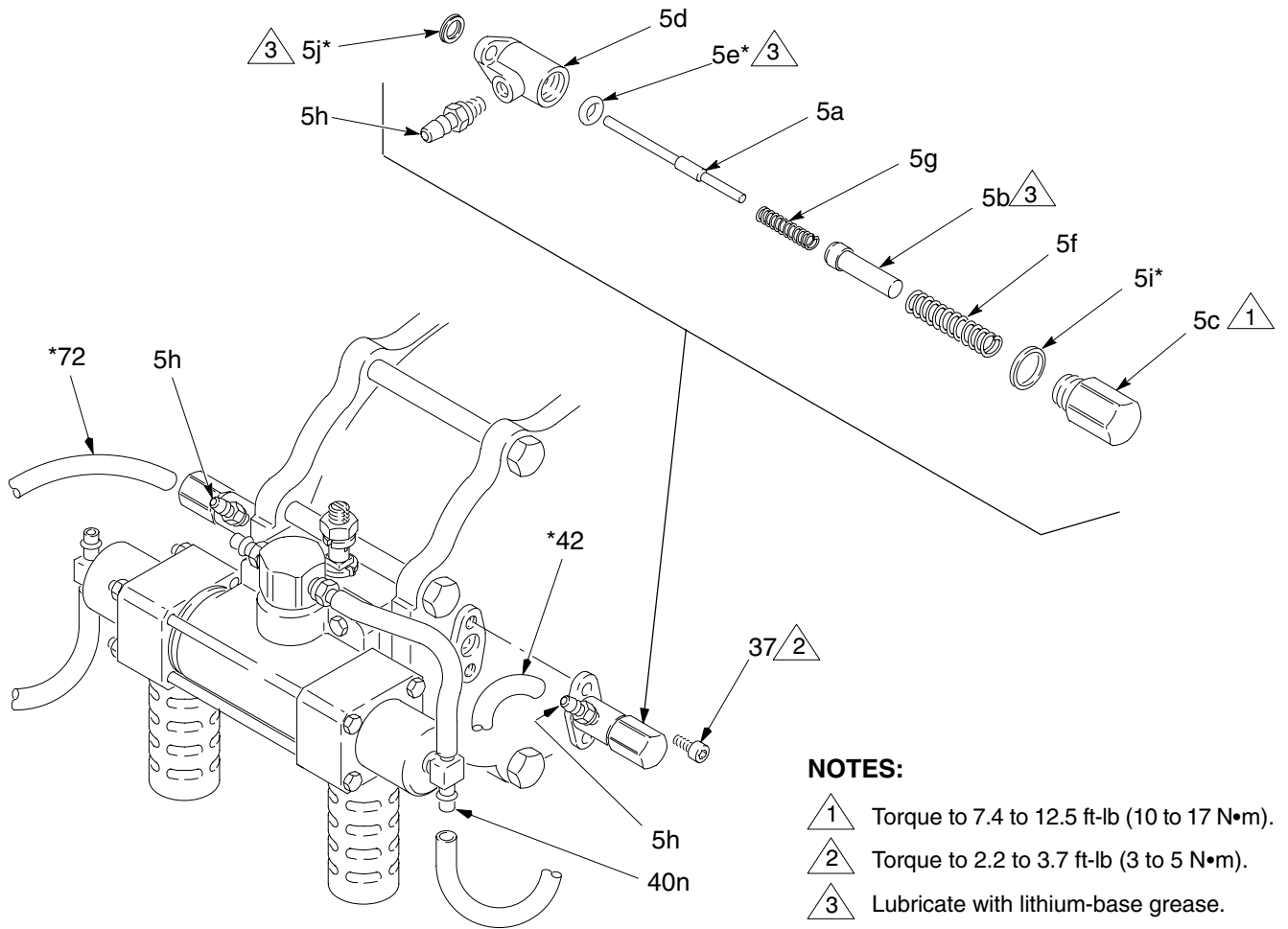

Fig. 9

02329

Parts

400 Series Carbon Steel Pumps Model 220663, Series D Model 237008, Series A

Ref. No.	Part No.	Description	Qty.	Ref. No.	Part No.	Description	Qty.
1	108712	NUT, hex; M8 x 1.25	8	28*	107160	QUAD RING; buna-N	1
2	104572	WASHER, spring lock	8	29	183355	PISTON, air motor	1
3	108786	SCREW, cap, hex hd; M8 x 1.25 x 130	2	30	183229	STUD	1
4	108711	SCREW, cap, hex hd; M8 x 1.25 x 120	6	31	181998	ACCUMULATOR	2
5	221133	PILOT VALVE ASSY See page 37 for parts	2	32	108768	SCREW, cap, hex hd; M8 x 1.25 x 16	8
12	181953	PLATE, retaining	2	33	181846	HOUSING, pump outlet	2
13*	181978	SEAL, piston; UHMW polyethylene (for pump Model 220663 only)	2	34	108654	SCREW, cap, hex hd; M12 x 1.75 x 100	8
13*	188177	SEAL, piston; Nylon (for pump Model 237008 only)	2	35	107541	WASHER, lock	8
14*	180243	SEAL, bellows; polypropylene	2	36	181847	HOUSING, pump intake	2
15	181951	SHAFT, piston	2	37	107100	SCREW, cap, hex sch; M5 x 0.8 x 12	4
16	108652	SCREW, cap, hex hd; M10 x 1.5 x 50	2	38	107189	MUFFLER	2
17	189432	PISTON, pump; 17-4 PH stainless steel	2	39	107190	RING, lock; 1/2 – 14 npt	2
18*	108824	O-RING; PTFE	2	40	220902	AIR CONTROL VALVE ASSY See page 36 for parts	1
19*	108825	O-RING; PTFE	4	42†	183384	TUBE, 0.25 in. (6.35 mm) O.D.; polyurethane	1
20	181967	PLATE, retaining; stainless steel	2	43	108787	SCREW, cap, hex hd; M5 x 0.8 x 20	4
21	108713	WIPER, shaft	2	44	181950	BRACKET, mounting	1
22	183228	BEARING	2	46	108788	WASHER, flat	10
23*	108158	U-CUP; buna-N	2	47	220486	INTAKE MANIFOLD	1
25	183098	CAP, cylinder	2	48*	103341	O-RING; PTFE	2
26*	108874	O-RING; buna-N	2	49	181947	SEAT, valve	2
27	183097	CYLINDER, air motor	1	50	220485	MANIFOLD	1
				51	108648	CONNECTOR, straight thread	2
				52*	107098	O-RING; PTFE	4
				53	181949	CAP	2
				54*	108822	O-RING; PTFE	2
				55	181976	STOP, ball; stainless steel	2
				56	181845	GUIDE, ball; stainless steel	2
				57	107167	BALL; stainless steel	2
				58	108643	PLUG, boss	2
				59	104582	WASHER, tab	1
				60	104029	LUG, grounding	1
				64	183429	LABEL, warning	1
				71	179944	LABEL, warning	1
				72†	179861	TUBE, 0.245 in. (6.35 mm) O.D.; polyurethane	1

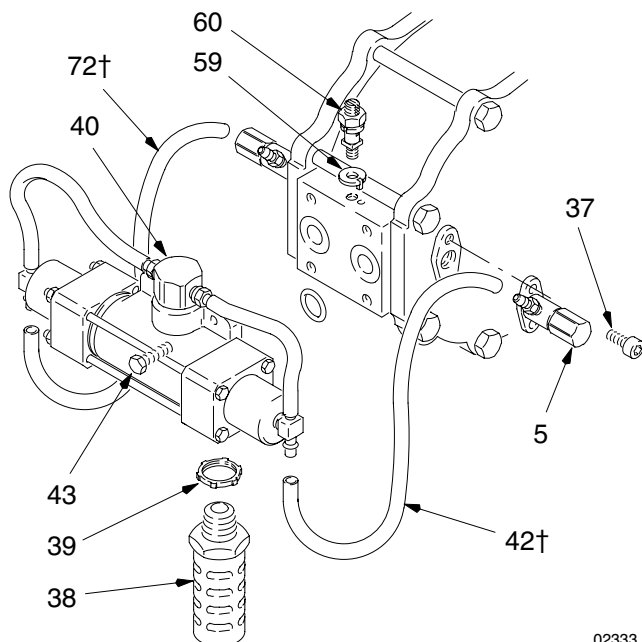

02333

* These parts are also included in Repair Kits 220949, (for pump Model 220663) and 237014 (for pump Model 237008), which may be purchased separately. The only difference between the two kits is the piston seal (Ref. No. 13).

† These parts are also included in Repair Kit 220656, which may be purchased separately.

See pages 38 and 39 for description of all Repair and Conversion Kits available.

Parts

400 Series Stainless Steel Pumps
Model 220666, Series D
Model 237011, Series A

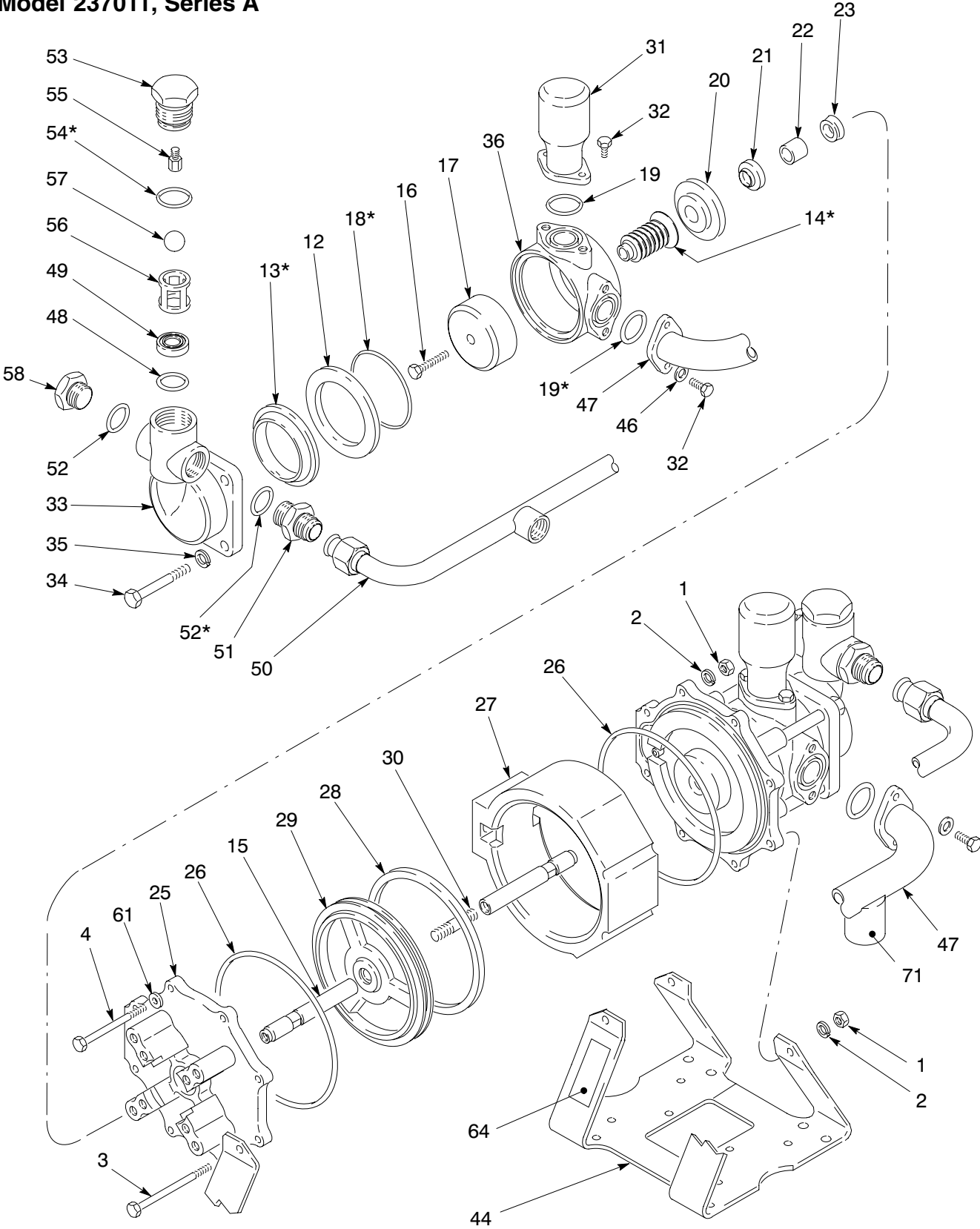

Parts

400 Series Stainless Steel Pumps Model 220666, Series D Model 237011, Series A

Ref. No.	Part No.	Description	Qty.	Ref. No.	Part No.	Description	Qty.
1	108712	NUT, hex; M8 x 1.25	8	30	183229	STUD	1
2	104572	WASHER, spring lock	8	31	220971	ACCUMULATOR	2
3	108786	SCREW, cap, hex hd; M8 x 1.25 x 130	2	32	108791	SCREW, cap, hex hd; M8 x 1.25 x 16	8
4	108711	SCREW, cap, hex hd; M8 x 1.25 x 120	6	33	181864	HOUSING, pump outlet	2
5	221133	PILOT VALVE ASSY See page 37 for parts	2	34	108793	SCREW, cap, hex hd; M12 x 1.75 x 100	8
12	181974	PLATE, retaining	2	35	111449	WASHER	8
13*	181978	SEAL, piston; UHMW polyethylene (for pump Model 220666 only)	2	36	181865	HOUSING, pump intake	2
13*	188177	SEAL, piston; Nylon (for pump Model 237011 only)	2	37	107100	SCREW, cap, hex sch; M5 x 0.8 x 12	4
14*	180243	SEAL, bellows; polypropylene	2	38	107189	MUFFLER	2
15	181951	SHAFT, piston	2	39	107190	RING, lock; 1/2 – 14 npt	2
16	108652	SCREW, cap, hex hd; M10 x 1.5 x 50	2	40	220902	AIR CONTROL VALVE ASSY See page 36 for parts	1
17	189432	PISTON, pump; 17–4 PH stainless steel	2	42†	183384	TUBE, 0.25 in. (6.35 mm) O.D.; polyurethane	1
18*	108824	O-RING; PTFE	2	43	108787	SCREW, cap, hex hd; M5 x 0.8 x 20	4
19*	108825	O-RING; PTFE	4	44	181950	BRACKET, mounting	1
20	181967	PLATE, retaining	2	46	108790	WASHER, flat	4
21	108713	WIPER, shaft	2	47	220490	INTAKE MANIFOLD	1
22	183228	BEARING	2	48*	103341	O-RING; PTFE	2
23*	108158	U-CUP; buna-N	2	49	186676	SEAT, valve	2
25	183098	CAP, cylinder	2	50	220491	OUTLET MANIFOLD	1
26*	108874	O-RING; buna-N	2	51	108647	CONNECTOR, straight thread	2
27	183097	CYLINDER, air motor	1	52*	107098	O-RING; PTFE	4
28*	107160	QUAD RING; buna-N	1	53	181969	CAP	2
29	183355	PISTON, air motor	1	54*	108822	O-RING; PTFE	2
				55	181976	STOP, ball	2
				56	181845	GUIDE, ball	2
				57	108287	BALL; stainless steel	2
				58	108644	PLUG, boss	2
				59	104582	WASHER, tab	1
				60	104029	LUG, grounding	1
				61	108788	WASHER, flat	6
				64	183429	LABEL, warning	1
				71	179944	LABEL, warning	1
				72†	179861	TUBE, 0.245 in. (6.35 mm) O.D.; polyurethane	1

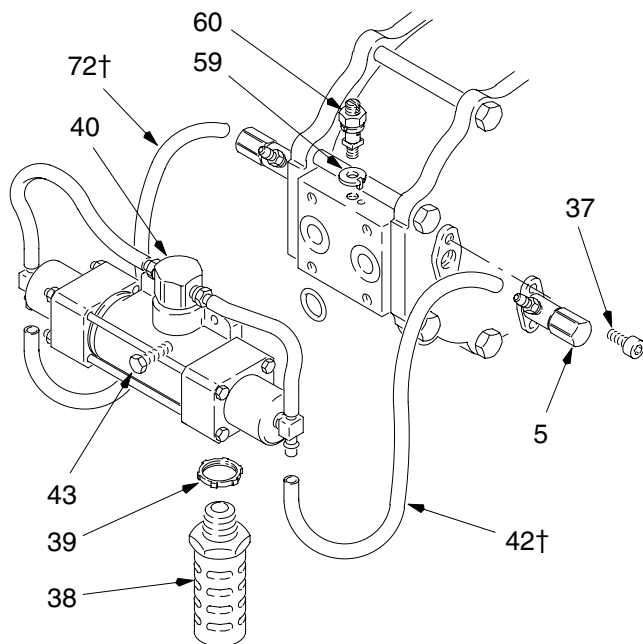

* These parts are included in Repair Kits 220949 (for pump Model 220666) and 237014 (for pump model 237011), which may be purchased separately. The only difference between the two kits is the piston seal (Ref. No. 13).

† These parts are included in Repair Kit 220656, which may be purchased separately.

See pages 38 and 39 for description of all Repair and Conversion Kits available.

Parts

1200 Series Carbon Steel Pumps
 Model 220664, Series D
 Model 237009, Series A

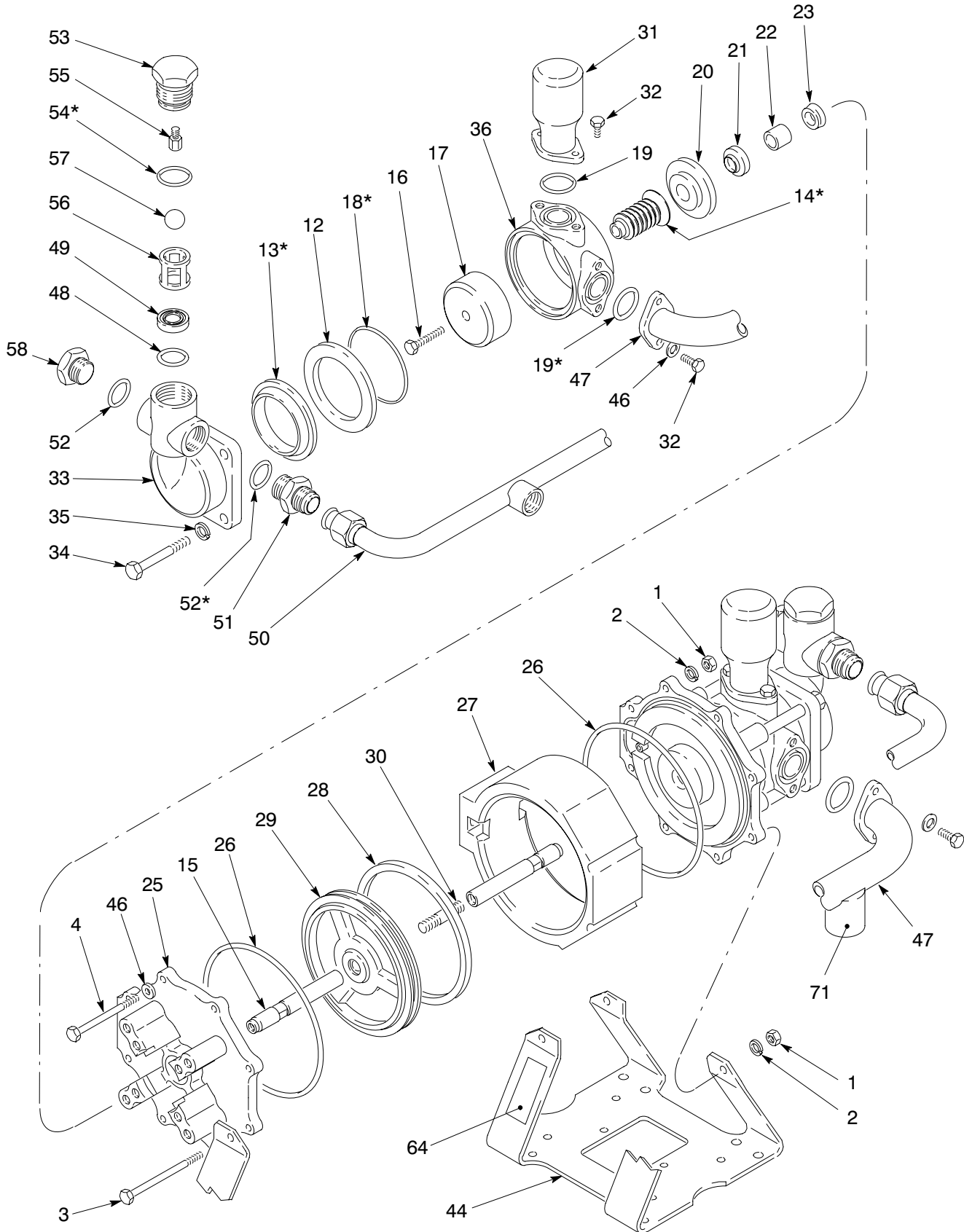

Parts

1200 Series Carbon Steel Pumps Model 220664, Series D Model 237009, Series A

Ref. No.	Part No.	Description	Qty.	Ref. No.	Part No.	Description	Qty.
1	108712	NUT, hex; M8 x 1.25	8	29	183355	PISTON, air motor	1
2	104572	WASHER, spring lock	8	30	183229	STUD	1
3	108786	SCREW, cap, hex hd; M8 x 1.25 x 130	2	31	181998	ACCUMULATOR	2
4	108711	SCREW, cap, hex hd; M8 x 1.25 x 120	6	32	108768	SCREW, cap, hex hd; M8 x 1.25 x 16	8
5	221133	PILOT VALVE ASSY See page 37 for parts	2	33	181854	HOUSING, pump outlet	2
12	181975	PLATE, Retaining	2	34	108654	SCREW, cap, hex hd; M12 x 1.75 100	8
13*	183240	SEAL, piston; UHMW polyethylene (for pump Model 220664 only)	2	35	107541	WASHER, lock	8
13*	188178	SEAL, piston; Nylon (for pump Model 237009 only)	2	36	181847	HOUSING, pump intake	2
14*	180243	SEAL, bellows; polypropylene	2	37	107100	SCREW, cap, hex sch; M5 x 0.8 x 12	4
15	181951	SHAFT, piston	2	38	107189	MUFFLER	2
16	108652	SCREW, cap, hex hd; M10 x 1.5 x 50	2	39	107190	RING, lock; 1/2 – 14 npt	2
17	189433	PISTON, pump; 17–4 PH stainless steel	2	40	220902	AIR CONTROL VALVE ASSY See page 36 for parts	1
18*	108824	O-RING; PTFE	2	42†	183384	TUBE, 0.25 in. (6.35 mm) O.D.; polyurethane	1
19*	108825	O-RING; PTFE	4	43	108787	SCREW, cap, hex hd; M5 x 0.8 x 20	4
20	181967	PLATE, retaining; stainless steel	2	44	181950	BRACKET, mounting	1
21	108713	WIPER, shaft	2	46	108788	WASHER, flat	10
22	183228	BEARING	2	47	220486	INTAKE MANIFOLD	1
23*	108158	U-CUP; buna-N	2	48*	103341	O-RING; PTFE	2
25	183098	CAP, cylinder	2	49	181947	SEAT, valve	2
26*	108874	O-RING; buna-N	2	50	220485	OUTLET MANIFOLD	1
27	183097	CYLINDER, air motor	1	51	108648	CONNECTOR, straight thread	2
28*	107160	QUAD RING; buna-N	1	52*	107098	O-RING; PTFE	4
				53	181949	CAP	2
				54*	108822	O-RING; PTFE	2
				55	181976	STOP, ball; stainless steel	2
				56	181845	GUIDE, ball; stainless steel	2
				57	107167	BALL; stainless steel	2
				58	108643	PLUG, boss	2
				59	104582	WASHER, tab	1
				60	104029	LUG, grounding	1
				64	183429	LABEL, warning	1
				71	179944	LABEL, warning	1
				72†	179861	TUBE, 0.245 in. (6.35 mm) O.D.; polyurethane	1

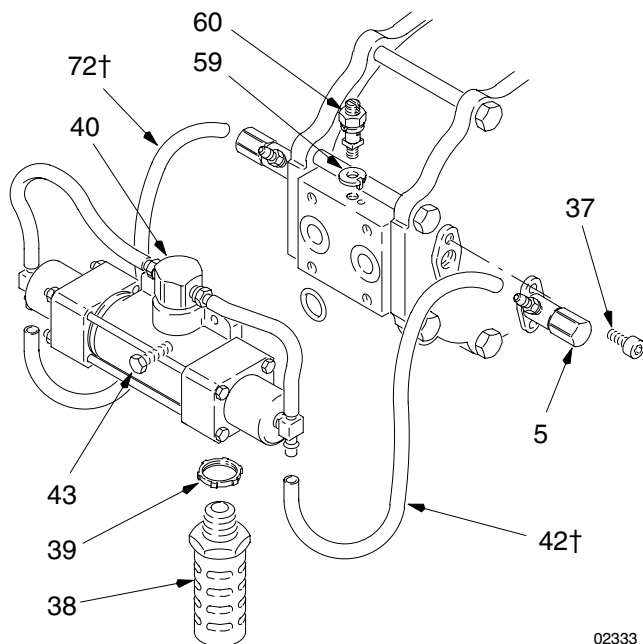

* These parts are included in Repair Kits 221136 (for pump Model 220664) and 237017 (for pump Model 237009), which may be purchased separately. The only difference is the piston seal (Ref. No. 13).

† These parts are included in Repair Kit 220656, which may be purchased separately.

02333

See pages 38 and 39 for description of all Repair and Conversion Kits available.

Parts

1200 Series Stainless Steel Pumps
 Model 220667, Series D
 Model 237012, Series A

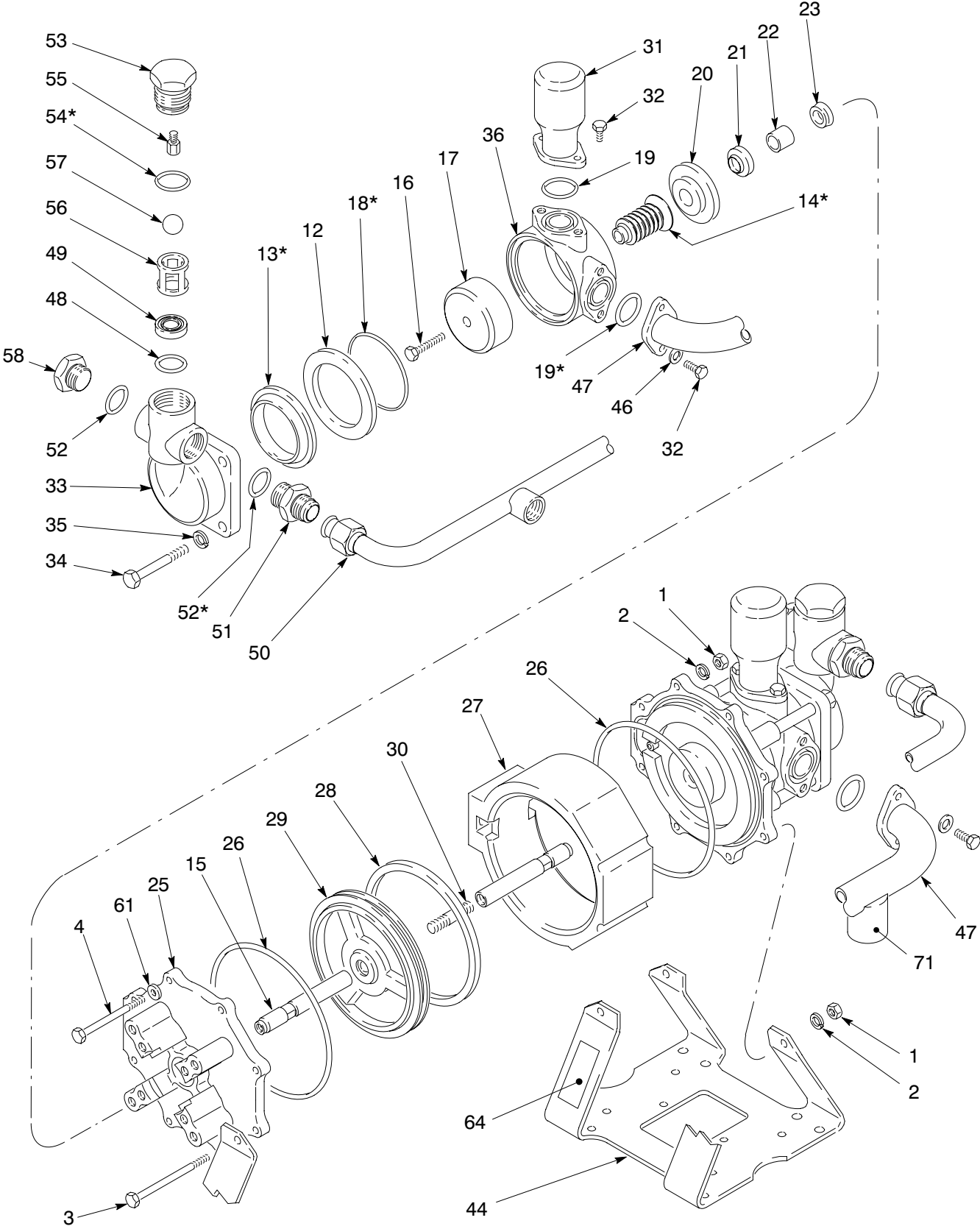

Parts

1200 Series Stainless Steel Pumps

Model 220667, Series D

Model 237012, Series A

Ref.

No.	Part No.	Description	Qty.	Ref. No.	Part No.	Description	Qty.
1	108712	NUT, hex; M8 x 1.25	8	30	183229	STUD	1
2	104572	WASHER, spring lock	8	31	220971	ACCUMULATOR	2
3	108786	SCREW, cap, hex hd; M8 x 1.25 x 130	2	32	108791	SCREW, cap, hex hd; M8 x 1.25 x 16	8
4	108711	SCREW, cap, hex hd; M8 x 1.25 x 120	6	33	181866	HOUSING, pump outlet	2
5	221133	PILOT VALVE ASSY See page 37 for parts	2	34	108793	SCREW, cap, hex hd; M12 x 1.75 100	8
12	181973	PLATE, retaining	2	35	111449	WASHER	8
13*	183240	SEAL, piston; UHMW polyethylene (for pump Model 220667 only)	2	36	181865	HOUSING, pump intake	2
13*	188178	SEAL, piston; Nylon (for pump Model 237012 only)	2	37	107100	SCREW, cap, hex sch; M5 x 0.8 x 12	4
14*	180243	SEAL, bellows; polypropylene	2	38	107189	MUFFLER	2
15	181951	SHAFT, piston	2	39	107190	RING, lock; 1/2 – 14 npt	2
16	108652	SCREW, cap, hex hd; M10 x 1.5 x 50	2	40	220902	AIR CONTROL VALVE ASSY See page 36 for parts	1
17	189433	PISTON, pump; 17–4 PH stainless steel	2	42†	183384	TUBE, 0.25 in. (6.35 mm) O.D.; polyurethane	1
18*	108824	O-RING; PTFE	2	43	108787	SCREW, cap, hex hd; M5 x 0.8 x 20	4
19*	108825*	O-RING; PTFE	4	44	181950	BRACKET, mounting	1
20	181967	PLATE, retaining	2	46	108790	WASHER, flat	6
21	108713	WIPER, shaft	2	47	220490	INTAKE MANIFOLD	1
22	183228	BEARING	2	48*	103341	O-RING; PTFE	2
23*	108158	U-CUP; buna-N	2	49	220948	SEAT, valve	2
25	183098	CAP, cylinder	2	50	220491	OUTLET MANIFOLD	1
26*	108874	O-RING; buna-N	2	51	108647	CONNECTOR, straight thread	2
27	183097	CYLINDER, air motor	1	52*	107098	O-RING; PTFE	4
28*	107160	QUAD RING; buna-N	1	53	181969	CAP	2
29	183355	PISTON, air motor	1	54*	108822	O-RING; PTFE	2
				55	181976	STOP, ball	2
				56	181845	GUIDE, ball	2
				57	108287	BALL; stainless steel	2
				58	108644	PLUG, boss	2
				59	104582	WASHER, tab	1
				60	104029	LUG, grounding	1
				61	108788	WASHER, flat	4
				64	183429	LABEL, warning	1
				71	179944	LABEL, warning	1
				72†	179861	TUBE, 0.245 in. (6.35 mm) O.D.; polyurethane	1

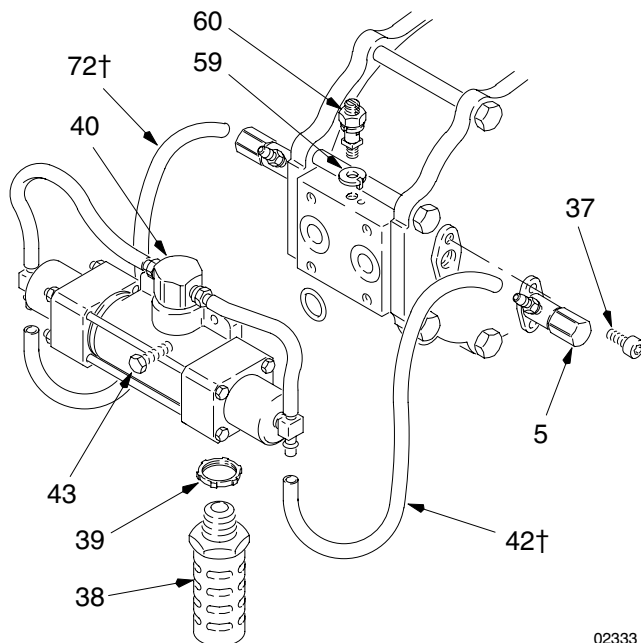

* These parts are included in Repair Kits 221136 (for pump Model 220667) and 237017 (for pump Model 237012), which may be purchased separately. The only difference between the two kits is the piston seal (Ref. No. 13).

† These parts are included in Repair Kit 220656, which may be purchased separately.

02333

See pages 38 and 39 for description of all Repair and Conversion Kits available.

Parts

2500 Series Carbon Steel Pumps
Model 220665, Series D
Model 237010, Series A

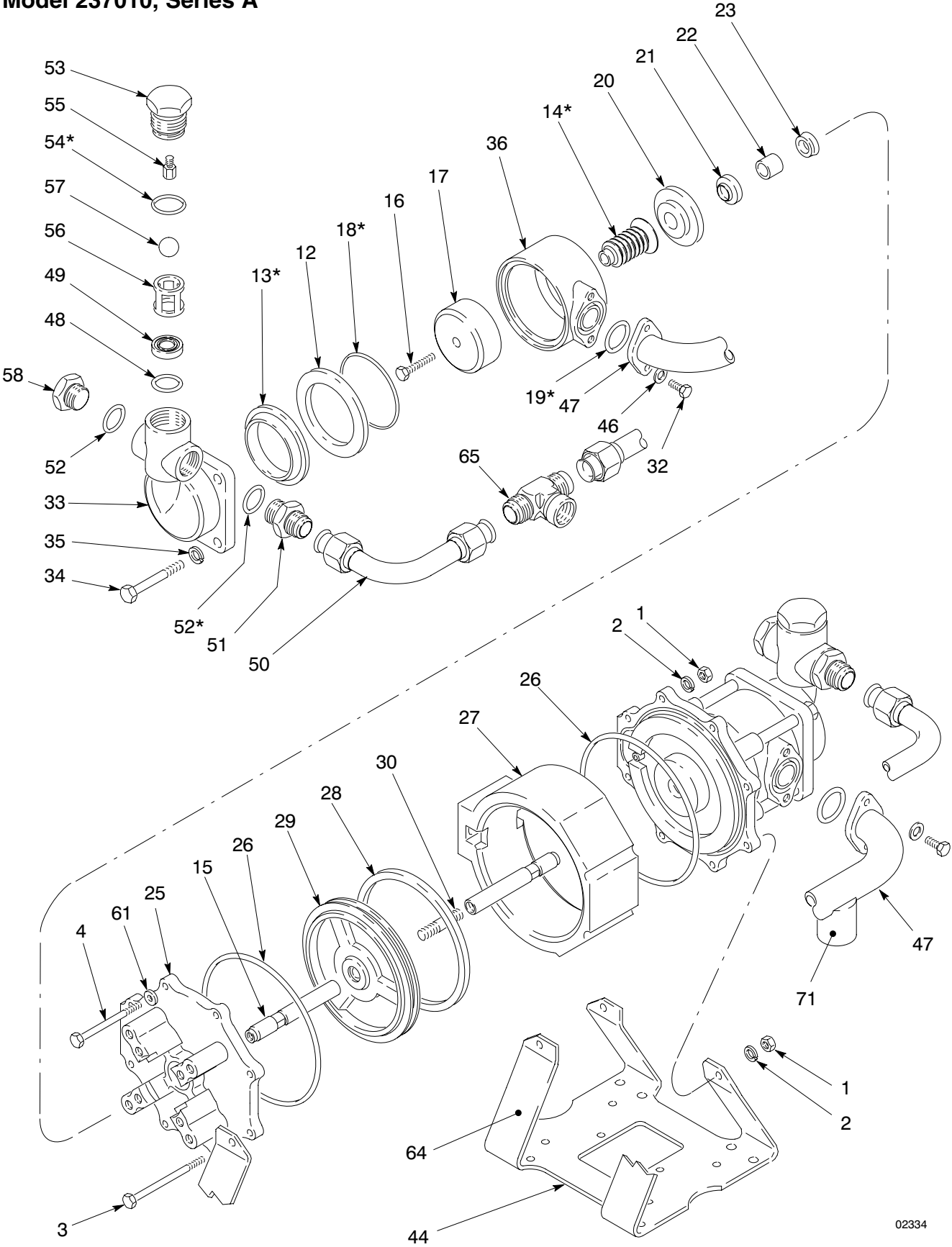

02334

Parts

2500 Series Carbon Steel Pumps Model 220665, Series D Model 237010, Series A

Ref. No.	Part No.	Description	Qty.	Ref. No.	Part No.	Description	Qty.
1	108712	NUT, hex; M8 x 1.25	8	29	183355	PISTON, air motor	1
2	104572	WASHER, spring lock	8	30	183229	STUD	1
3	108786	SCREW, cap, hex hd; M8 x 1.25 x 130	2	32	108768	SCREW, cap, hex hd; M8 x 1.25 x 16	4
4	108711	SCREW, cap, hex hd; M8 x 1.25 x 120	6	33	181853	HOUSING, pump outlet	2
5	221133	PILOT VALVE ASSY See page 37 for parts	2	34	108655	SCREW, cap, hex hd; M10 x 1.5 x 100	8
12	181958	PLATE, retaining	2	35	108770	WASHER, lock	8
13*	181959	SEAL, piston; UHMW polyethylene (for pump Model 220665 only)	2	36	181856	HOUSING, pump intake	2
13*	188176	SEAL, piston; Nylon (for pump Model 237010 only)	2	37	107100	SCREW, cap, hex sch; M5 x 0.8 x 12	4
14*	180243	SEAL, bellows; polypropylene	2	38	107189	MUFFLER	2
15	181951	SHAFT, piston	2	39	107190	RING, lock; 1/2 – 14 npt	2
16	108652	SCREW, cap, hex hd; M10 x 1.5 x 50	2	40	220902	AIR CONTROL VALVE ASSY See page 36 for parts	1
17	189434	PISTON, pump; 17–4 PH stainless steel	2	42†	183384	TUBE, 0.25 in. (6.35 mm) O.D.; polyurethane	1
18*	108823	O-RING; PTFE	2	43	108787	SCREW, cap, hex hd; M5 x 0.8 x 20	4
19*	108825	O-RING; PTFE	2	44	181950	BRACKET, mounting	1
20	181967	PLATE, retaining; stainless steel	2	46	108788	WASHER, flat	10
21	108713	WIPER, shaft	2	47	220486	INTAKE MANIFOLD	1
22	183228	BEARING	2	48*	107313	O-RING; PTFE	2
23*	108158	U-CUP; buna-N	2	49	189067	SEAT, valve	2
25	183098	CAP, cylinder	2	50	220487	OUTLET MANIFOLD	2
26*	108874	O-RING; buna-N	2	51	108646	CONNECTOR, straight thread	2
27	183097	CYLINDER, air motor	1	52*	108526	O-RING; PTFE	4
28*	107160	QUAD RING; buna-N	1	53	181949	CAP	2
				54*	108822	O-RING; PTFE	2
				55	185552	STOP, ball; stainless steel	2
				56	181852	GUIDE, ball; stainless steel	2
				57	101822	BALL; stainless steel	2
				58	108642	PLUG, boss	2
				59	104582	WASHER, tab	1
				60	104029	LUG, grounding	1
				64	183429	LABEL, warning	1
				65	108869	TEE, outlet, female	1
				71	179944	LABEL, warning	1
				72†	179861	TUBE, 0.245 in. (6.35 mm) O.D.; polyurethane	1

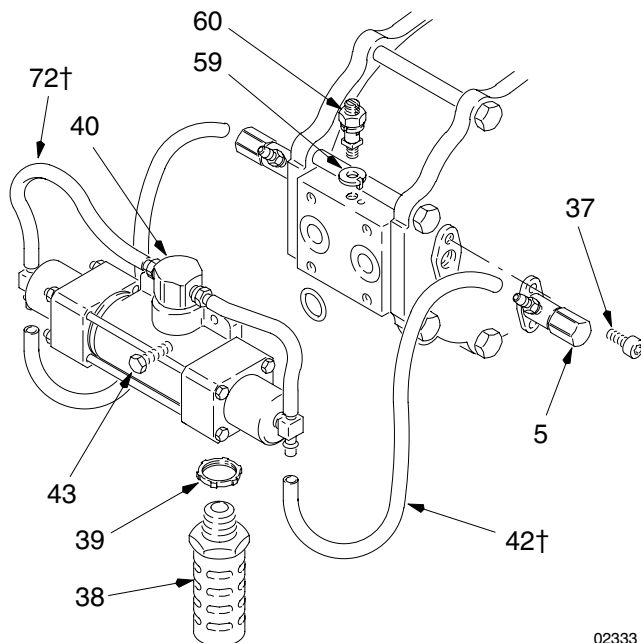

* Included in Repair KitS 220950 (for pump Model 220665) and 237016 (for pump Model 237010, which may be purchased separately. The only difference between the two kits is the piston seal (Ref No. 13).

† Included in Repair Kit 220656, which may be purchased separately.

02333

See pages 38 and 39 for description of all Repair and Conversion Kits available.

Parts

2500 Series Stainless Steel Pumps
 Model 220668, Series D
 Model 237013, Series A

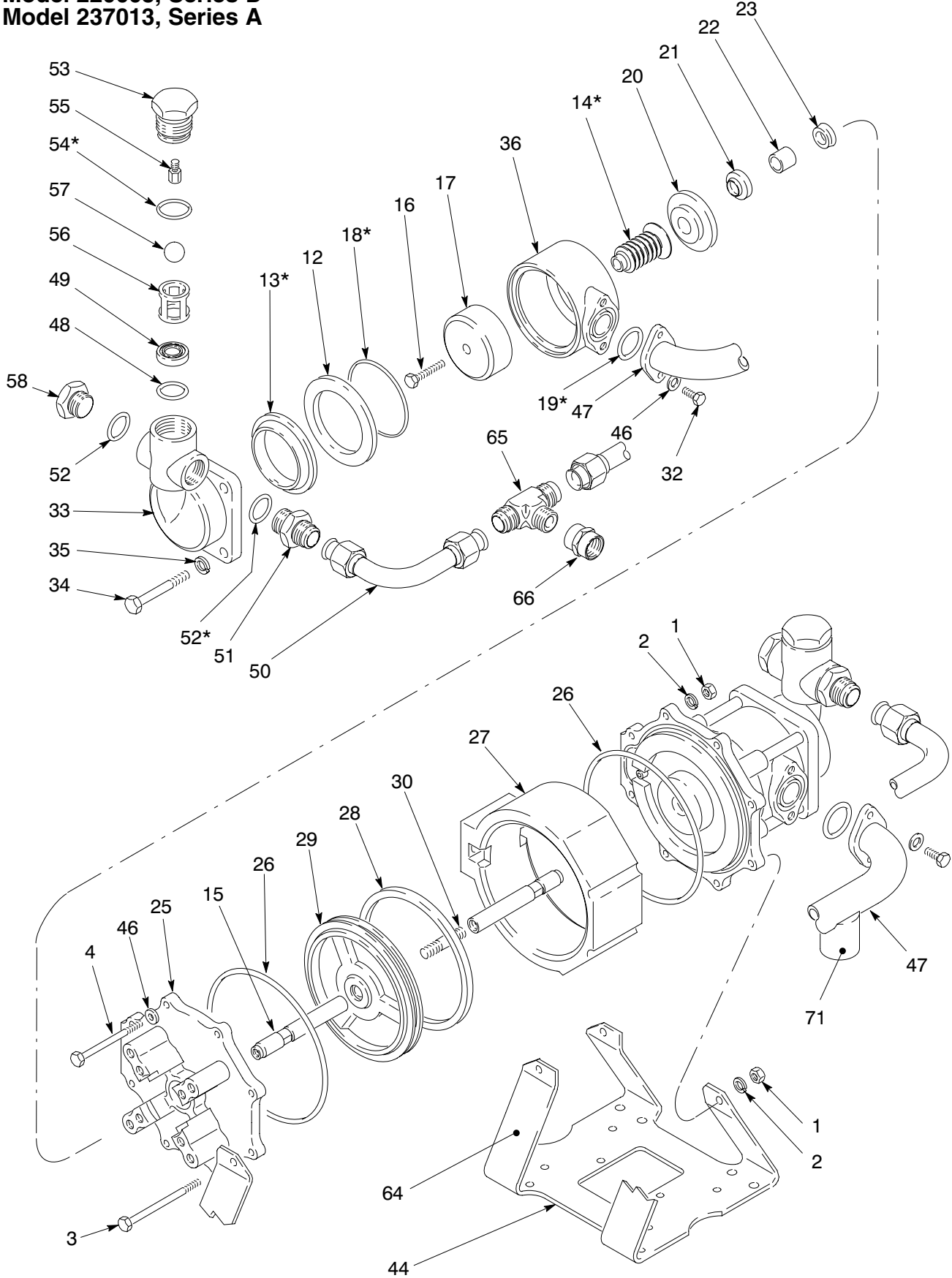

Parts

2500 Series Stainless Steel Pumps Model 220668, Series D Model 237013, Series A

Ref. No.	Part No.	Description	Qty.	Ref. No.	Part No.	Description	Qty.
1	108712	NUT, hex; M8 x 1.25	8	32	108791	SCREW, cap, hex hd; M8 x 1.25 x 16	4
2	104572	WASHER, spring lock	8	33	185554	HOUSING, pump outlet	2
3	108786	SCREW, cap, hex hd; M8 x 1.25 x 130	2	34	110622	SCREW, cap, hex hd; M10 x 1.5 x 100	8
4	108711	SCREW, cap, hex hd; M8 x 1.25 x 120	6	35	110621	WASHER, lock	8
5	221133	PILOT VALVE ASSY See page 37 for parts	2	36	185555	HOUSING, pump intake	2
12	185940	PLATE, retaining	2	37	107100	SCREW, cap, hex sch; M5 x 0.8 x 12	4
13*	181959	SEAL, piston; UHMW polyethylene (for pump Model 220668 only)	2	38	107189	MUFFLER	2
13*	188176	SEAL, piston; Nylon (for pump Model 237013 only)	2	39	107190	RING, lock; 1/2 – 14 npt	2
14*	180243	SEAL, bellows; polypropylene	2	40	220902	AIR CONTROL VALVE ASSY See page 36 for parts	1
15	181951	SHAFT, piston	2	41	108790	WASHER, Flat	4
16	108652	SCREW, cap, hex hd; M10 x 1.5 x 50	2	42†	183384	TUBE, 0.25 in. (6.35 mm) O.D.; polyurethane	1
17	189434	PISTON, pump; 17–4 PH stainless steel	2	43	108787	SCREW, cap, hex hd; M5 x 0.8 x 20	4
18*	108823	O-RING; PTFE	2	44	181950	BRACKET, mounting	1
19*	108825	O-RING; PTFE	2	46	108788	WASHER, flat	6
20	181967	PLATE, retaining; stainless steel	2	47	220490	INTAKE MANIFOLD	1
21	108713	WIPER, shaft	2	48*	107313	O-RING; PTFE	2
22	183228	BEARING	2	49	189067	SEAT, valve	2
23*	108158	U-CUP; buna-N	2	50	223111	OUTLET MANIFOLD	2
25	183098	CAP, cylinder	2	51	185553	CONNECTOR, straight thread	2
26*	108874	O-RING; buna-N	2	52*	108526	O-RING; PTFE	4
27	183097	CYLINDER, air motor	1	53	181969	CAP	2
28*	107160	QUAD RING; buna-N	1	54*	108822	O-RING; PTFE	2
29	183355	PISTON, air motor	1	55	185552	STOP, ball	2
30	183229	STUD	1	56	181852	GUIDE, ball; stainless steel	2
				57	101822	BALL; stainless steel	2
				58	185941	PLUG, boss	2
				59	104582	WASHER, Tab	1
				60	104029	LUG, grounding	1
				64	183429	LABEL, warning	1
				65	110315	TEE, outlet, male; stainless steel	1
				66	112176	COUPLING, female, 3/4 npt; stainless steel	1
				71	179944	LABEL, warning	1
				72†	179861	TUBE, 0.245 in. (6.35 mm) O.D.; polyurethane	1

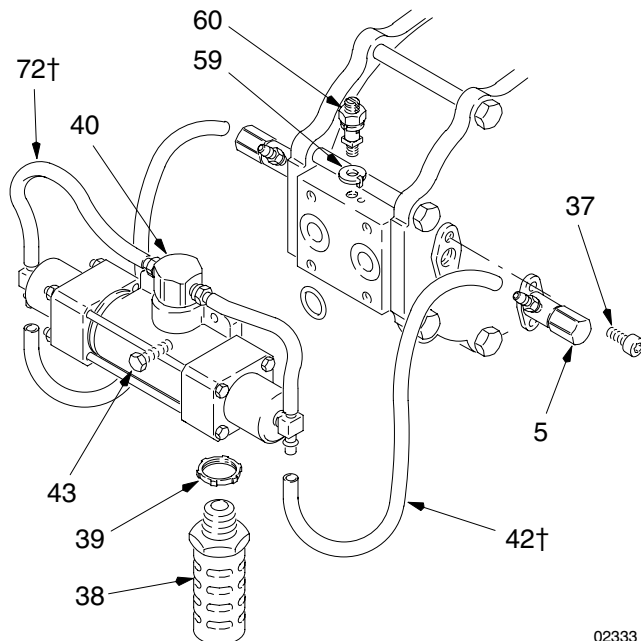

* These parts are included in Repair Kits 220950 (for pump Model 220668) and 237016 (for pump Model 237013), which may be purchased separately. The only difference between the two kits is the piston seal (Ref. No. 13).

† These parts are included in Repair Kit 220656, which may be purchased separately.

See pages 38 and 39 for description of all Repair and Conversion Kits available.

Parts

Ref No. 40 Air Control Valve 220902

NOTE: This assembly is included with all pump models.

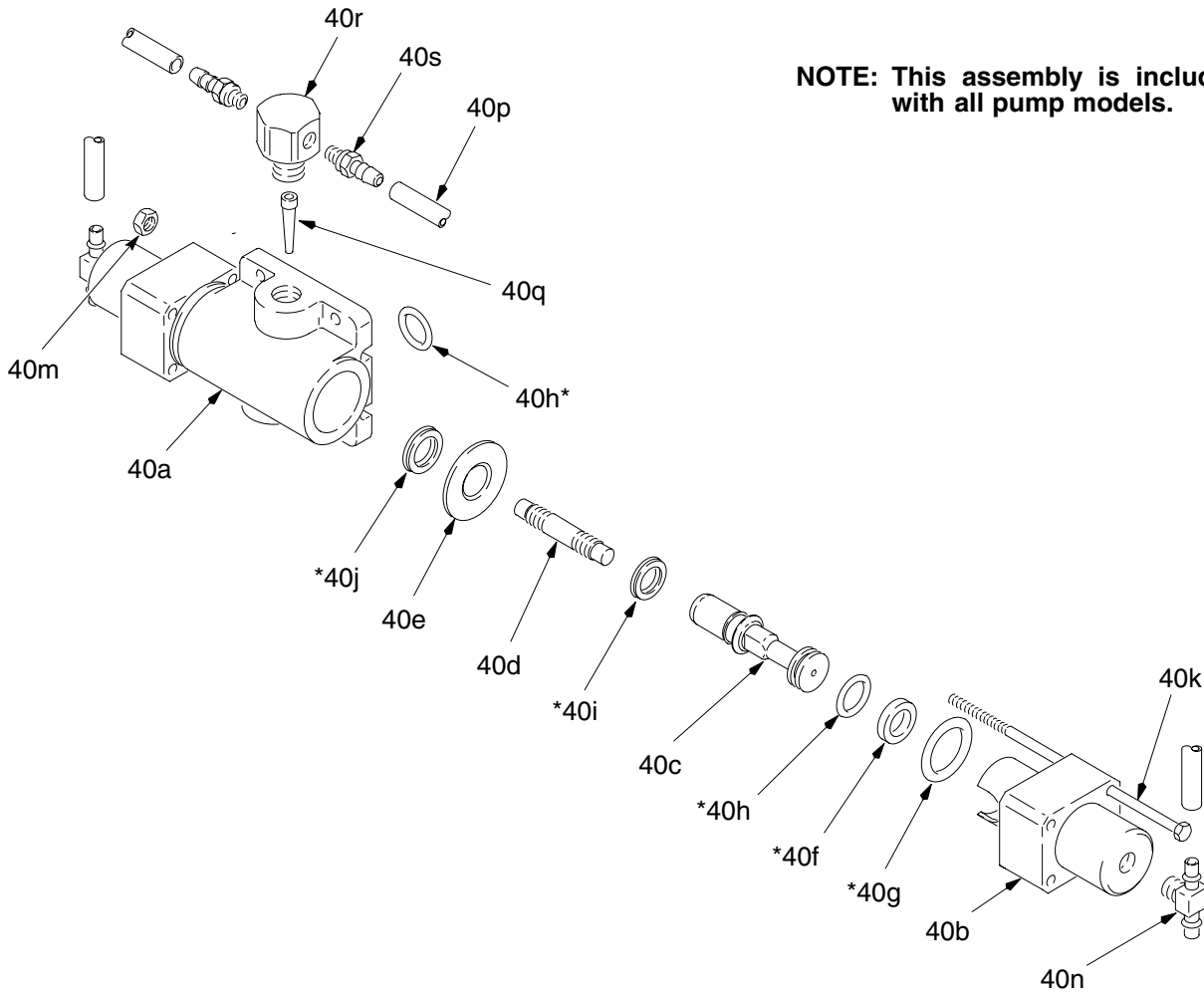

02330

Ref. No.	Part No.	Description	Qty.	Ref. No.	Part No.	Description	Qty.
40a	183370	HOUSING, valve center	1	40k	108780	SCREW, cap, hex hd; M5 x 0.8 x 150	4
40b	183369	HOUSING, valve end	2	40m	100179	NUT, full hex; 10–24 UNC–2A	4
40c	183368	SPOOL, differential	2	40n	107191	TEE, barbed	2
40d	183367	STEM, spool	1	40p*	179861	TUBE, polyurethane; 0.25 in. (6.35 mm) O.D.	2
40e	183366	RETAINER, seal	2	40q	160736	FILTER, air	1
40f *	181464	GASKET, polyurethane	2	40r	183620	HOUSING, air filter	1
40g*	105400	O-RING, buna-N	2	40s	108383	FITTING, barbed, with buna-N o-ring	2
40h*	107186	O-RING, buna-N	4				
40i*	108781	U-CUP, polyurethane	2				
40j*	108782	U-CUP, polyurethane	2				

* These parts are included in Repair Kit 220656. See pages 38 and 39 for description of all Repair and Conversion Kits available.

Parts

Ref No. 5 Pilot Valve 221133

NOTE: This assembly is included with all pump models.

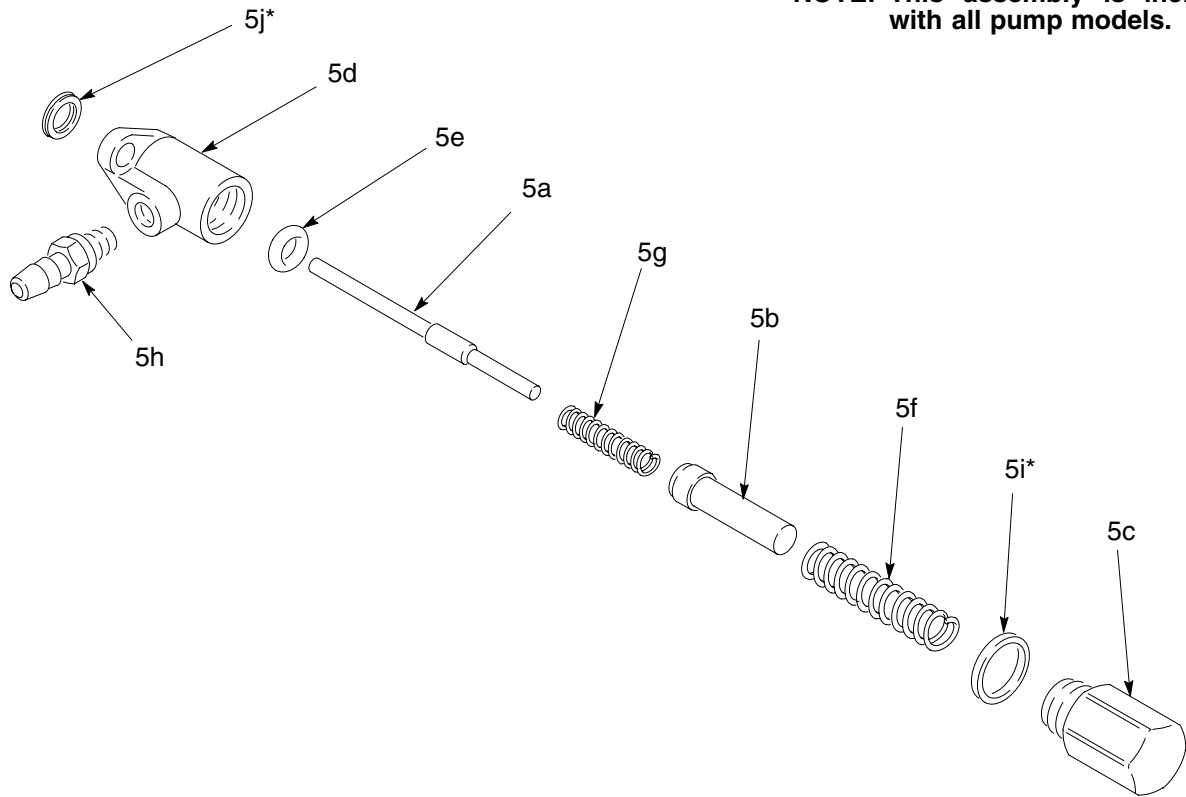

02331

Ref. No.	Part No.	Description	Qty.	Ref. No.	Part No.	Description	Qty.
5a	183604	STEM, valve	1	5h	108383	FITTING, barbed, buna-N o-ring seal; 10-32 UNF-2A	1
5b	183603	VALVE, air	1	5i*	156766	GASKET, copper	2
5c	183605	CAP, valve	1	5j*	107161	SEAL, pilot valve rod, buna-N	2
5d	183606	HOUSING, valve	2				
5e*	159589	O-RING, buna-N	1				
5f	108961	SPRING, compression	1				
5g	108960	SPRING, compression	1				

* These parts are included in Repair Kit 220656. See pages 38 and 39 for description of all Repair and Conversion Kits available.

Repair and Conversion Kits

The reference numbers shown in the kits below correspond to the reference numbers used in the parts lists and drawings on pages 24 to 37. Use all the kit parts, even if the old parts still look good.

Air Valve and Pilot Valve Repair Kit 220656

Ref. No.	Part No.	Description	Qty.
5j	107161	SEAL, pilot valve rod, buna-N	2
5i	156766	GASKET, copper	2
5e	159589	O-RING, buna-N	2
40f	181464	GASKET, polyurethane	2
40g	110782	O-RING, buna-N	2
40h	107186	O-RING, buna-N	4
40i	108781	U-CUP, polyurethane	2
40j	108782	U-CUP, polyurethane	2
40p	179861	TUBE, polyurethane, 0.25 in. OD	3
42	183384	TUBE, polyurethane, 0.217 in. ID	1
	108754	SEALANT, anaerobic, medium strength, 0.5 cc tube	1

400 Series Pump Urethane Piston Seal Conversion Kit 220658

Ref. No.	Part No.	Description	Qty.
13	181954	SEAL, piston, urethane	2
18	108824	O-RING, PTFE	2
19	108825	O-RING, PTFE	4
48	103341	O-RING, PTFE	2
52	107098	O-RING, PTFE	4
54	108822	O-RING, PTFE	2

400 Series Pump Repair Kit 220949 (for pump Model 220663 and 220666)

Ref. No.	Part No.	Description	Qty.
13	181978	SEAL, piston; UHMWPE	2
14	180243	SEAL, bellows, polypropylene	2
18	108824	O-RING, PTFE	2
19	108825	O-RING, PTFE	4
23	108158	U-CUP, buna-N	2
26	108874	O-RING, buna-N	2
28	107160	QUAD RING, buna-N	1
48	103341	O-RING, PTFE	2
52	107098	O-RING, PTFE	4
54	108822	O-RING, PTFE	2

400 Series Pump Repair Kit 237014 (for pump Model 237008 and 237011)

Ref. No.	Part No.	Description	Qty.
13	188177	SEAL, piston; Nylon	2
14	180243	SEAL, bellows, polypropylene	2
18	108824	O-RING, PTFE	2
19	108825	O-RING, PTFE	4
23	108158	U-CUP, buna-N	2
26	108874	O-RING, buna-N	2
28	107160	QUAD RING, buna-N	1
48	103341	O-RING, PTFE	2
52	107098	O-RING, PTFE	4
54	108822	O-RING, PTFE	2

400 and 1200 Series Pumps Carbide Ball and Seat Conversion Kit 221134

Ref. No.	Part No.	Description	Qty.
48	103341	O-RING, PTFE	2
49	220948	SEAT, carbide	2
54	108822	O-RING, PTFE	2
57	108286	BALL, bearing, carbide	2

Repair and Conversion Kits

The reference numbers shown in the kits below correspond to the reference numbers used in the parts lists and drawings on pages 24 to 37. Use all the kit parts, even if the old parts still look good.

1200 Series Pump Repair Kit 221136 (for pump Models 220664 and 220667)

Ref. No.	Part No.	Description	Qty.
13	183240	SEAL, piston; UHMWPE	2
14	180243	SEAL, bellows, polypropylene	2
18	108824	O-RING, PTFE	2
19	108825	O-RING, PTFE	4
23	108158	U-CUP, buna-N	2
26	108874	O-RING, buna-N	2
28	107160	QUAD RING, buna-N	1
48	103341	O-RING, PTFE	2
52	107098	O-RING, PTFE	4
54	108822	O-RING, PTFE	2

1200 Series Pump Repair Kit 237017 (for pump Models 237009 and 237012)

Ref. No.	Part No.	Description	Qty.
13	188178	SEAL, piston; Nylon	2
14	180243	SEAL, bellows, polypropylene	2
18	108824	O-RING, PTFE	2
19	108825	O-RING, PTFE	4
23	108158	U-CUP, buna-N	2
26	108874	O-RING, buna-N	2
28	107160	QUAD RING, buna-N	1
48	103341	O-RING, PTFE	2
52	107098	O-RING, PTFE	4
54	108822	O-RING, PTFE	2

2500 Series Pump Urethane Piston Seal Conversion Kit 220660

Ref. No.	Part No.	Description	Qty.
13	181964	SEAL, piston, urethane	2
18	108823	O-RING, PTFE	2
19	108825	O-RING, PTFE	2
48	107313	O-RING, PTFE	2
52	108526	O-RING, PTFE	4
54	108822	O-RING, PTFE	2

2500 Series Pump Carbide Ball and Seat Conversion Kit 221135

Ref. No.	Part No.	Description	Qty.
48	107313	O-RING, PTFE	2
49	220947	SEAT, carbide	2
54	108822	O-RING, PTFE	2
57	108818	BALL, bearing, carbide	2

2500 Series Pump Repair Kit 220950 (for pump Models 220665 and 220668)

Ref. No.	Part No.	Description	Qty.
13	181959	SEAL, piston; UHMWPE	2
14	180243	SEAL, bellows, polypropylene	2
18	108823	O-RING, PTFE	2
19	108825	O-RING, PTFE	2
23	108158	U-CUP, buna-N	2
26	108874	O-RING, buna-N	2
28	107160	QUAD RING, buna-N	1
48	107313	O-RING, PTFE	2
52	108526	O-RING, PTFE	4
54	108822	O-RING, PTFE	2

2500 Series Pump Repair Kit 237016 (for pump Models 237010 and 237013)

Ref. No.	Part No.	Description	Qty.
13	188176	SEAL, piston; Nylon	2
14	180243	SEAL, bellows, polypropylene	2
18	108823	O-RING, PTFE	2
19	108825	O-RING, PTFE	2
23	108158	U-CUP, buna-N	2
26	108874	O-RING, buna-N	2
28	107160	QUAD RING, buna-N	1
48	107313	O-RING, PTFE	2
52	108526	O-RING, PTFE	4
54	108822	O-RING, PTFE	2

Filter, Regulator, Lubricator Kit

Filter, Regulator, Lubricator (FRL) Kit 222345

FRL Kit 222345 (shown below) is available for Glutton pumps.

Ref. No.	Part No.	Description	Qty.	Ref. No.	Part No.	Description	Qty.
	223004	Filter, Regulator Lubricator Assy Includes items 1 to 7	1	8	101689	GAUGE, Air Pressure	1
1	106149	. Air Line Filter	1	9	183746	Bracket	1
2	104266	. Air Regulator	1	10	183747	Bracket	1
3	214848	. Lubricator	1	11	100119	ELBOW, street	1
4		. Nipple	2	12	107142	VALVE, ball	1
5	106145	. Bracket (not shown as not used with this pump)	2	13	218093	HOSE, coupled	1
6		. U-Bolt	2	14	155470	UNION, swivel, 90°	1
7		. Nut	4	15	222297	UNION, swivel, 45°	1

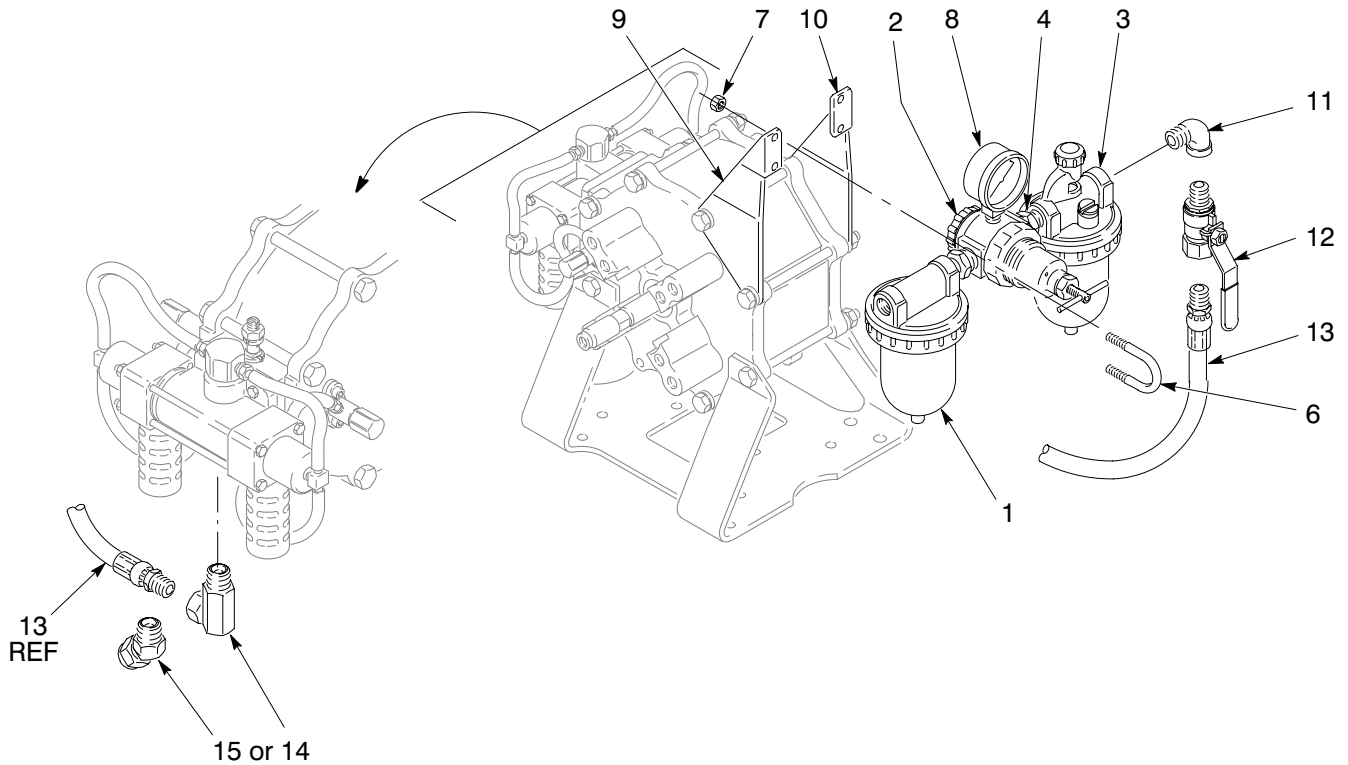

02335

Drum Cover Kit and Return Tube Kit

Drum Cover Kit 222655

Drum Cover Kit 222655 (shown below with a Glutton pump) is available.

Return Tube Kit 223319

Return Tube Kit 223319 (shown below) is available.

Ref.

Ref. No.	Part No.	Description	Qty.
1	185392	TUBE, suction, SST	1
2	237949	DRUM COVER ASSY <i>See manual 308466 for parts..</i>	1
3	222698	AGITATOR, air driven, SST Refer to Manual 306840 for parts	1
4	207438	UNION, swivel, 90°	1

Ref. No.	Part No.	Description	Qty.
101	108761	ELBOW	1
102	185394	ADAPTER, return	1
103	178941	NUT, hex retaining	1
104	185393	TUBE, return	1

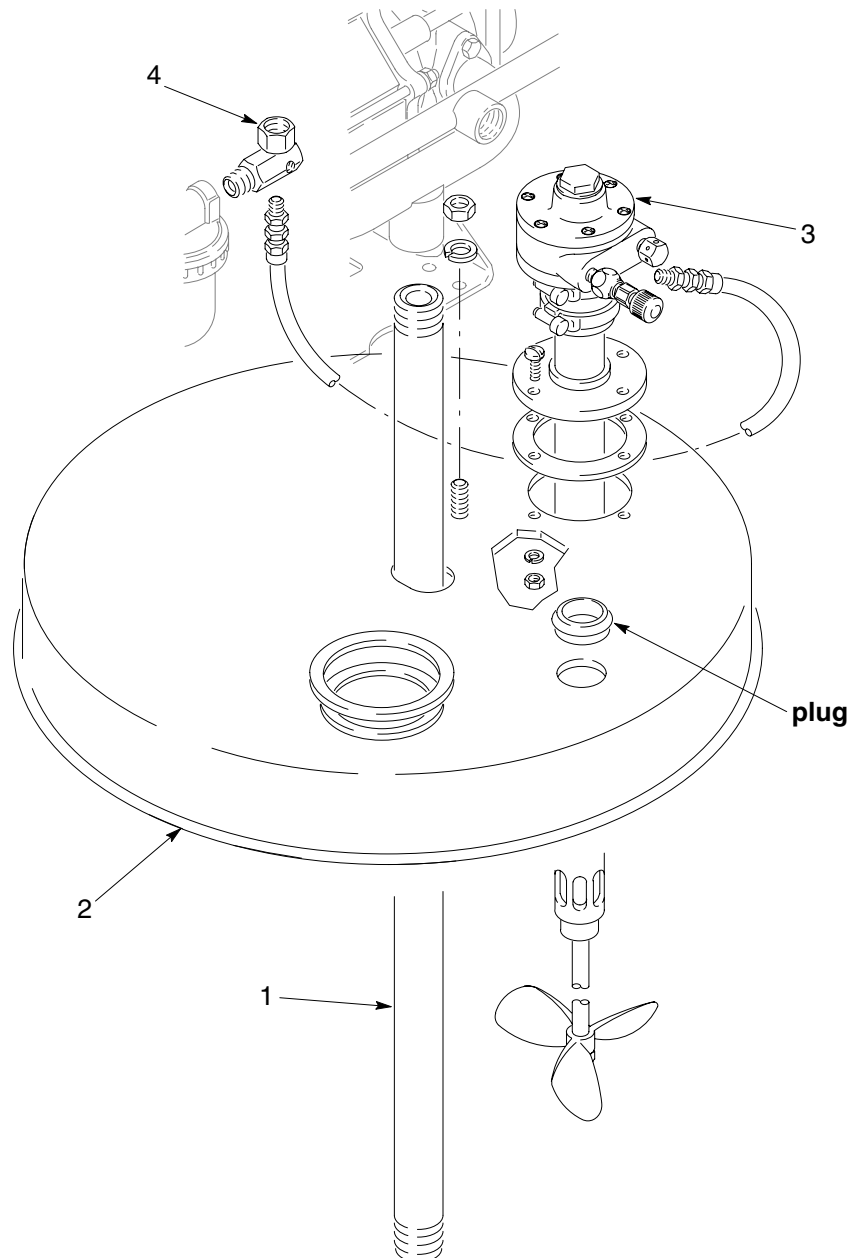

Return Tube Kit 223319

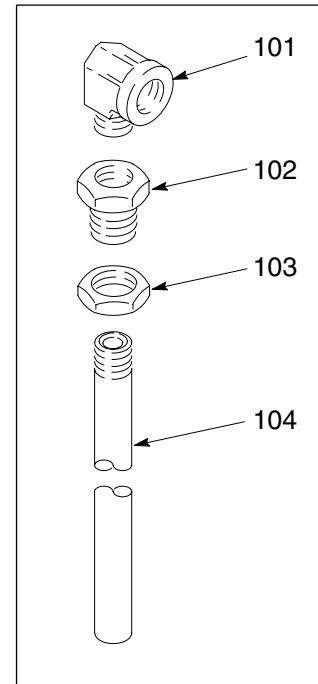

NOTE: When installing the Return Tube Kit, remove plug and install the adapter (102) and elbow (101). Install tube (104) and nut (103) from the bottom.

02337A

Suction Kit

Suction Kit 208259

55 gallon drum size Suction Kit 208259 (shown below) is available.

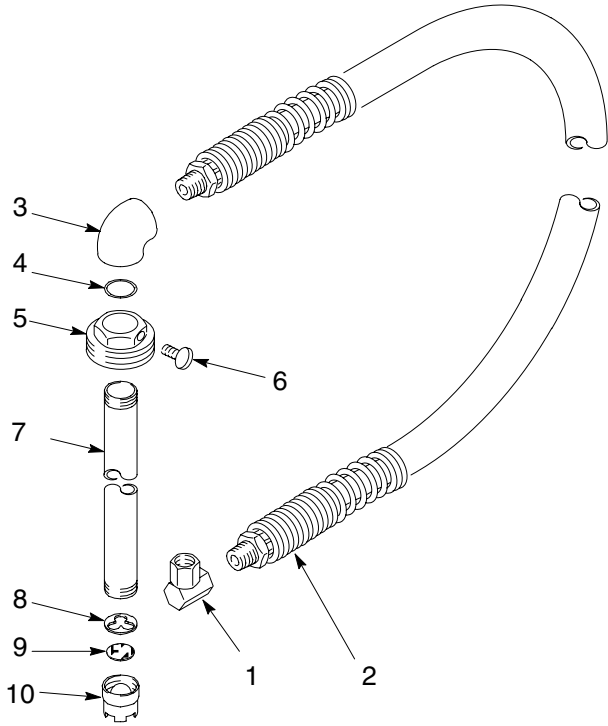

Ref. No.	Part No.	Description	Qty.
1	156589	UNION, 90° adapter, 3/4 nptf x 3/4 npsm	1
2	214961	HOSE, cpld, nylon, 3/4 in. ID, 6 ft (1.8 m) long, w/spring guard	1
3	156591	ELBOW, 90°	1
4	156593	O-RING, nitrile rubber	1
5	100220	THUMBSCREW	1
6	176684	ADAPTER, bung	1
7	156592	TUBE, riser	1
8	159100	RETAINER, screen	1
9	161377	SCREEN, filter	1
10	159101	NUT, screen retainer	1

Technical Data, 400 Series Pumps

Maximum working pressure	400 psi (2.8 MPa, 28 bar)
Maximum air input pressure	100 psi (0.7 MPa, 7 bar)
Air operating range	25 to 100 psi (0.07 to 0.7 MPa, 1.73 to 7 bar)
Maximum continuous pump speed	60 cpm
Fluid flow at 60 cpm	5.6 gpm (21.2 lpm)
Fluid volume per cycle	0.096 gal (0.366 liter)
Maximum suction lift (<i>water</i>)	15 ft (4.57 m)
Maximum operating temperature	150° F (65° C)
Air inlet	1/2 npt(f)
Fluid inlet	1.25 npt(f)
Fluid outlet	1 npt(f)
Weight	80.5 lb (36.2 kg)

Wetted Parts:

Model 220663 and 237008:

carbon steel, stainless steel, polypropylene, ultra high molecular weight polyethylene†, Nylon‡, PTFE

† Model 220663 only

‡ Model 237008 only

Model 220666 and 237011:

304 and 316 stainless steel, 17-4 PH stainless steel, polypropylene, ultra high molecular weight polyethylene†, Nylon‡, PTFE

† Model 220666 only

‡ Model 237011 only

Performance Chart, 400 Series Pumps

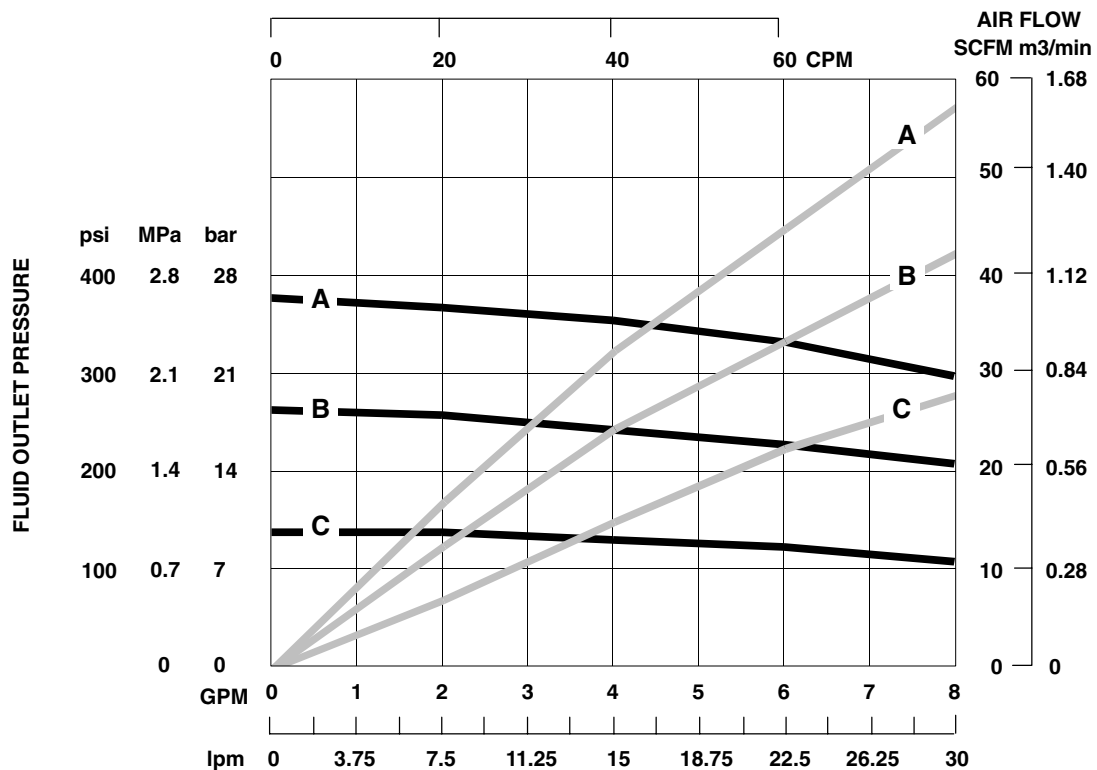

- KEY:** Fluid Outlet Pressure: black curves
Air Consumption: gray curves
A at 100 psi (0.7 MPa, 7 bar) air pressure
B at 70 psi (0.48 MPa, 4.9 bar) air pressure
C at 40 psi (0.28 MPa, 2.8 bar) air pressure

To find outlet pressure (psi/MPa/bar) at a specific delivery (GPM, lpm) and operating air pressure (psi/MPa/bar):

1. Locate desired delivery along bottom of chart.
2. Read vertical line up to intersection with selected fluid outlet pressure curve. Follow left to scale and read outlet pressure.

To find pump air consumption (CFM, m3/min) specific delivery (GPM, lpm) and operating air pressure (psi/MPa/bar):

1. Locate desired delivery along bottom of chart.
2. Read vertical line up to intersection with selected air consumption curve. Follow right to scale and read air consumption.

Technical Data, 1200 Series Pumps

Maximum working pressure 1200 psi
(8.3 MPa, 83 bar)

Maximum air input pressure 100 psi
(0.7 MPa, 7 bar)

Air operating range 25 to 100 psi
(0.07 to 0.7 MPa, 1.73 to 7 bar)

Maximum continuous pump speed 60 cpm

Fluid flow at 60 cpm 2 gpm (7.5 lpm)

Fluid volume per cycle 0.034 gal (0.128 liter)

Maximum suction lift (*water*) 15 ft (4.57 m)

Maximum operating temperature 150° F (65° C)

Air inlet 1/2 npt(f)

Fluid inlet 1.25 npt(f)

Fluid outlet 1 npt(f)

Weight 78 lb (35.1 kg)

Wetted Parts:

Model 220664 and 237009:

carbon steel, stainless steel, polypropylene, ultra high molecular weight polyethylene†, Nylon‡, PTFE

† Model 220664 only

‡ Model 237009 only

Model 220667 and 237012:

304 and 316 stainless steel, 17-4 PH stainless steel, polypropylene, ultra high molecular weight polyethylene†, Nylon‡, PTFE

† Model 220667 only

‡ Model 237012 only

Performance Chart, 1200 Series Pumps

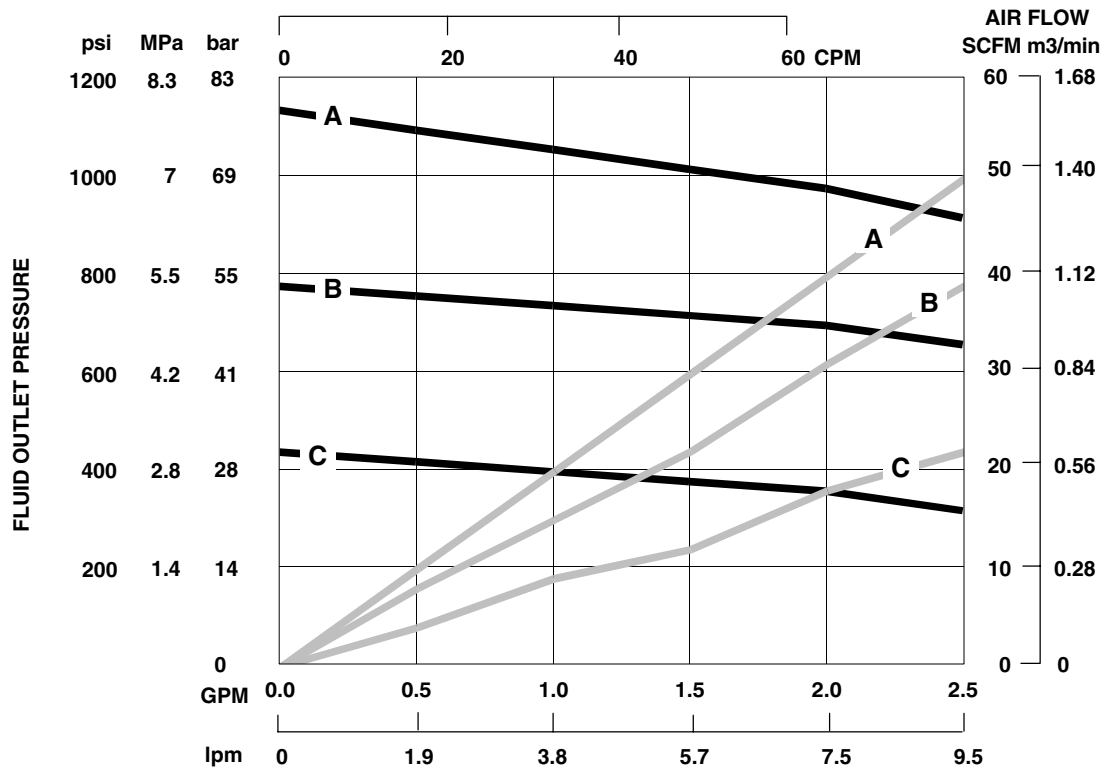

KEY: Fluid Outlet Pressure: black curves
Air Consumption: gray curves
A at 100 psi (0.7 MPa, 7 bar) air pressure
B at 70 psi (0.48 MPa, 4.9 bar) air pressure
C at 40 psi (0.28 MPa, 2.8 bar) air pressure

To find outlet pressure (psi/MPa/bar) at a specific delivery (GPM, lpm) and operating air pressure (psi/MPa/bar):

1. Locate desired delivery along bottom of chart.
2. Read vertical line up to intersection with selected fluid outlet pressure curve. Follow left to scale and read outlet pressure.

To find pump air consumption (CFM, m3/min) specific delivery (GPM, lpm) and operating air pressure (psi/MPa/bar):

1. Locate desired delivery along bottom of chart.
2. Read vertical line up to intersection with selected air consumption curve. Follow right to scale and read air consumption.

Technical Data, 2500 Series Pumps

Maximum working pressure 2500 psi
(17 MPa, 170 bar)

Maximum air input pressure 100 psi
(0.7 MPa, 7 bar)

Air operating range 25 to 100 psi
(0.07 to 0.7 MPa, 1.73 to 7 bar)

Maximum continuous pump speed 60 cpm

Fluid flow at 60 cpm 0.9 gpm (3.4 lpm)

Fluid volume per cycle 0.015 gal (0.058 liter)

Maximum suction lift (*water*) 6 ft (1.83 m)

Maximum operating temperature 150° F (65° C)

Air inlet 1/2 npt(f)

Fluid inlet 1.25 npt(f)

Fluid outlet 3/4 npt(f)

Weight 61 lb (27.5 kg)

Wetted Parts:

Model 220665 and 237010:

carbon steel, stainless steel, polypropylene, ultra high molecular weight polyethylene†, Nylon‡, PTFE

† Model 220665 only

‡ Model 237010 only

Model 220668 and 237013:

304 and 316 stainless steel, 17-4 PH stainless steel, polypropylene, ultra high molecular weight polyethylene†, Nylon‡, PTFE

† Model 220668 only

‡ Model 237013 only

Performance Chart, 2500 Series Pumps

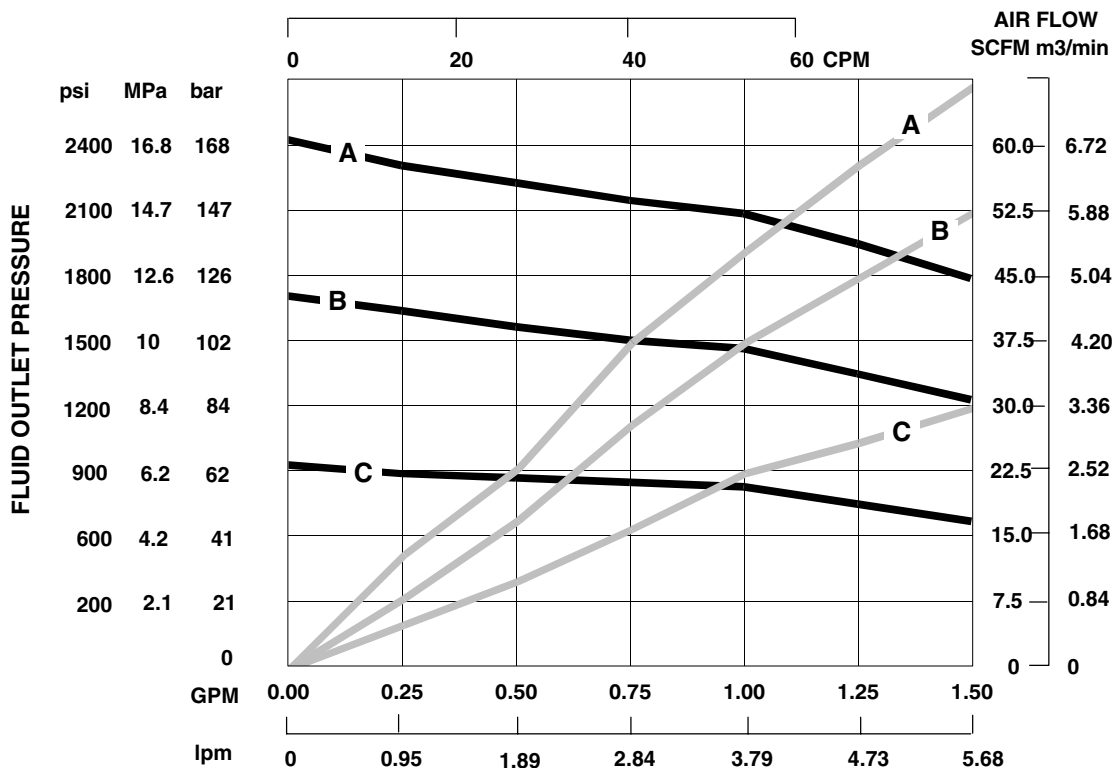

KEY: Fluid Outlet Pressure: black curves
Air Consumption: gray curves
A at 100 psi (0.7 MPa, 7 bar) air pressure
B at 70 psi (0.48 MPa, 4.9 bar) air pressure
C at 40 psi (0.28 MPa, 2.8 bar) air pressure

To find outlet pressure (psi/MPa/bar) at a specific delivery (GPM, lpm) and operating air pressure (psi/MPa/bar):

1. Locate desired delivery along bottom of chart.
2. Read vertical line up to intersection with selected fluid outlet pressure curve. Follow left to scale and read outlet pressure.

To find pump air consumption (CFM, m3/min) specific delivery (GPM, lpm) and operating air pressure (psi/MPa/bar):

1. Locate desired delivery along bottom of chart.
2. Read vertical line up to intersection with selected air consumption curve. Follow right to scale and read air consumption.

Dimensional Drawing

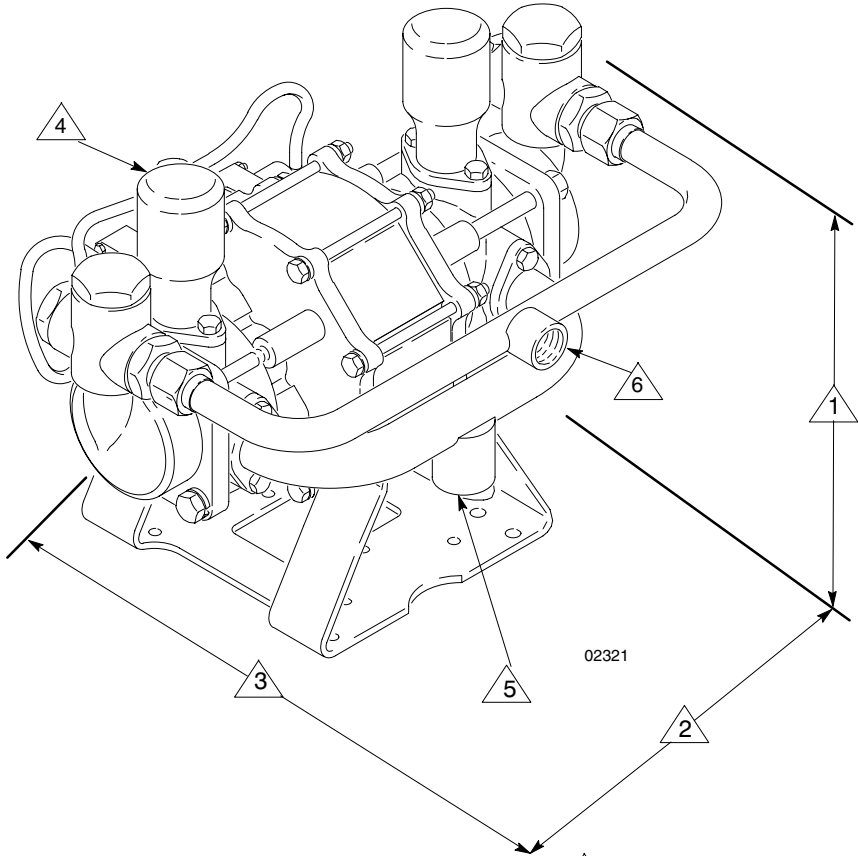

- 1** Height
400 and 1200 Series pumps: 15.1 in. (384 mm)
2500 Series pumps: 12.6 in. (320 mm)
- 2** Width: 19.6 in. (498 mm)
- 3** Depth: 15.83 in. (401 mm)
- 4** Air inlet: 1/2 npt(f)
- 5** Fluid inlet: 1.25 npt(f)
- 6** Fluid outlet: 400 and 1200 Series pumps: 1 npt(f)
2500 Series pumps: 3/4 npt(f)

Mounting Hole Layout

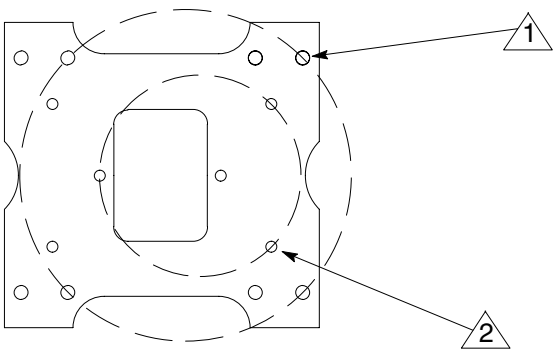

- 1** Four-hole bolt pattern on 10.5-in. (267mm) dia. circle
- 2** Three-hole bolt pattern on 6.38-in. (162mm) dia. circle

Graco Standard Warranty

Graco warrants all equipment manufactured by Graco and bearing its name to be free from defects in material and workmanship on the date of sale to the original purchaser for use. With the exception of any special, extended, or limited warranty published by Graco, Graco will, for a period of twelve months from the date of sale, repair or replace any part of the equipment determined by Graco to be defective. This warranty applies only when the equipment is installed, operated and maintained in accordance with Graco's written recommendations.

This warranty does not cover, and Graco shall not be liable for general wear and tear, or any malfunction, damage or wear caused by faulty installation, misapplication, abrasion, corrosion, inadequate or improper maintenance, negligence, accident, tampering, or substitution of non-Graco component parts. Nor shall Graco be liable for malfunction, damage or wear caused by the incompatibility of Graco equipment with structures, accessories, equipment or materials not supplied by Graco, or the improper design, manufacture, installation, operation or maintenance of structures, accessories, equipment or materials not supplied by Graco.

This warranty is conditioned upon the prepaid return of the equipment claimed to be defective to an authorized Graco distributor for verification of the claimed defect. If the claimed defect is verified, Graco will repair or replace free of charge any defective parts. The equipment will be returned to the original purchaser transportation prepaid. If inspection of the equipment does not disclose any defect in material or workmanship, repairs will be made at a reasonable charge, which charges may include the costs of parts, labor, and transportation.

THIS WARRANTY IS EXCLUSIVE, AND IS IN LIEU OF ANY OTHER WARRANTIES, EXPRESS OR IMPLIED, INCLUDING BUT NOT LIMITED TO WARRANTY OF MERCHANTABILITY OR WARRANTY OF FITNESS FOR A PARTICULAR PURPOSE.

Graco's sole obligation and buyer's sole remedy for any breach of warranty shall be as set forth above. The buyer agrees that no other remedy (including, but not limited to, incidental or consequential damages for lost profits, lost sales, injury to person or property, or any other incidental or consequential loss) shall be available. Any action for breach of warranty must be brought within two (2) years of the date of sale.

Graco makes no warranty, and disclaims all implied warranties of merchantability and fitness for a particular purpose in connection with accessories, equipment, materials or components sold but not manufactured by Graco. These items sold, but not manufactured by Graco (such as electric motors, switches, hose, etc.), are subject to the warranty, if any, of their manufacturer. Graco will provide purchaser with reasonable assistance in making any claim for breach of these warranties.

In no event will Graco be liable for indirect, incidental, special or consequential damages resulting from Graco supplying equipment hereunder, or the furnishing, performance, or use of any products or other goods sold hereto, whether due to a breach of contract, breach of warranty, the negligence of Graco, or otherwise.

FOR GRACO CANADA CUSTOMERS

The parties acknowledge that they have required that the present document, as well as all documents, notices and legal proceedings entered into, given or instituted pursuant hereto or relating directly or indirectly hereto, be drawn up in English. Les parties reconnaissent avoir convenu que la rédaction du présente document sera en Anglais, ainsi que tous documents, avis et procédures judiciaires exécutés, donnés ou intentés à la suite de ou en rapport, directement ou indirectement, avec les procédures concernées.

Graco Information

TO PLACE AN ORDER, contact your Graco distributor, or call one of the following numbers to identify the distributor closest to you:

1-800-328-0211 Toll Free

612-623-6921

612-378-3505 Fax

*All written and visual data contained in this document reflects the latest product information available at the time of publication.
Graco reserves the right to make changes at any time without notice.*

MM 307843

Graco Headquarters: Minneapolis
International Offices: Belgium, China, Japan, Korea

GRACO INC. P.O. BOX 1441 MINNEAPOLIS, MN 55440-1441

www.graco.com

PRINTED IN USA 307843 02/1988, Revised 08/2005